

harman/kardon

# AVR7300

7 x 110W 7.1 CHANNEL A/V RECEIVER

## SERVICE MANUAL



### CONTENTS

ESD WARNING.....	2	EXPLODED VIEW PARTS LIST.....	31
LEAKAGE TESTING.....	3	BLOCK DIAGRAM.....	33
BASIC SPECIFICATIONS.....	4	CIRCUIT DESCRIPTION.....	34
FEATURES.....	5	DC OFFSET/IDLE CURRENT ADJ.....	45
FRONT PANEL CONTROLS.....	6	BULLETIN HK2005-01.....	49
REAR PANEL CONNECTIONS.....	10	TECH TIP HKTT2003-01.....	50
REMOTE CONTROL FUNCTIONS.....	14	ELECTRICAL PARTS LIST.....	51
INSTALLATION/CONNECTIONS.....	18	SEMICONDUCTOR PINOUTS.....	70
OPERATION.....	21	PCB DRAWINGS.....	99
TROUBLESHOOTING GUIDE.....	29	SCHEMATICS.....	146
PROCESSOR RESET.....	29	WIRING DIAGRAM.....	157
UNIT EXPLODED VIEW.....	30	PACKAGING PARTS LIST.....	158

harman/kardon, Inc.  
250 Crossways Park Dr.  
Woodbury, New York 11797

Rev0 3/2005

---

## ELECTROSTATICALLY SENSITIVE (ES) DEVICES

Some semiconductor (solid state) devices can be damaged easily by static electricity. Such components commonly are called Electrostatically Sensitive (ES) Devices. Examples of typical ES devices are integrated circuits and some field effect transistors and semiconductor "chip" components.

The following techniques should be used to help reduce the incidence of component damage caused by static electricity.



1. Immediately before handling any semiconductor component or semiconductor-equipped assembly, drain off any electrostatic charge on your body by touching a known earth ground. Alternatively, obtain and wear a commercially available discharging wrist strap device, which should be removed for potential shock reasons prior to applying power to the unit under test.
2. After removing an electrical assembly equipped with ES devices, place the assembly on a conductive surface such as aluminum foil, to prevent electrostatic charge build-up or exposure of the assembly.
3. Use only a grounded-tip soldering iron to solder or unsolder ES devices.
4. Use only an anti-static solder removal device. Some solder removal devices not classified as "anti-static" can generate electrical charges sufficient to damage ES devices.
5. Do not use freon-propelled chemicals. These can generate electrical change sufficient to damage ES devices.
6. Do not remove a replacement ES device from its protective package until immediately before you are ready to install it. (Most replacement ES devices are packaged with leads electrically shorted together by conductive foam, aluminum foil or comparable conductive material.)
7. Immediately before removing the protective material from the leads of a replacement ES device, touch the protective material to the chassis or circuit assembly into which the device will be installed.

**CAUTION** : Be sure no power is applied to the chassis or circuit, and observe all other safety precautions.

8. Minimize bodily motions when handling unpackaged replacement ES devices. (Otherwise harmless motion such as the brushing together of your clothes fabric or the lifting of your foot from a carpeted floor can generate static electricity sufficient to damage an ES devices.

## PRODUCT SAFETY NOTICE

Each precaution in this manual should be followed during servicing.

Components identified with the IEC symbol  in the parts list are special significance to safety. When replacing a component identified with , use only the replacement parts designated, or parts with the same ratings or resistance, wattage, or voltage that are designated in the parts list in this manual. Leakage-current or resistance measurements must be made to determine that exposed parts are acceptably insulated from the supply circuit before returning the product to the customer.

## SAFETY PRECAUTIONS

The following check should be performed for the continued protection of the customer and service technician.

### LEAKAGE CURRENT CHECK

Measure leakage current to a known earth ground (water pipe, conduit, etc.) by connecting a leakage current tester between the earth ground and all exposed metal parts of the appliance (input/output terminals, screwheads, metal overlays, control shaft, etc.). Plug the AC line cord of the appliance directly into a 120V AC 60Hz outlet and turn the AC power switch on. Any current measured must not exceed 0.5mA.

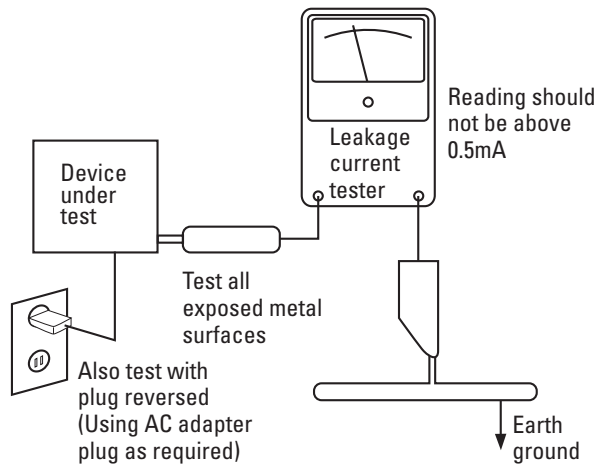

### AC Leakage Test

**ANY MEASUREMENTS NOT WITHIN THE LIMITS OUTLINED ABOVE ARE INDICATIVE OF A POTENTIAL SHOCK HAZARD AND MUST BE CORRECTED BEFORE RETURNING THE APPLIANCE TO THE CUSTOMER.**

## AVR 7300 TECHNICAL SPECIFICATIONS

**Audio Section**

Stereo Mode	
Continuous Average Power (FTC)	
125 Watts per channel, 20Hz–20kHz,	
@ <0.07% THD, both channels driven into 8 ohms	
Seven-Channel Surround Modes	
Power per Individual Channel	
Front L&R channels:	
110 Watts per channel	
@ <0.07% THD, 20Hz–20kHz into 8 ohms	
Center channel:	
110 Watts @ <0.07% THD, 20Hz–20kHz into 8 ohms	
Surround (L & R Side, L & R back) channels:	
110 Watts per channel	
@ <0.07% THD, 20Hz–20kHz into 8 ohms	
High Instantaneous Current	
Capability (HCC)	±75amps
Input Sensitivity/Impedance	
Linear (High-Level)	200mV/47k ohms
Signal-to-Noise Ratio (IHF-A)	100dB
Frequency Response	
@1W (+0dB/–3dB)	10Hz –100kHz
Surround System Adjacent Channel Separation	
Pro Logic I/II/Ix	40dB
Dolby Digital	55dB
DTS	55dB
Transient Intermodulation	
Distortion (TIM)	Unmeasurable
Slew Rate	40V/μSec

**FM Tuner Section**

Frequency Range	87.5–108.0MHz
Usable Sensitivity	IHF 1.3μV/13.2dB
Signal-to-Noise Ratio	Mono/Stereo 70/68dB
Distortion	Mono/Stereo 0.2/0.3%
Stereo Separation	40dB @ 1kHz
Selectivity	±400kHz, 70dB
Image Rejection	80dB
IF Rejection	90dB

**AM Tuner Section**

Frequency Range	520–1710kHz
Signal-to-Noise Ratio	45dB
Usable Sensitivity	Loop 500μV
Distortion	1kHz, 50% Mod 0.8%
Selectivity	±10kHz, 30dB

**Video Section**

Television Format	NTSC
Input Level/Impedance	1Vp-p/75 ohms
Output Level/Impedance	1Vp-p/75 ohms
Video Frequency Response (Composite and S-Video)	10Hz–8MHz (–3dB)
Video Frequency Response (Component Video)	10Hz–100MHz (–3dB)

**General**

Power Requirement	AC 120V/60Hz		
Power Consumption	Standby: 8.9W		
	Idle: 130W		
	Max: 1360W		
	(7 channels driven)		
Dimensions	Product	Shipping	
	Width	17.3" (440mm)	23" (583mm)
	Height	7.6" (192mm)	12.7" (323mm)
	Depth	20.5" (520mm)	24.7" (626mm)
Weight	55 lb (24.9kg)	69.3 lb (31.5kg)	

Depth measurement includes knobs, buttons and terminal connections.

Height measurement includes feet and chassis.

All features and specifications are subject to change without notice.

Harman Kardon, Power for the Digital Revolution and Logic 7 are registered trademarks of Harman International Industries, Incorporated.

|||||EzSet™ is a trademark of Harman International Industries, Incorporated (patent no. 5,386,478).

\*Trademarks of Dolby Laboratories.

DTS, DTS Surround, DTS-ES and DTS Neo:6 are registered trademarks of Digital Theater Systems, Inc.

VMAx is a registered trademark of Harman International Industries, Incorporated, and is an implementation of Cooper Bauck Transaural Stereo under patent license.

HDCD system manufactured under license from Pacific Microsonics, Inc. This product is covered by one or more of the following: in the USA: 5,479,168; 5,638,074; 5,640,161; 5,808,574; 5,838,274; 5,854,600; 5,864,311; 5,872,531; and in Australia: 669114. Other patents pending.

A-BUS and A-BUS Ready are registered trademarks of Leisure Tech Electronics Pty Ltd Australia.

TiVo is a registered trademark of TiVo, Inc.

Replay TV is a registered trademark of Digital Networks North America, Inc.

Faroudja, DCDi and DCDi by Faroudja are registered trademarks of Genesis Microchip, Inc.



<b>AVR7300 FEATURES</b>			
OUTPUT POWER(STEREO)	125W x 2	<b>OUTPUTS</b>	
OUTPUT POWER(SURROUND)	110W x 7	Pre-Outs	7.1
20Hz-20kHz, 8 Ohms, 0.07%THD	Yes	Tape	Rear
All Channels Driven	Yes	Video 1	Rear
High Current Capability	Yes	Video 2	Rear
All-Discrete Amplifier Circuitry	Yes	Audio/Video Outputs, Switchable	Front
Dual Power Supplies, Driver and Output Stages	Yes	Video Monitor	Rear
<b>AUDIO DSP SECTION</b>		Digital Outputs (Rear)	1 Coax, 1 Optical
Dolby Digital	Yes	Digital Outputs (Front)	1 Coax, 1 Optical
Dolby Pro Logic 2	Yes	<b>DIGITAL INPUTS</b>	
Dolby Digital Ex 6.1	Yes	Optical, Rear	3
Dolby Headphone	Yes	Coax, Rear	3
Dolby Virtualizer	Yes	Optical, Front	1
DTS, 5.1	Yes	Coax, Front	1
DTS, 6.1 Discrete	Yes	<b>GENERAL FEATURES</b>	
DTS NEO 6	Yes	On-Screen Display	Composite, S, Component
DTS 96/24	Yes	Input Titling	Yes
VMAx, 2 Modes Near & Far	Yes	FL Display	User ICON
Logic 7, Cinema & Music	5.1, 7.1	Remote In/Out	Yes
Logic 7, 5.1 & 7.1 Cinema & Music	Yes	RS 232	2 Way
HDCD Decoding	Yes	Port for Flash Upgrade	RS 232
MP 3 Decoding	Yes	A-Buss Ready	Yes, 2
5 Channel Stereo	Yes	IEC Detachable AC Cord	Yes
7 Channel Stereo	Yes	Speaker Binding Posts w/Banana Jack Compatibility	Yes
Hall 1	Yes	Thermal Controlled Air Cooling	
Hall 2	Yes	Smart Fan Control System	
Theater	Yes	Multiroom Audio	Yes
Quadruple X-Over System	Yes	Multiroom Video	Yes
DVD Audio Bass Management Capability	Yes	<b>REMOTE CONTROL</b>	
Sampling Upconversion to 96kHz	Yes	# of Devices	8
DSP Processor	CS49400	Preprogrammable	Yes
D/A Converters 192kHz/24 Bit	Yes	Learning	Yes
Flash Upgradeable	Yes	EZ Set	Yes
<b>VIDEO DSP SECTION</b>		LCD	Yes
S > Composite Downconversion	Yes	Backlit	Yes
Video Scaler/Enhancer	Faroujda 2300 Plugin		
Video Test Signals, Color Bars	Yes		
<b>AUDIO INPUTS</b>			
AM/FM	Yes		
CD	Yes		
Tape	Yes		
6 (5.1) Channel Direct	Yes		
8 (7.1) Channel Direct	Yes		
<b>AUDIO/VIDEO INPUTS</b>			
Video 1	Rear		
Video 2	Rear		
Video 3	Rear		
Video 4	Rear		
Video 5	Front		
DVD(Rear)	Yes		
S-VHS Video Inputs/Outputs	Yes		
Component Video Inputs/Outputs, HD TV Capable	3 In, 1 Out, 100Mhz		
Component Video Inputs, Configurable	Yes		

# FRONT-PANEL CONTROLS

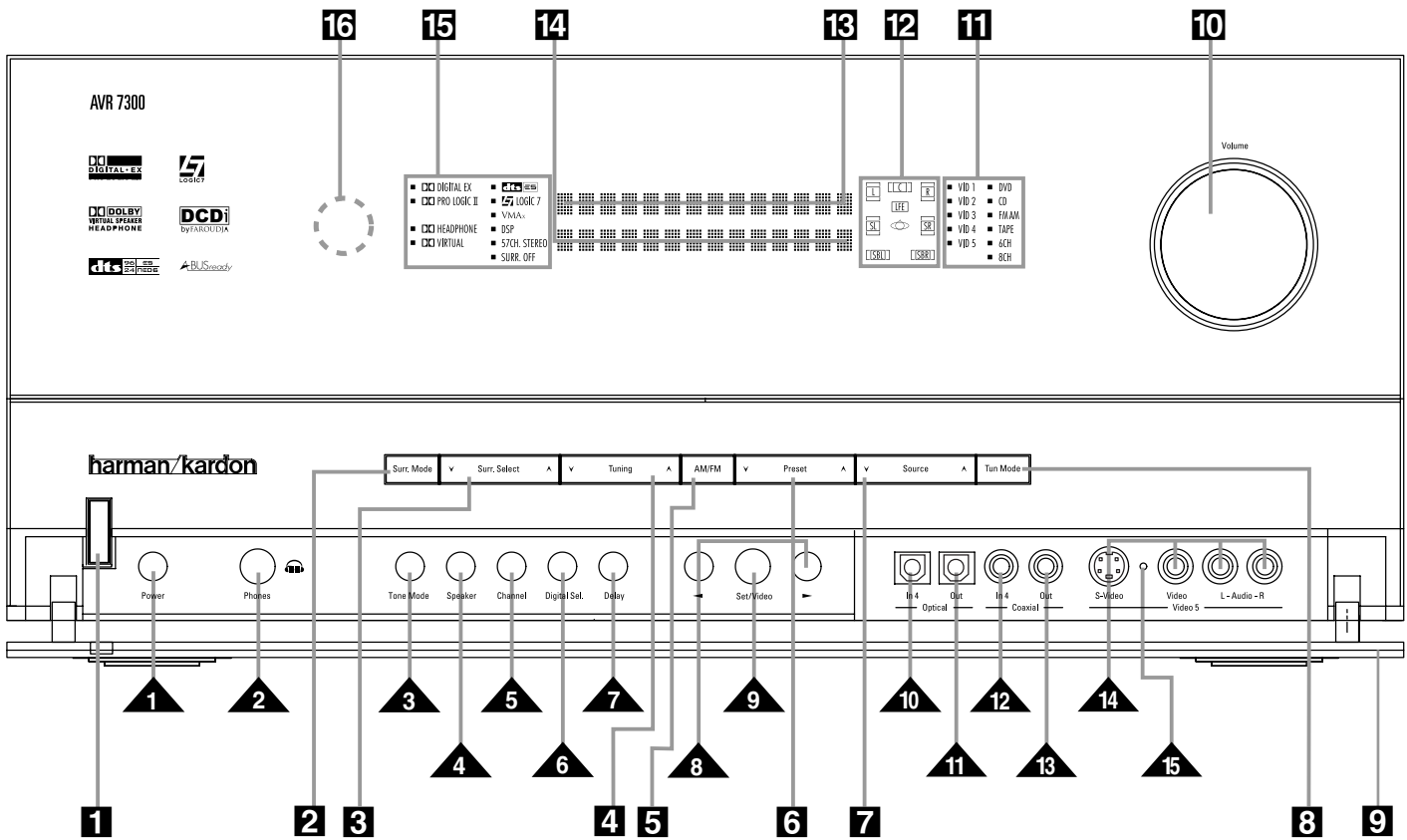

**NOTE:** To make it easier to follow the instructions that refer to this illustration, a larger copy may be downloaded from the Product Support section for this product at [www.harmankardon.com](http://www.harmankardon.com).

The following controls and indicators are available on the AVR 7300's front panel:

- |                                       |  |                                    |
|---------------------------------------|--|------------------------------------|
| <b>1</b> Standby/On Button            | <b>7</b> Input Source Selector             | <b>13</b> Upper Display Line       |
| <b>2</b> Surround Mode Group Selector | <b>8</b> Tuner Mode Selector               | <b>14</b> Lower Display Line       |
| <b>3</b> Surround Mode Selector       | <b>9</b> Front-Panel Control Door          | <b>15</b> Surround Mode Indicators |
| <b>4</b> Tuning Selector              | <b>10</b> Volume Control                   | <b>16</b> Remote Sensor Window     |
| <b>5</b> Tuner Band Selector          | <b>11</b> Input Indicators                 |                                    |
| <b>6</b> Preset Stations Selector     | <b>12</b> Speaker/Channel Input Indicators |                                    |

The following controls and jacks are located behind the **Front-Panel Control Door 9**. To open the door, gently press the left or right bottom-corner edge of the door in and gently swing the door down towards you.

- |                                  |                                   |                                     |
|----------------------------------|-----------------------------------|-------------------------------------|
| <b>1</b> Main Power Switch       | <b>6</b> Digital Input Selector   | <b>11</b> Optical Digital Output    |
| <b>2</b> Headphone Jack          | <b>7</b> Delay Adjust Selector    | <b>12</b> Coaxial 4 Digital Input   |
| <b>3</b> Tone Mode Button        | <b>8</b> ◀▶ Buttons               | <b>13</b> Coaxial Digital Output    |
| <b>4</b> Speaker Selector Button | <b>9</b> Set/Video Button         | <b>14</b> Video 5 Audio/Video Jacks |
| <b>5</b> Channel Adjust Selector | <b>10</b> Optical 4 Digital Input | <b>15</b> Input/Output Indicator    |

## FRONT - PANEL CONTROLS

**1 Standby/On Button:** When the Main Power Switch  is pressed in so that it is in the "ON" position, press this button to turn on the AVR 7300. When the unit is in the Standby mode, the switch is surrounded by amber lighting. When the unit is on, the lighting around the button is blue.

**2 Surround Mode Group Selector:** Press this button to select the top-level group of surround modes. Each press of the button will select one of the surround mode categories. Once the button is pressed so that the name of the desired surround mode category appears in the on-screen display and in the **Lower Display Line 14**, press the **Surround Mode Selector 3** to cycle through the individual modes available. For example, press this button to select Dolby modes, and then press the **Surround Mode Selector 3** to choose from the various mode options.

**3 Surround Mode Selector:** Press this button to select from among the available surround mode options for the surround mode category selected. The specific modes will vary based on the number of speakers available, the surround mode category and whether the input source is digital or analog. For example, press the **Surround Mode Group Selector 2** to select a category such as Dolby or Logic 7, and then press this button to see the specific mode choices that are available. For more information on mode selection, see page 35.

**4 Tuning Selector:** Press the left side of the button to tune lower-frequency stations and the right side of the button to tune higher-frequency stations. When the tuner is in the **MANUAL / MONO** mode, each tap of the selector will increase or decrease the frequency by one increment. When the tuner receives a strong-enough signal for adequate reception, **MANUAL TUNED** will appear in the **Lower Display Line 14** and in the on-screen display. When the tuner is in the **AUTO / STEREO** mode, press the button once, and the tuner will scan for a station with acceptable signal strength. When the next higher- or lower-frequency station with a strong-enough signal is tuned, the frequency scan will stop and the **Lower Display Line 14** and the on-screen display will indicate **AUTO TUNED**. When an FM Stereo station is tuned, the display will read **AUTO ST TUNED**. See page 39 for more information on using the tuner.

**5 Tuner Band Selector:** Pressing this button will switch to the Tuner mode. Pressing it again will switch between the AM and FM frequency bands. (See page 39 for more information on the tuner.)

**6 Preset Stations Selector:** Press this button to scroll up or down through the list of stations that have been entered into the preset memory. (See page 39 for more information on tuner programming.)

**7 Input Source Selector:** Press this button to change the input by scrolling up or down through the list of input sources.

**8 Tuner Mode Selector:** Press this button to select Auto or Manual tuning. When the button is pressed so that **AUTO / STEREO** appears in the **Upper Display Line 13**, the tuner will search for the next station with an acceptable signal when the **Tuning Selector 5 23 E** is pressed. When the button is pressed so that **MANUAL / MONO** appears in the **Upper Display Line 13**, each press of the **Tuning Selector 5 23 E** will increase the frequency. (See page 39 for more information on using the tuner.) This button may also be used to switch between Stereo and Mono modes for FM radio reception. When weak reception is encountered, select the **MANUAL / MONO** tuning mode. Press and hold again to switch back to **AUTO / STEREO** mode. (See page 39 for more information on using the tuner.)

**9 Front-Panel Control Door:** To open the door so that the front-panel jacks and controls behind this door may be accessed, gently push the door down and toward you, using either lower corner of the door.

**10 Volume Control:** Turn this knob clockwise to increase the volume, counterclockwise to decrease the volume. If the AVR 7300 is muted, adjusting the volume control will automatically release the unit from the silenced condition.

**11 Input Indicators:** One of these indicators will light to identify the currently selected input. Note that the entire list will light briefly each time the unit is turned on, as a test.

**12 Speaker/Channel Input Indicators:** These indicators are multipurpose, indicating both the speaker type selected for each channel and the number of audio channels available. The speaker indicators light as a single outline around the speaker position indica-

tor when a "small" speaker is selected and as a larger icon with three connected boxes when "large" speakers are selected. When only the speaker position letters appear, no speaker has been assigned to that position. (See page 26 for more information on configuring speakers.) The letters inside each box also indicate the active input channels. For standard analog inputs, only the L and R will light, indicating a stereo input. For a digital source, the indicators will light to display the channels being received at the digital input. When the letters flash, the digital input has been interrupted and an **UNLOCK** message may appear in the **Lower Display Line 14**. (See page 38 for more information on the Channel Indicators.)

**13 Upper Display Line:** Depending on the unit's status, a variety of messages will appear here. In normal operation, this line will show the current input source and identify whether an analog or digital input is in use. When the tuner is selected as the input, this line will identify the station as AM or FM and show the frequency and preset number, if any.

**14 Lower Display Line:** Depending on the unit's status, a variety of messages will appear here. In normal operation, the current surround mode will appear on this line.

**15 Surround Mode Indicators:** One of these indicators will light to show the surround mode in use. Depending on the specific combination of input sources and surround mode selected, more than one indicator may light. (See page 35 for more information.)

**16 Remote Sensor Window:** The sensor behind this window receives infrared signals from the remote control. Aim the remote at this area and do not block or cover it unless an external remote sensor is installed.

## FRONT-PANEL CONTROLS

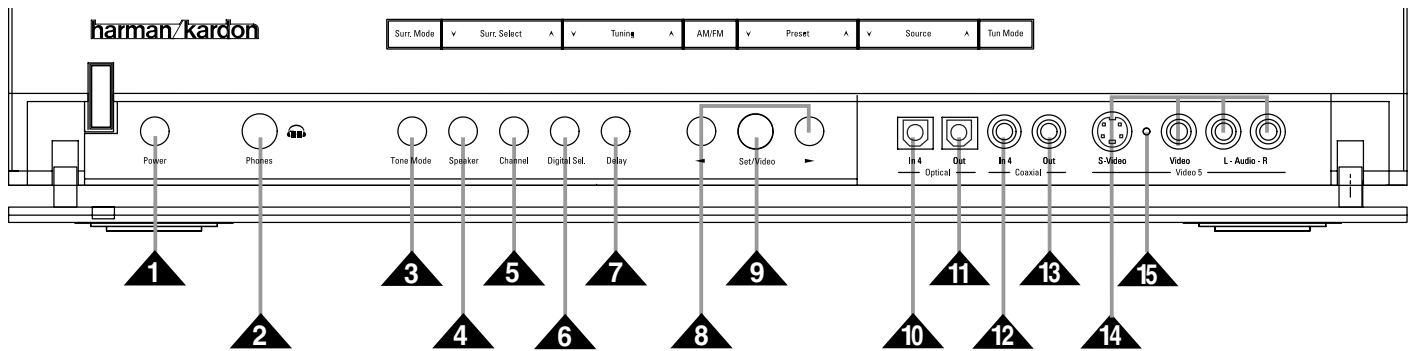

**NOTE:** To make it easier to follow the instructions that refer to this illustration, a larger copy may be downloaded from the Product Support section for this product at [www.harmankardon.com](http://www.harmankardon.com).

The following controls and jacks are located behind the front-panel door. To open the door, place the edge of a finger on the left or right bottom edge of the panel and gently swing the door down toward you.

- |                             |                              |                                |
|-----------------------------|------------------------------|--------------------------------|
| ▲ 1 Main Power Switch       | ▲ 6 Digital Input Selector   | ▲ 11 Optical Digital Output    |
| ▲ 2 Headphone Jack          | ▲ 7 Delay Adjust Selector    | ▲ 12 Coaxial 4 Digital Input   |
| ▲ 3 Tone Mode Button        | ▲ 8 ◀▶ Buttons               | ▲ 13 Coaxial Digital Output    |
| ▲ 4 Speaker Selector Button | ▲ 9 Set/Video Button         | ▲ 14 Video 5 Audio/Video Jacks |
| ▲ 5 Channel Adjust Selector | ▲ 10 Optical 4 Digital Input | ▲ 15 Input/Output Indicator    |

▲ **1 Main Power Switch:** Press this switch to apply power to the AVR 7300. When the switch is pressed in, the unit is placed in a Standby mode, as indicated by the lighting around the **Standby/On Button 1** turning amber. The switch **MUST** be pressed in to operate the unit. To turn the unit off and prevent the use of the remote control, this switch should be pressed until it pops out from the front panel so that the word "OFF" may be read at the top of the switch.

**NOTE:** This switch is normally left in the "ON" position.

▲ **2 Headphone Jack:** This jack may be used to listen to the AVR 7300's output through a pair of headphones. Be certain that the headphones have a standard 1/4" stereo phone plug, or that you use an adapter, as needed, to convert the plug on your headphones to the 1/4" jack used on the AVR. When the headphone jack is in use, the main room speakers will automatically be turned off and the unit will output a

standard stereo signal. You may also use one of the Dolby Headphone modes for an enhanced listening experience. For more information on headphone listening, see page 35.

▲ **3 Tone Mode Button:** This button controls the tone mode settings, enabling adjustment of the bass and treble boost/cut. You may also use it to take the tone controls out of the signal path completely for "flat" response. The first press of the button displays a **TONE MODE** message in the **Lower Display Line 14** and in the on-screen display. To take the controls out of the signal path, press either of the **◀▶ Buttons 8** until the display reads **TONE OUT**. To change the bass or treble settings, press the button again until the desired option appears in the **Lower Display Line 14** and in the on-screen display and then press either of the **◀▶ Buttons 8** to enter the desired boost or cut setting. See page 35 for more information on the tone controls.

▲ **4 Speaker Selector Button:** Press this button to begin the process of configuring the AVR 7300 for the type of speakers it is being used with. For complete information on configuring the speaker settings, see page 26.

▲ **5 Channel Adjust Selector:** Press the button to begin the process of adjusting the channel level outputs using the source currently playing through your AVR. For complete information on adjusting the channel output level, see page 40.

▲ **6 Digital Input Selector:** Press this button to begin the process of selecting a digital source for use with the currently selected input. Once the button has been pressed, use the **◀▶ Buttons 8** to choose the desired input and then press the **Set/Video Button 9** to enter the setting into the unit's memory. See page 35 for more information on digital audio.

## FRONT - PANEL CONTROLS

**7 Delay Adjust Selector:** Press this button to begin the process of adjusting the delay settings. See page 28 for more information on delay adjustments.

**8 ◀▶ Buttons:** When making system configuration changes using the front-panel controls, press these buttons to scroll through the available choices for the option being adjusted.

**9 Set/Video Button:** This button has two functions. Press it to turn the video processing circuits on or off, as indicated by **F A R O U D J A : O N** or **F A R O U D J A : O F F** messages in the **Lower Display Line 14** and semi-OSD display. (See page 31 for more information on the video processing circuits.) The button is also used when making many of the configuration and setup adjustments from the front panel. When selecting a specific item to adjust, or after selecting a configuration setting with the **◀▶ Buttons 8**, press this button to enter the setting information to the unit's memory.

**10 Optical 4 Digital Input:** Connect the optical digital output of an audio or video product to this jack.

**11 Optical Digital Output:** Connect this jack to the optical digital audio input of a compatible digital recorder.

**12 Coaxial 4 Digital Input:** Connect the coaxial digital output of a digital audio product such as a portable audio player or video game to this jack.

**13 Coaxial Digital Output:** Connect this jack to the digital audio input of a compatible digital recorder.

**14 Video 5 Input/Output Jacks:** These audio/video jacks may be used as either inputs or outputs for temporary connection to video games or portable audio/video products such as camcorders and portable audio players. (See page 40 for more information on switching these jacks between an input and output.)

**15 Input/Output Status Indicator:** This LED indicator will normally light green to show that the front-panel **Video 5 Input/Output Jacks 14** is operating as an input. When this jack is configured for use as an output, the appropriate indicator will turn red to show that the jack may be used as an output for recording. (See page 23 for more information on configuring the front-panel jacks as outputs, rather than inputs.)

# REAR-PANEL AUDIO CONNECTIONS

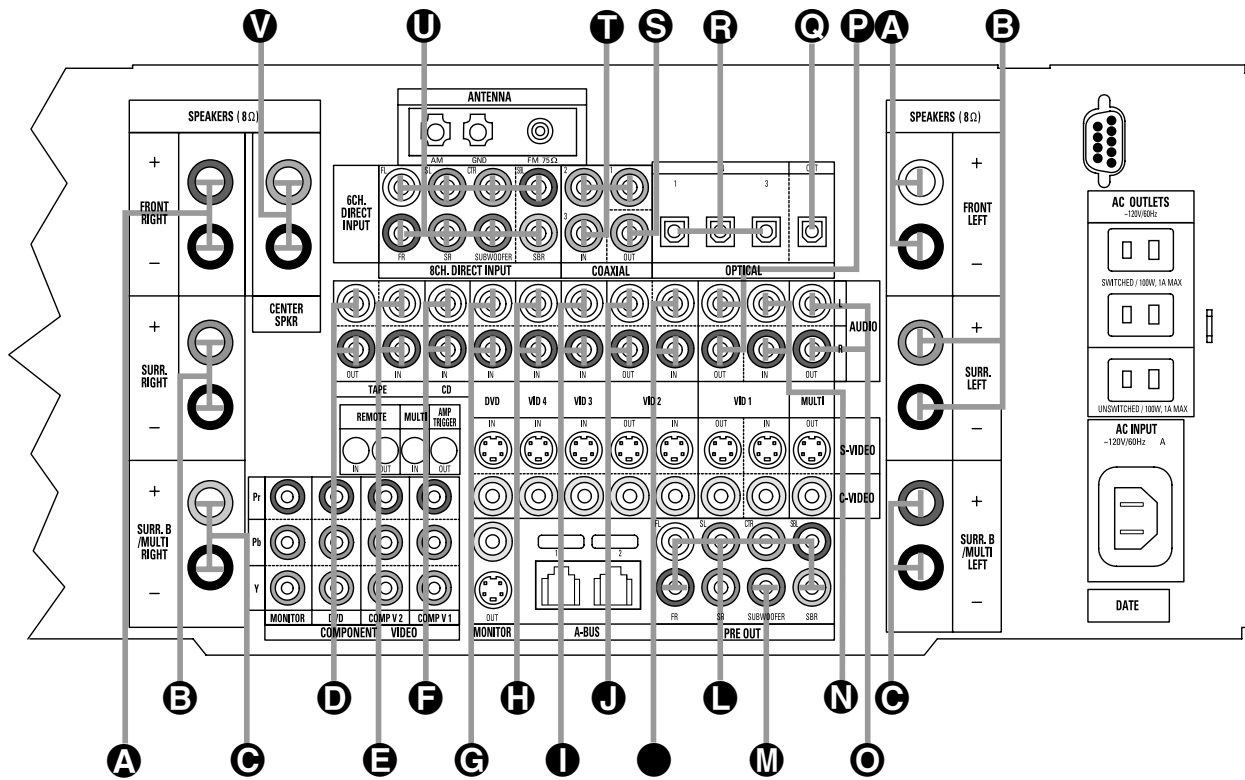

**NOTE:** To make it easier to follow the instructions that refer to this illustration, a larger copy may be downloaded from the Product Support section for this product at [www.harmankardon.com](http://www.harmankardon.com).

- |  |                                  |  |
|--|----------------------------------|--|
| <b>A</b> Front Speaker Outputs                   | <b>I</b> Video 3 Audio Inputs    | <b>Q</b> Optical Digital Audio Output  |
| <b>B</b> Surround Speaker Outputs                | <b>J</b> Video 2 Audio Outputs   | <b>R</b> Optical Digital Audio Inputs  |
| <b>C</b> Surround Back/Multiroom Speaker Outputs | <b>K</b> Video 2 Audio Inputs    | <b>S</b> Coaxial Digital Audio Output  |
| <b>D</b> Tape Outputs                            | <b>L</b> Preamp Outputs          | <b>T</b> Coaxial Digital Audio Inputs  |
| <b>E</b> Tape Inputs                             | <b>M</b> Subwoofer Output        | <b>U</b> 8-Channel Direct Audio Inputs |
| <b>F</b> CD Inputs                               | <b>N</b> Video 1 Audio Inputs    | <b>V</b> Center Speaker Output         |
| <b>G</b> DVD Audio Inputs                        | <b>O</b> Multiroom Audio Outputs |  |
| <b>H</b> Video 4 Audio Inputs                    | <b>P</b> Video 1 Audio Outputs   |  |

**NOTE:** To assist in making the correct connections for multichannel input, output and speaker connections, all connection jacks and terminals are color-coded in conformance with the CEA standards as follows:

Front Left:	White	Subwoofer:	Purple
Front Right:	Red	Digital Audio:	Orange
Center:	Green	Composite Video:	Yellow
Surround Left:	Blue	Component Video "Y":	Green
Surround Right:	Gray	Component Video "Pr":	Red
Surround Back Left:	Brown	Component Video "Pb":	Blue
Surround Back Right:	Tan		

# REAR-PANEL AUDIO CONNECTIONS

**A Front Speaker Outputs:** Connect these outputs to the matching + or – terminals on your left and right speakers. When making speaker connections, always make certain to maintain correct polarity by connecting the color-coded (white for front left and red for front right) (+) terminals on the AVR 7300 to the red (+) terminals on the speakers and the black (–) terminals on the AVR 7300 to the black (–) terminals on the speakers. See page 18 for more information on speaker polarity.

**B Surround Speaker Outputs:** Connect these outputs to the matching + and – terminals on your surround channel speakers. In conformance with the CEA color-code specification, the blue terminal is the positive (+) terminal that should be connected to the red (+) terminal on the Surround Left speaker with older color-coding, while the gray terminal should be connected to the red (+) terminal on the Surround Right speaker with the older color-coding. Connect the black (–) terminal on the AVR to the matching black negative (–) terminals for each surround speaker. (See page 18 for more information on speaker polarity.)

**C Surround Back/Multiroom Speaker Outputs:** These speaker terminals are normally used to power the surround back left/surround back right speakers in a 7.1-channel system. However, they may also be used to power the speakers in a second zone, which will receive the output selected for a multiroom system. To change the output fed to these terminals from the default of the Surround Back speakers to the Multiroom Output, you must change a setting in the **MULTI-ROOM SETUP** menu of the OSD system. See page 44 for more information on configuring this speaker output. In normal surround system use, the brown and black terminals are the surround back left channel positive (+) and negative (–) connections and the tan and black terminals are the surround back right positive (+) and negative (–) terminals. For multiroom use, connect the brown and black SBL terminals to the red and black connections on the left remote zone speaker and connect the tan and black SBR terminals to the red and black terminals on the right remote zone speaker.

**D Tape Outputs:** Connect these jacks to the Record/Input jacks of an audio recorder.

**E Tape Inputs:** Connect these jacks to the Play/Out jacks of an audio recorder.

**F CD Audio Inputs:** Connect these jacks to the left/right analog audio output of a compact disc player or CD changer or other audio source.

**G DVD Audio Inputs:** Connect the left/right analog audio jacks of a DVD player or other video source to these jacks. When digital audio and/or component video outputs are used with a DVD player and the AVR 7300, the default connection points are the **Coaxial 1 Digital Audio Input**

**I** and the **DVD Component Video Inputs F**. If other

jacks are used to connect a DVD player, the AVR may be reconfigured to accommodate the hookup by using the **IN/OUT SETUP** menu as shown on page 23.

**H Video 4 Audio Inputs:** Connect the left/right analog audio outputs of a video device to these jacks. The AVR 7300's remote control has a satellite receiver as the default for this input, but you may connect any video source such as a VCR, HDTV receiver, personal video recorder, or other device to these inputs. Note that if the source device offers either digital audio or component video capability, those connections must be made separately, and the AVR 7300 configured accordingly. (See page 23 for more information on configuring an input for various source options.)

**I Video 3 Audio Inputs:** Connect the left/right analog audio outputs of a video device to these jacks. The AVR 7300's remote control has a cable set-top as the default for this input, but you may connect any video source such as a VCR, HDTV or satellite receiver, personal video recorder, or other device to these inputs. Note that if the source device offers either digital audio or component video capability, those connections must be made separately, and the AVR 7300 configured accordingly. (See page 23 for more information on configuring an input for various source options.)

**J Video 2 Audio Outputs:** Connect the left/right analog audio RECORD/IN jacks of a video recording device such as a VCR, DVD-recorder or personal video recorder to these jacks.

**K Video 2 Audio Inputs:** Connect the left/right analog audio PLAY/OUT jacks of a video recording device such as a VCR, DVD-recorder or personal video recorder to these jacks. The AVR 7300's remote control has a "TV" as the default for this input, but you may connect any video source such as a VCR, HDTV or cable set-top box, personal video recorder, or other device to these inputs. Note that if the source device offers either digital audio or component video capability, those connections must be made separately, and the AVR 7300 configured accordingly. (See page 23 for more information on configuring an input for various source options.)

**L Preamp Outputs:** Connect these jacks to an optional, external power amplifier for applications where higher power is desired.

**M Subwoofer Output:** Connect this jack to the line-level input of a powered subwoofer. If an external subwoofer amplifier is used, connect this jack to the subwoofer amplifier input.

**N Video 1 Audio Inputs:** Connect the left/right analog audio **PLAY/OUT** jacks of a video recording device such as a VCR, DVD-recorder or personal video recorder to these jacks.

**O Multiroom Audio Outputs:** Connect these jacks to the optional external audio power amplifier that delivers the source selected for multizone distribution.

**P Video 1 Audio Outputs:** Connect the left/right analog audio RECORD/IN jacks of a video recording device such as a VCR, DVD-recorder or personal video recorder to these jacks. The AVR 7300's remote control has a VCR as the default for this input, but you may connect any video source such as a VCR, HDTV or cable set-top box, personal video recorder, or other device to these inputs. Note that if the source device offers either digital audio or component video capability, those connections must be made separately, and the AVR 7300 configured accordingly. (See page 23 for more information on configuring an input for various source options.)

**Q Optical Digital Audio Output:** Connect this jack to the optical digital input connector on a CD-R/RW, MiniDisc or other compatible digital recorder.

**R Optical Digital Audio Inputs:** Connect the optical digital output from a DVD player, HDTV receiver, the S/P-DIF output of a compatible computer sound card playing MP3 files or streams, LD player or CD player to these jacks. The signal may be a Dolby Digital signal, a DTS signal or a standard PCM digital source.

**S Coaxial Digital Audio Output:** Connect this jack to the coaxial digital input of a CD-R/RW, MiniDisc or other compatible digital recorder.

**T Coaxial Digital Audio Inputs:** Connect the coaxial digital output from a DVD player, HDTV receiver, the S/P-DIF output of a compatible computer sound card playing MP3 files or streams, LD player or CD player to these jacks. The signal may be a Dolby Digital signal, DTS signal or a standard PCM digital source. Do not connect the RF digital output of an LD player to these jacks.

**U 8-Channel Direct Inputs:** These jacks are used for connection to source devices such as DVD-Audio or SACD players with discrete analog outputs. Depending on the source device in use, all eight jacks may be used, though in many cases only connections to the front left/right, center, surround left/right and LFE (subwoofer input) jacks will be used for standard 5.1 audio signals.

**V Center Speaker Outputs:** Connect these outputs to the matching + and – terminals on your center channel speaker. In conformance with the CEA color-code specification, the green terminal is the positive (+) terminal that should be connected to the red (+) terminal on speakers with the older color-coding. Connect the black (–) terminal on the AVR to the black negative (–) terminal on your speaker. (See page 18 for more information on speaker polarity.)

# VIDEO AND SYSTEM CONNECTIONS

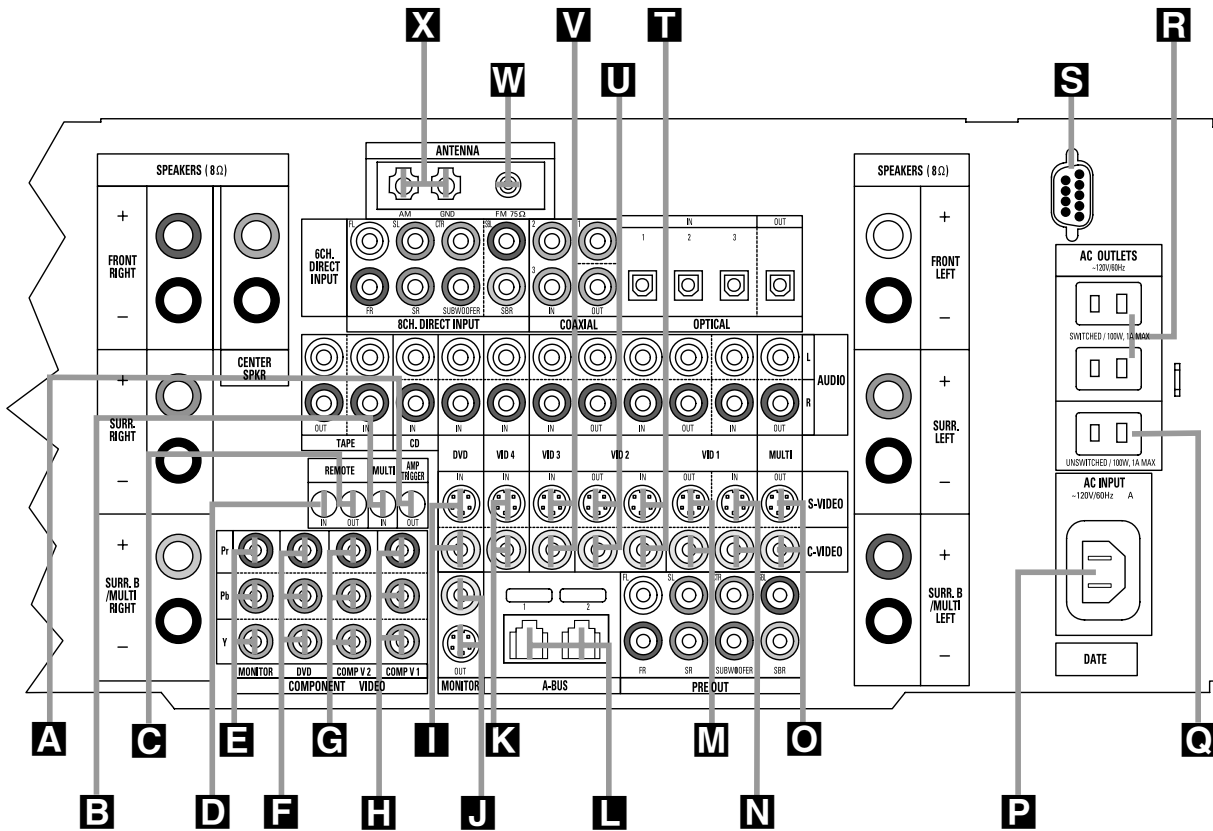

**NOTE:** To make it easier to follow the instructions that refer to this illustration, a larger copy may be downloaded from the Product Support section for this product at [www.harmankardon.com](http://www.harmankardon.com).

- |  |                                  |                                |
|--|----------------------------------|--------------------------------|
| <b>A</b> Amp Trigger                     | <b>I</b> DVD Video Inputs        | <b>Q</b> Unswitched AC Outlet  |
| <b>B</b> Multiroom IR Input              | <b>J</b> Video Monitor Outputs   | <b>R</b> Switched AC Outlets   |
| <b>C</b> Remote IR Output                | <b>K</b> Video 4 Video Inputs    | <b>S</b> RS-232 Port           |
| <b>D</b> Remote IR Input                 | <b>L</b> A-BUS Connectors        | <b>T</b> Video 2 Video Inputs  |
| <b>E</b> Component Video Monitor Outputs | <b>M</b> Video 1 Video Outputs   | <b>U</b> Video 2 Video Outputs |
| <b>F</b> DVD Component Video Inputs      | <b>N</b> Video 1 Video Inputs    | <b>V</b> Video 3 Video Inputs  |
| <b>G</b> Component Video 2 Inputs        | <b>O</b> Multiroom Video Outputs | <b>W</b> FM Antenna Jack       |
| <b>H</b> Component Video 1 Inputs        | <b>P</b> AC Power Cord Jack      | <b>X</b> AM Antenna Terminals  |

<p><b>NOTE:</b> To assist in making the correct connections for multichannel input, output and speaker connections, all connection jacks and terminals are color-coded in conformance with the CEA standards as follows:</p>	Front Left:	White	Subwoofer:	Purple
	Front Right:	Red	Digital Audio:	Orange
	Center:	Green	Composite Video:	Yellow
	Surround Left:	Blue	Component Video "Y":	Green
	Surround Right:	Gray	Component Video "Pr":	Red
	Surround Back Left:	Brown	Component Video "Pb":	Blue
	Surround Back Right:	Tan		



# VIDEO AND SYSTEM CONNECTIONS

**A Amp Trigger:** Connect this jack to the "Trigger In" jack of an optional, external power amplifier that is equipped for remote turn-on via a 6-volt signal. When this connection is used, the AVR 7300 will automatically send a low-voltage signal that turns on the amp when the AVR is on, and since the signal is not present when the AVR is turned off, the amplifier will also turn off with the AVR 7300.

**B Multiroom IR Input:** Connect the output of an IR sensor in a remote room to this jack to operate the AVR's multiroom control system.

**C Remote IR Output:** This connection permits the IR sensor in the receiver to serve other remote-controlled devices. Connect this jack to the "IR IN" jack on Harman Kardon (or other compatible) equipment.

**D Remote IR Input:** If the AVR 7300's front-panel IR sensor is blocked due to cabinet doors or other obstructions, an external IR sensor may be used. Connect the output of the sensor to this jack.

**E Component Video Monitor Outputs:** Connect these outputs to the component video inputs of a video projector or monitor. When a source connected to one of the **Component Video Inputs FGH** is selected, the signal will be sent to these jacks.

**F DVD Component Video Inputs:** Connect the component video outputs of a DVD player or any other video source equipped with Y/Pr/Pb or RGB component video outputs to these jacks. The factory default is for these jacks to be linked to the **DVD Audio Inputs G** and the **Coaxial 1 Digital Audio Input I**, but you may change the setting at any time through the **IN / OUT SETUP** menu. See page 23 for more information on configuring the component video inputs.

**G Component Video 2 Inputs:** These inputs may be used with any video source device equipped with analog Y/Pr/Pb or RGB component video outputs. The factory default is for these jacks to be linked to the Video 2 through Video 4 inputs, but you may change the setting at any time through the **IN / OUT SETUP** menu. See page 23 for more information on configuring the component video inputs.

**H Component Video 1 Inputs:** These inputs may be used with any video source device equipped with analog Y/Pr/Pb or RGB component video outputs. The factory default is for these jacks to be linked to the Video 1 input, but you may change the setting at any time through the **IN / OUT SETUP** menu. See page 23 for more information on configuring the component video inputs.

**I DVD Video Inputs:** The default use for these inputs is the connection to the composite and/or S-Video output of a DVD player, but they may be used with a different video source if desired.

**J Video Monitor Outputs:** When using an analog video display that has only standard composite and S-Video inputs, connect the output of these jacks (depending on which types of video are used by your source devices) to the matching inputs on your television or video display. When using a "digital ready" or HDTV display that is compatible with 480P or higher inputs, you do not need to make these connections as all incoming video will be up-scaled to 480P and sent through the **Component Video Monitor Jacks E** with the OSD messages.

**K Video 4 Video Inputs:** Connect the composite or S-Video jacks of a video device to these jacks. The AVR 7300's remote control has a satellite receiver as the default for this input, but you may connect any video source such as a VCR, HDTV receiver, personal video recorder, or other device to these inputs. (See page 23 for more information on configuring an input for various source options.)

**L A-BUS Connectors:** Connect these jacks to an optional A-BUS®-certified remote modules to extend the multiroom capabilities of your AVR 7300. See page 20 for more information on A-BUS.

**M Video 1 Video Outputs:** Connect the composite S-Video RECORD/IN jacks of a video recording device such as a VCR, DVD-Recorder or personal video recorder to these jacks.

**N Video 1 Video Inputs:** Connect the composite or S-Video PLAY/OUT jacks of a video recording device such as a VCR, DVD-recorder or personal video recorder to these jacks. The AVR 7300's remote control has a VCR as the default for this input, but you may connect any video source such as a VCR, HDTV or cable set-top box, personal video recorder, or other device to these inputs. (See page 23 for more information on configuring an input for various source options.)

**O Multiroom Video Outputs:** Connect these jacks to the cabling and/or an optional, external video distribution amplifier that delivers the video source selected for the multizone distribution to the remote rooms.

**P AC Power Cord Jack:** Connect the AC power cord to this jack when the installation is complete. To ensure safe operation, use only the power cord supplied with the unit. If a replacement is required, it must be of the same type and capacity.

**Q Unswitched AC Outlet:** This outlet may be used to power any AC device as long as its power consumption does not exceed 100 watts. The power

will remain available at this outlet as long as the AVR 7300 is plugged into an AC power source, regardless of whether the AVR itself is on or off.

**R Switched AC Outlets:** These outlets may be used to power AC devices that you wish to have turn on and off when the AVR is turned on or off. The total power consumption of all devices connected to the two outlets may not exceed 100 watts.

**S RS-232 Port:** This jack may be used to control the AVR 7300 over a bi-directional RS-232 serial control link to a compatible computer or programmable remote control system. Due to the complexity of programming RS-232 commands, we strongly recommend that connections to this port for control purposes be made by a trained and qualified technician. This jack may also link to a compatible computer to upgrade the software and operating system of the AVR 7300 when appropriate upgrades are available.

**T Video 2 Video Inputs:** Connect the composite or S-Video PLAY/OUT jacks of a video recording device such as a VCR, DVD-recorder or personal video recorder to these jacks. The AVR 7300's remote control has a VCR as the default for this input, but you may connect any video source such as a VCR, HDTV or cable set-top box, personal video recorder, or other device to these inputs. (See page 23 for more information on configuring an input for various source options.)

**U Video 2 Video Outputs:** Connect the composite or S-Video RECORD/IN jacks of a video recording device such as a VCR, DVD-recorder or personal video recorder to these jacks.

**V Video 3 Video Inputs:** Connect the composite or S-Video jacks of a video device to these jacks. The AVR 7300's remote control has a satellite receiver as the default for this input, but you may connect any video source such as a VCR, HDTV receiver, personal video recorder, or other device to these inputs. (See page 23 for more information on configuring an input for various source options.)

**W FM Antenna:** Connect the supplied indoor or an optional external FM antenna to this terminal.

**X AM Antenna:** Connect the AM loop antenna supplied with the receiver to these terminals. If an external AM antenna is used, make connections to the **AM** and **GND** terminals in accordance with the instructions supplied with the antenna.

# MAIN REMOTE CONTROL FUNCTIONS

- 1 Power Off Button
- 2 Power On Button
- 3 LCD Information Display
- 4 Input Selectors
- 5 AVR Selector
- 6 DSP Surround Mode Selector
- 7 Test Button
- 8 Video Processing On/Off Button
- 9 Direct Button
- 10 Clear Button
- 11 Numeric Keys
- 12 Tuning Mode Button
- 13 Dim Button
- 14 Channel Select Button
- 15 Navigation Button
- 16 Digital Select Button
- 17 Set Button
- 18 Volume Up/Down Buttons
- 19 Transport Fast-Play/Scan Buttons
- 20 Main Transport Controls
- 21 Track Skip Up/Down Buttons
- 22 Preset Up/Down Button
- 23 Tuning Up/Down Button
- 24 Disc Skip Button
- 25 Program Button
- 26 Light Button
- 27 Multiroom Button
- 28 Macro Buttons
- 29 Sleep Button
- 30 Night Mode Button
- 31 OSD Button
- 32 Tone Control Button
- 33 Mute Button
- 34 AM/FM Button
- 35 Channel Up/Down Selector
- 36 Transport Play Buttons
- 37 Delay Select Button
- 38 Speaker Select Button
- 39 Memory Button
- 40 Stereo Mode Select Button
- 41 DTS Neo:6 Mode Select Button
- 42 Logic 7 Mode Select Button
- 43 DTS Digital Mode Select Button
- 44 Dolby Mode Select Button
- 45 6/8-Channel Input Select
- 46 SPL Select Button
- 47 EzSet Microphone Sensor
- 48 Lens

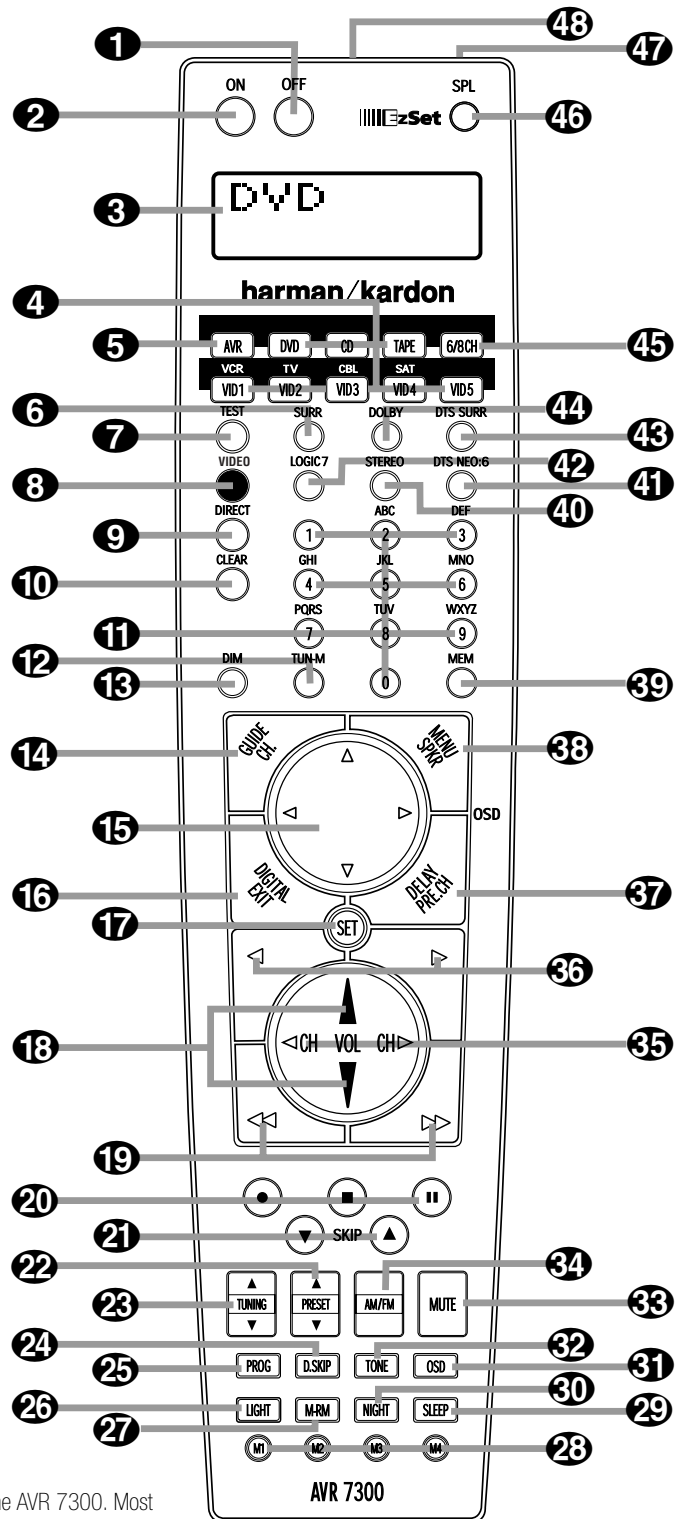

**NOTES:**

- The function names shown here are each button's feature when used with the AVR 7300. Most buttons have additional functions when used with other devices. When a button is pressed, the function name will appear in the bottom line of the LCD Information Display 3.
- The jack on the upper right side of the remote is reserved for future use. Do not remove the plug provided or connect any device to the jack.
- To make it easier to follow the instructions that refer to this illustration, a larger copy may be downloaded from the Product Support section for this product at [www.harmankardon.com](http://www.harmankardon.com).

# MAIN REMOTE CONTROL FUNCTIONS

**IMPORTANT NOTE:** The AVR 7300's remote may be programmed to control up to nine devices, including the AVR 7300. Before using the remote, it is important to remember to press the **Input Selector Button 4** that corresponds to the unit you wish to operate. In addition, the AVR 7300's remote is shipped from the factory to operate the AVR 7300 and most Harman Kardon CD or DVD players and cassette decks. The remote is also capable of operating a wide variety of other products using the control codes that are part of the remote. Before using the remote with other products, follow the instructions on pages 46 – 55 to program the proper codes for the products in your system.

It is also important to remember that many of the buttons on the remote take on different functions, depending on the product selected using the **Input Selectors 4**. The descriptions shown here primarily detail the functions of the remote when it is used to operate the AVR 7300.

- 1 Power Off Button:** Press this button to place the AVR 7300 or a selected device in the Standby mode. Note that this will turn off the main room functions, but if the Multiroom system is activated, it will continue to function.
- 2 Power On Button:** Press this button to turn on the power to a device selected by first pressing one of the **Input Selectors 4**.
- 3 LCD Information Display:** This two-line screen displays various information depending on the commands that have been entered into the remote.
- 4 Input Selectors:** Pressing one of these buttons will perform three actions at the same time. First, if the AVR 7300 is not turned on, this will power up the unit. Next, it will select the source shown on the button as the input to the AVR 7300. Finally, it will change the remote control so that it controls the device selected. After pressing one of these buttons, you must press the **AVR Selector Button 5** again to operate the AVR 7300's functions with the remote.
- 5 AVR Selector:** Pressing this button will switch the remote so that it will operate the AVR 7300's functions. If the AVR 7300 is in the Standby mode, it will also turn the AVR 7300 on.
- 6 DSP Surround Mode Selector:** Press this button to select one of the DSP surround modes, such as VMAx, Hall 1, Hall 2 or Theater. Each press of the button selects another mode. (See page 36 for more information on surround modes.)

**7 Test Button:** Press this button to begin the sequence used to calibrate the AVR 7300's output levels. (See page 29 for more information on calibrating the AVR 7300.)

**8 Video Processing On/Off Button:** Press this button to turn the video processing circuits on or off. See page 31 for more information.

**9 Direct Button:** Press this button when the tuner is in use to start the sequence for direct entry of a station's frequency. After pressing the button, simply press the proper **Numeric Keys 11** to select a station. (See page 39 for more information on the tuner.)

**10 Clear Button:** When programming the remote or using the EzSet feature, press this button to cancel the current function. When using the remote to enter frequencies for direct tuner access, press this button to clear previous entries.

**11 Numeric Keys:** These buttons serve as a 10-button numeric keypad to enter tuner preset positions. They are also used to select channel numbers when TV, Cable or SAT has been selected on the remote, or to select track numbers on a CD, DVD or LD player, depending on how the remote has been programmed. These buttons are also used to enter letters and numbers when renaming devices in the LCD Information Display. (See page 53 for more information on renaming devices and keys.)

**12 Tuning Mode Button:** Press this button to change the tuner mode between manual and automatic. When the button is pressed so that **AUTO / STEREO** appears in the **Upper Display Line 13** and in the on-screen display, only stations with acceptable signal quality will be tuned, and the tuner will play FM stations in stereo, when available. In the **AUTO** mode, when the **Tuning Up/Down Buttons 4 23 E** are pressed, the unit will automatically search for the next available station with good signal strength. When this button is pressed so that **MANUAL / MONO** appears in the **Upper Display Line 13** and in the on-screen display, each press of the **Tuning Up/Down Buttons 4 23 E** will move the frequency up or down in single-step increments. When the FM band is in use, pressing the button so that the **MANUAL** mode is activated will enable you to tune stations with weak signals by changing to monaural reception. (See page 39 for more information on tuner operation.)

**13 Dim Button:** This button activates the Dimmer function, which reduces the brightness of the front-panel display, or turns it off entirely. Press the button once to reduce the display brightness by 50%, and press it again within five seconds and the main display will go completely dark. Note that this setting is temporary; regardless of any changes, the display will always return to full brightness when the AVR is turned on. The blue accent lighting inside the **Volume Control 10** and the **Input/Output Indicator 15** will go out when the panel lights are at half brightness or fully dimmed.

**14 Channel Select Button:** This button is used to start the process of setting the AVR 7300's output levels to an external source. Once this button is pressed, press the **▲/▼** on the **Navigation Button 15** to select the channel being adjusted, then press the **Set Button 17**, followed by the **▲/▼** on the **Navigation Button 15** again, to change the level setting. (See page 40 for more information.)

**15 Navigation Button:** This single disc-like button is used to navigate through the on-screen configuration menus, to scroll through the options list and to select choices for the various settings such as delay, speakers, surround modes, digital inputs, etc. To use the button, simply press it left, right, up or down in the direction indicated by the **▲/▼/◀/▶** icons printed on the button disc. Depending on the menu being used, pressing the button will either change a specific menu or configuration choice or change the option shown in the on-screen or front-panel display. The sections in this manual describing the unit's individual features and configuration options contain specific information on how the navigation controls are used.

**16 Digital Select Button:** Press this button to assign one of the digital inputs **F T 10 12** to a source. (See page 37 for more information on using digital inputs.)

**17 Set Button:** This button is used to enter settings into the AVR 7300's memory. It is also used in the setup procedures for delay time, speaker configuration and channel output level adjustment.

**18 Volume Up/Down Buttons:** These controls share the disc in the lower portion of the remote with the **Channel Up/Down Selector 35**. To raise the volume, press the button marked **▲** by pressing towards the top of the remote. To lower the volume, press the button marked **▼** by pressing towards the bottom of the remote. The **◀▶** buttons on the left and right sides of this disc change channels up or down when the TV, cable box or satellite **Input Selectors 4** have been pressed.

# MAIN REMOTE CONTROL FUNCTIONS

**19 Transport Fast-Play/Scan Buttons:** These buttons have no direct function on the AVR 7300, but they are used when the remote is programmed for a compatible DVD, CD or tape player. Pressing these buttons will transmit a fast-play forward, fast-play reverse, or fast-forward or fast-reverse scan command, according to the capabilities of the player being controlled. In the factory default setting, these buttons are preprogrammed with the remote codes for Harman Kardon DVD players so that you may control a compatible player even when the remote is directly controlling the AVR, a TV set, or a cable or satellite set-top box.

**20 Main Transport Controls:** These buttons have no direct function on the AVR 7300 but are used when the remote is programmed for a compatible DVD, CD or tape player. Pressing these buttons will transmit a stop (■), record (●), or pause (⏸) command, according to the capabilities of the player being controlled. In the factory default setting, these buttons are programmed with the remote codes for Harman Kardon DVD players so that you may control a compatible player even when the remote is directly controlling the AVR, a TV set, or a cable or satellite set-top box.

**21 Track Skip Up/Down Buttons:** These buttons do not have a direct function with the AVR 7300, but when used with a compatibly programmed CD or DVD changer will change the track or chapter currently being played. In the factory default setting, these buttons are programmed with the remote codes for Harman Kardon DVD players so that you may control a compatible player even when the remote is directly controlling the AVR, a TV set, or a cable or satellite set-top box.

**22 Preset Up/Down Button:** When the tuner is in use, press this button to scroll through the stations programmed into the AVR 7300's memory.

**23 Tuning Up/Down Button:** Press this button when the tuner is in use to change the station to one with a higher or lower frequency. When the tuner is in the **MANUAL / MONO** mode, each tap of the selector will increase or decrease the frequency by one increment. When the tuner receives a strong-enough signal for adequate reception, **MANUAL TUNED** will appear in the **Lower Display Line 14** and in the on-screen display. When the tuner is in the **AUTO / STEREO** mode, press the button

once, and the tuner will scan for a station with acceptable signal strength. When the next higher- or lower-frequency station with a strong-enough signal is tuned, the frequency scan will stop and the **Lower Display Line 14** and the on-screen display will indicate **AUTO TUNED**. When an FM Stereo station is tuned, the display will read **AUTO ST TUNED**. See page 35 for more information on using the tuner.

**24 Disc Skip Button:** This button has no direct function for the AVR 7300 but may be used to change the disc in a CD or DVD changer when the remote is programmed for that type of device.

**25 Program Button:** This button is used to begin the process of programming the remote. Press and hold this button for three seconds to place the remote in the programming mode. Once the red LED under the **Set Button 17** lights, release the button. You may then select from the desired option. (See pages 46 – 55 for more information on configuring the remote.)

**26 Light Button:** Press this button to activate the remote's backlight for ease of use in darkened rooms.

**27 Multiroom Button:** Press this button to begin the process of activating the multiroom system or to change the input or volume level for the second zone. (See page 44 for more information on the multiroom system.)

**28 Macro Buttons:** Press these buttons to store or recall a "Macro", which is a preprogrammed sequence of commands stored in the remote. (See page 49 for more information on macros.)

**29 Sleep Button:** Press this button to place the unit in the Sleep mode. After the time shown in the display, the AVR 7300 will automatically go into the Standby mode. Each press of the button changes the time until turn-off in the following order:

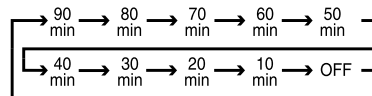

When the Sleep timer is in use, the front-panel displays and other indicators will dim to half-brightness.

**30 Night Mode Button:** Press this button to activate the Night mode. This mode is available in specially encoded Dolby Digital sources, and it preserves dialogue (center channel) intelligibility at low volume levels.

**31 OSD Button:** Press this button to activate or turn off the On-Screen Display (OSD) system used to set up or adjust the AVR 7300's parameters.

**32 Tone Control Button:** This button controls the tone mode settings, enabling adjustment of the bass and treble boost/cut. You may also use it to take the tone controls out of the signal path completely for "flat" response. The first press of the button displays a **TONE IN** message in the **Lower Display Line 14** and in the on-screen display. To take the controls out of the signal path, press either of the **▲/▼ Navigation Buttons 15** until the display reads **TONE OUT**. To change the bass or treble settings, press the button again until the desired option appears in the **Lower Display Line 14** and on-screen display and then press either of the **▲/▼ Navigation Buttons 15** to enter the desired boost or cut setting. See page 35 for more information on the tone controls.

**33 Mute Button:** Press this button to momentarily silence the AVR 7300 or TV set being controlled, depending on which device has been selected.

**34 AM/FM Button:** Press this button to select the AVR 7300's tuner as the listening choice. Pressing this button when the tuner is already in use will select between the AM and FM bands.

**35 Channel Up/Down Selector:** These selectors share the disc in the lower portion of the remote with the **Volume Up/Down Buttons 18**. They have no function when the AVR is being controlled, but when programmed for use with a VCR, TV, cable box, satellite receiver or other similar product, they will change the channel up or down. See pages 46 – 55 for more information on programming the remote.

**36 Transport Play Buttons:** These buttons have no direct function on the AVR 7300, but they are used when the remote is programmed for a compatible DVD, CD or tape player. Pressing these buttons will transmit a forward- or reverse-play command, according to the capabilities of the player being controlled. In the factory default setting, these buttons are programmed for Harman Kardon DVD players so that you may control a compatible player even when the remote is directly controlling the AVR, a TV set or a cable or satellite set-top box.

## MAIN REMOTE CONTROL FUNCTIONS

**37 Delay Select Button:** This button selects adjustments to the A/V Sync Delay and the individual channel delays. The first press of the button displays an **A / V SYNC DELAY** message in the **Lower Display Line 14** and in the on-screen display, which means that you may change the amount of time that all channels are delayed together behind the video. This enables you to compensate for the loss of lip sync that may be caused by digital video processing in your display or by television stations. To change the A/V Sync Delay, press the **Set Button 17** while the **A / V SYNC DELAY** message is visible and then use the **▲/▼ Navigation Button 15** to change the setting so that the sound and the video image are in sync. To change the delay for an individual output channel, press the **▲/▼ Navigation Button 15** until the desired channel name is shown, and then press the **Set Button 17**. Use the **▲/▼ Navigation Buttons 15** to change the delay amount. (See page 28 for more information on delay options.)

**38 Speaker Select Button:** Press this button to begin the process of configuring the AVR 7300's bass management system. Then press the **▲/▼ Navigation Button 15** to select the channel you wish to set up. Press the **Set Button 17** and then select another channel to configure. When all adjustments have been completed, press the **Set Button 17** twice to exit the settings and return to normal operation. (See page 26 for more information on speaker setup.)

**39 Memory Button:** Press this button to enter a radio station to the AVR 7300's preset memory. First, tune the desired station, and then press this button. Within five seconds of when you see the station's frequency flash in the **Upper Display Line 13** and in the on-screen display, press the numeric keys for the preset number between 01 and 30 that you wish to assign to the station. (See page 39 for more information.)

**40 Stereo Mode Select Button:** Press this button to select a stereo listening mode. When the button is pressed so that **SURROUND OFF** appears in the **Lower Display Line 14**, the AVR will operate in a bypass mode with true, fully analog, two-channel

left/right stereo mode with no surround processing or bass management, as opposed to other modes where digital processing is used. When the button is pressed so that **SURROUND OFF** appears in the **Lower Display Line 14**, and the **DSP** and **SURROUND OFF Surround Mode Indicators 15** are lit, you will enjoy a two-channel presentation of the sound along with the benefits of bass management. Depending on whether your system is configured for 5.1 or 6.1/7.1 channels, the next press of the button will cause either **5 CH STEREO** or **7 CH STEREO** to appear, and the stereo signal will be routed to all five (or seven) speakers. (See page 36 for more information on stereo playback modes.)

**41 DTS Neo:6 Mode Select Button:** Press this button as needed to select one of the DTS Neo:6 modes. (See page 36 for the available DTS Neo:6 options.)

**42 Logic 7 Mode Select Button:** Press this button to select from among the available Logic 7 surround modes. (See page 36 for the available Logic 7 options.)

**43 DTS Digital Mode Select Button:** When a DTS-encoded digital source is playing, each press of this button will scroll through the available DTS modes. The specific choice of modes will vary according to the type of encoding on the disc and your system's speaker configuration. When a DTS source is not in use, this button has no function. (See page 36 for the available DTS digital options.)

**44 Dolby Mode Select Button:** This button is used to select from the available Dolby Surround modes. Each press of this button will select one of the Dolby Pro Logic II or Dolby Pro Logic Ix modes. When a Dolby Digital-encoded source is in use, Dolby Digital or Dolby Digital EX mode may also be selected. (See page 36 for the available Dolby surround mode options.)

**45 6/8-Channel Input Select:** Press this button to select the device connected to the **8-Channel Direct Inputs 1**. (See page 34 for more information.)

**46 SPL Select Button:** This button activates the EzSet function to quickly and accurately calibrate the AVR 7300's output levels. When the button is

pressed, you will then need to select between automatic EzSet operation or using the remote as a manual SPL meter by pressing the **▲/▼ Navigation Button 15** until your choice appears in the remote's LCD display. Press the **Set Button 17** to enter the setting, and then follow the instructions as displayed in the LCD display. (For complete information, see page 29.)

**47 EzSet Microphone Sensor:** The microphone sensor that is used by the EzSet system is behind the three slots at the top of the remote control. When using EzSet to calibrate the AVR 7300, be certain that the slots are not covered. (See page 29 for more information on using EzSet.)

**48 Lens:** The infrared emitters behind the plastic lens at the top of the remote communicate the remote codes to the AVR 7300. Be certain that the lens is not covered when using the remote, and point the lens toward the AVR for best results. In learning mode, the remote receives IR codes to be learned through a sensor behind the lens.

**NOTE:** DO NOT remove the rubber plug that is supplied to cover the jack on the upper right side of the remote. The jack is not active and is reserved for future use.

# INSTALLATION AND CONNECTIONS

## System Installation

After unpacking the unit, locating it in a place with adequate ventilation and placing it on a solid surface capable of supporting its weight, you will need to make the connections to your audio and video equipment.

**IMPORTANT NOTE:** For your personal safety and to avoid possible damage to your equipment and speakers, it is always a good practice to turn off and unplug the AVR and ALL source equipment from the AC output before making any audio or video system connections.

### Audio Equipment Connections

We recommend that you use high-quality interconnect cables when making connections to source equipment and recorders to preserve the integrity of the signals.

1. Connect the analog output of a CD player to the **CD Inputs** **F**.

**NOTE:** If your CD player has both fixed and variable audio outputs, it is best to use the fixed output unless you find that the input to the receiver is so low that the sound is noisy, or so high that it is distorted.

2. Connect the analog Play/Out jacks of a cassette deck, MD, CD-R or other audio recorder to the **Tape Inputs** **E**. Connect the analog Record/In jacks on the recorder to the **Tape Outputs** **D** on the AVR 7300.
3. Connect the output of any digital audio source such as a CD or DVD changer or player, advanced video game, a digital satellite receiver, HDTV tuner or digital cable set-top box or the output of a compatible computer sound card to the **Optical and Coaxial Digital Audio Inputs** **R T 10** **12**.
4. Connect the coaxial or optical **Digital Audio Outputs** **Q S 11 13** of the AVR 7300 to the matching digital input connections on a CD-R or MiniDisc recorder.
5. Assemble the AM loop antenna supplied with the unit so that the tabs at the bottom of the antenna loop snap into the holes in the base. Connect it to the **AM and GND Screw Terminals** **X**.

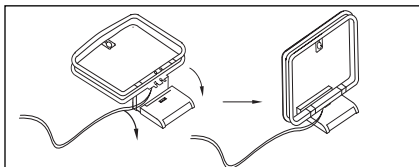

6. Connect the supplied FM antenna to the **FM (75-Ohm) Connection** **W**. The FM antenna may be an external roof antenna, an inside powered or wire-lead antenna or a connection from a cable TV system. If the antenna or connection uses

300-ohm twin-lead cable, you must use an optional 300-ohm-to-75-ohm adapter to make the connection.

7. Connect the front, center, surround and surround back speaker outputs **A B C V** to the respective speakers.

To ensure that all the audio signals are carried to your speakers without loss of clarity or resolution, we suggest that you use high-quality speaker cable. Many brands of cable are available and the choice of cable may be influenced by the distance between your speakers and the receiver, the type of speakers you use, personal preferences and other factors. Your dealer or installer is a valuable resource to consult in selecting the proper cable.

Regardless of the brand of cable selected, we recommend that you use cable with a gauge of 14 or smaller. Remember that in specifying cable, the lower the number, the thicker the cable.

Cable with a gauge of 16 may be used for short runs of less than 10 feet. We do not recommend that you use cables with an AWG equivalent of 18 or higher, due to the power loss and degradation in performance that will occur.

Cables that are run inside walls should have the appropriate markings to indicate listing with UL, CSA or other appropriate testing agency standards. Questions about running cables inside walls should be referred to your installer or a licensed electrician who is familiar with the NEC and/or the applicable building codes in your area.

When connecting wires to the speakers, be certain to observe proper polarity. Note that the positive (+) terminal of each speaker connection now carries a specific color code, as noted on page 9. However, most speakers still use a red terminal for the positive connection. Connect the "negative" or "black" wire to the same terminal on both the receiver and the speaker.

**NOTE:** While most speaker manufacturers adhere to an industry convention of using black terminals for negative and red ones for positive, some may vary from this configuration. To ensure proper phase and optimal performance, consult the identification plate on your speaker or the speaker's manual to verify polarity. If you do not know the polarity of your speaker, ask your dealer for advice before proceeding, or consult the speaker's manufacturer.

We also recommend that the length of cable used to connect speaker pairs be identical. For example, use the same length piece of cable to connect the front-left and front-right or surround-left and sur-

round-right speakers, even if the speakers are a different distance from the AVR 7300.

8. Connections to a subwoofer are normally made via a line-level audio connection from the **Subwoofer Output** **M** to the line-level input of a subwoofer with a built-in amplifier. When a passive subwoofer is used, the connection first goes to a power amplifier, which will be connected to one or more subwoofer speakers. If you are using a powered subwoofer that does not have line-level input connections, follow the instructions furnished with the speaker for connection information.
9. If an external multichannel audio source with 5.1 outputs such as an external digital processor/decoder, DVD-Audio or SACD player is used, connect the outputs of that device to the **8-Channel Direct Inputs** **U**.

### Video Equipment Connections

Video equipment is connected in the same manner as audio components. Again, the use of high-quality interconnect cables is recommended to preserve signal quality.

1. Connect the analog left/right audio and composite video or S-Video Play/Out jack of a VCR, personal video receiver (PVR) or DVD-recorder to the **Video 1 or Video 2 Audio and Video Input Jacks** **N O N T** on the rear panel. We recommend that VCRs and PVRs be connected to the Video 1 Input jacks as the remote control is programmed for a VCR or PVR.
2. Connect the analog left/right audio and composite video or S-Video Record/In jacks of a VCR, personal video recorder (PVR) or DVD-recorder to the **Video 1 or Video 2 Audio and Video Output Jacks** **J P M U** on the rear panel, matching the device connected to the Video 1 or Video 2 Audio and Video Inputs.
3. Connect the analog left/right audio and composite video or S-Video Play/Out jacks of any video playback device to the **Video 3 or Video 4 Audio and Video Input Jacks** **H I K V** on the rear panel. Although any type of video source device may be connected to these jacks, the remote control has the commands for the Video 3 inputs set to control a cable set-top box and the commands for the Video 4 inputs set to control a satellite receiver.

**NOTE:** The device connection recommendations shown in steps 1, 2 and 3 enable you to take advantage of the device types preprogrammed for each input on the remote control. However, if you choose to connect a different type of device you may reassign the remote codes so that they match the device by using the instruction for "Changing Devices," as shown

# INSTALLATION AND CONNECTIONS

on page 48. You may also “learn” the codes for most remotes to any input button on the remote by following the instructions for “Learning Commands” as shown on page 47.

4. Connect the analog left/right audio and composite video or S-Video and analog left/right audio outputs of a DVD player to the **DVD Audio and Video Input Jacks** **G H** on the rear panel.
5. Connect the optical or coaxial digital audio outputs of a DVD player, satellite receiver, cable box, HDTV tuner or video game to any of the **Optical or Coaxial Digital Inputs** **R T 10 12**. The recommended connection for a DVD player is to use a coaxial digital link connected to the Coaxial Digital Audio Input 1, but you may change the digital audio input assignment for any source using the **IN / OUT SETUP** menu, as described on page 23, or the **Digital Input Selector** **6 16** on the front panel or remote, as described on page 37.

**NOTE:** When connecting a device such as a digital cable box or other set-top tuner product with a digital audio output, we recommend that you connect both the digital and analog outputs of the product to your AVR. The audio input polling feature of the AVR will then be able to make certain that you have a constant audio feed, since it will automatically switch the audio input to the analog jacks if the digital feed is interrupted or not available for a particular channel.

6. If your DVD player has Y/Pr/Pb analog component video outputs, connect them to the **DVD Component Video Inputs** **F**. Although this set of inputs may be assigned to any of the five video inputs on the AVR 7300, the factory default is for this input to be assigned to the DVD. Remember to make a digital audio connection between the DVD player and the AVR, with the **Coaxial Digital Input 1** **T** being the factory default. For information on changing the input assignments for either the component video jacks or the DVD player's audio connection, see page 23.
7. If you have other devices with Y/Pr/Pb or RGB component video outputs, connect the source device to the **Component Video 1 or 2 Inputs** **G H**. The audio connections may be made to any of the analog left/right panel audio inputs or the **Optical or Coaxial Digital Inputs** **R T 10 12**. Make certain that the audio and video inputs are properly configured for their analog or digital audio connection source, in the **IN / OUT SETUP** menu, as described on page 23.
8. If the component video inputs are used, connect the **Component Video Monitor Outputs** **E** to

the component video inputs of your TV, projector or other display device.

9. If you have a camcorder, video game or other audio/video device that is connected to the AVR on a temporary, rather than permanent, basis, connect the audio, video and digital audio outputs of that device to the **Front-Panel Inputs** **10 12 14**. A device connected here is selected as the Video 5 input, and the digital inputs must be assigned to the Video 5 input. (See page 23 for more information on input configuration.)
10. When connecting the AVR 7300 to a “digital ready,” “HDTV compatible” or high-definition display (which is any device capable of accepting an input signal of 480P or higher), you are able to take advantage of the unit's advanced video processing circuitry which converts all video signals to a 480P output. Since the AVR 7300 displays the on-screen menus with upconverted video, the connection from the AVR 7300 to the display need only be one set of Y/Pr/Pb component video cables to the **Component Video Monitor Output** **E**.
11. When connecting the AVR 7300 to a standard, analog video display that has standard composite and S-Video inputs only, component video inputs may not be used. In this case, connect the **Video Monitor Output** **J** to the matching composite and S-Video inputs on your video display, depending on which types of video are used by your source devices.

**NOTE:** When source devices such as a progressive scan DVD player or HDTV set-top box are connected to the AVR 7300 via component video connections, it is also necessary to connect the standard, composite or S-Video outputs of the source device to the AVR 7300 if you wish to take advantage of the record outputs or have video routed to a second room. The record outputs and multiroom system cannot accept component inputs, nor are component inputs down-converted for use with these outputs.

## System and Power Connections

The AVR 7300 is designed for flexible use with multiroom systems, external control components and power amplifiers.

### Main Room Remote Control Extension

If the receiver is placed behind a solid or smoked glass cabinet door, the obstruction may prevent the remote sensor from receiving commands. In this event, an optional remote sensor may be used. Connect the output of the remote sensor to the **Remote IR Input** **D** jack.

If other components are also prevented from receiving remote commands, only one sensor is needed. Simply use this unit's sensor or a remote eye by running a connection from the **Remote IR Output** **C** jack to the Remote IR Input jack on Harman Kardon (or other compatible) equipment.

### Multiroom IR Link

The remote room IR receiver should be connected to the **Multiroom IR Input** **B** jack on the AVR 7300's rear panel.

If other Harman Kardon-compatible source equipment is part of the main room installation, the **Remote IR Output** **C** jack on the rear panel should be connected to the IR IN jack on source equipment. This will enable the remote room location to control source equipment functions.

**NOTE:** All remotely controlled components must be linked together in a “daisy chain.” Connect the **IR OUT** jack of one unit to the **IR IN** of the next to establish this chain.

### Multiroom Connections

The AVR 7300 is equipped with multizone capabilities that allow it to send an audio and/or video source to a remote zone that is different from the one selected for use in the main room. Please note that this capability applies to analog inputs from sources such as the AVR's tuner, tape decks or VCRs. If you wish to use a source such as a DVD or CD player that is normally connected via a digital connection, it is necessary to run an analog connection from the source to the AVR or to use the Main Downmix input option, as explained on page 44.

Depending on your system's requirement, three options are available for remote room audio connection:

**Option 1:** Use high-quality, shielded audio interconnect cable from the AVR 7300's location to the remote room. In the remote room, connect the interconnect cable to an optional external stereo power amplifier. The amplifier will be connected to the room's speakers. At the AVR 7300, plug the audio interconnect cables into the **Multiroom Audio Outputs** **C** on the AVR 7300's rear panel.

**Option 2:** Connect the **Multiroom Audio Outputs** **C** on the AVR 7300 to the inputs of an optional stereo power amplifier. Run high-quality speaker wire from the amplifier to the speakers in the remote room.

**Option 3:** Taking advantage of the AVR 7300's built-in seven-channel amplifier, it is possible to use two of the amplifier channels to power speakers in the remote room. When using this option, you will not be able to

# INSTALLATION AND CONNECTIONS

use the full 7.1-channel capabilities of the AVR 7300 in the main listening room, but you will be able to add another listening room without external power amplifiers. To use the internal amplifiers to power a remote zone, connect the speakers for the remote room location to the **Surround Back/Multiroom Speaker Outputs** **C**. Before using the remote room, you will need to configure the amplifiers for surround operation by changing a setting (following the instructions shown on page 44) in the **MULTI-ROOM SETUP** menu.

**NOTE:** For all options, you may connect an optional IR sensor in the remote room to the AVR 7300 via an appropriate cable. Connect the sensor's cable to the **Multiroom IR Input** **B** on the AVR 7300 and use the Zone II remote to control the room volume. Alternatively, you may install an optional volume control between the output of the amplifiers and the speakers.

## Multiroom Video Connections

The AVR 7300's multiroom system is designed to send both video and audio signals to a remote room location. This may be the same source that is in use in the main room, or you may select a separate input source through the Multiroom menus or remote, as explained on page 45.

The only additional connection required to add video capabilities to your multiroom system is to connect the **Multiroom Video Outputs** **Q** either directly to the video display in the remote room or to any optional video distribution amplifiers that may be required when the length of the connection cable is such that additional amplification is required.

The following items may be of additional assistance when using video as part of a multiroom system with the AVR 7300:

- Component video sources may not be routed through the multiroom system. When using a component video device, you should also make a composite or S-Video connection to permit use of the multiroom system.
- As with all cable installations, when running any wiring inside a wall be certain that the cable carries the proper NEC rating for the application. The use of improperly rated cables may present a safety hazard. Consult a qualified installer or licensed electrician should you have any questions about the use of in-wall cables for video or audio.
- When connecting the AVR 7300 to the remote room video display, be aware of the distance limitations that may exist for both composite and S-Video connections. Although the use of low-loss coax for composite video and higher-grade S-Video cables may reduce signal loss, optional dis-

tribution amplifiers may occasionally be required when long cable runs are used.

## A-BUS® Installation Connections

The AVR 7300 is among the very few receivers available today that offer built-in A-BUS Ready® operation. When used with an optional A-BUS keypad or control module, you have all the benefits of remote zone operation without the need for an external power amplifier.

To use the AVR 7300 with an approved A-BUS product, simply connect the keypad or module that is in the remote room to the AVR 7300 using standard Category 5 wiring that is properly rated for the in-wall use specific to the installation. Terminate the wiring at the receiver end to a standard RJ-45 connector, in compliance with the instructions furnished with the A-BUS module.

No further installation or adjustment is needed, as the A-BUS jack on the AVR 7300 routes the signals in and out of the keypad to their proper destination for power, signal source and control. The output fed to the A-BUS jack is determined by the AVR 7300's multiroom system and menus.

## RS-232 Connections

The AVR 7300 is equipped with an **RS-232 Port** **S** that may be used for two purposes. When the port is connected to a compatible, optional, external computer, keypad or control system, the AVR 7300 is capable of bi-directional communications that enable the external system to control the AVR; and the AVR is able to report status and handshake data back to the controller. Use of the RS-232 port for this type of control requires specific technical knowledge, and we recommend that any connection and programming for control be made by a trained installer or technician familiar with the equipment being used.

The RS-232 port may also be used as an access point through which the AVR 7300's operating system and surround mode memories may be updated via connection to a compatible computer. At the time that an upgrade is available, instructions for making the connection and installing the upgrade will be available through the Product Support area of the Harman Kardon Web site at [harmankardon.com](http://harmankardon.com).

The physical connection to the AVR 7300's RS-232 port is a standard D-SUB 9 connection but to ensure compatible and proper operation, specific software commands and pin wiring schemes may be required.

## Trigger Jack Connection

The AVR 7300 is equipped with a low-voltage **Amp Trigger Jack** **A** that may be used to activate optional, external power amplifiers, screen motors, motorized blinds or other compatible products that may be part of a home theater installation. Once the connections

are made, operation is seamless in that the low-voltage control signal is sent to the screen, blinds or other device when the AVR 7300 is turned on, and it is turned off along with the AVR. **Due to the complexity of interfacing with power-controlled devices, we strongly recommend that the installation be done by a qualified installer.**

The AVR 7300's trigger jack is a 3.5mm mono miniplug that delivers a 6-volt DC signal to the center pin ("tip") of the plug (+) with the outer shaft ("ring") of the plug as the negative (-) or ground connection. After checking for polarity, voltage and current draw compatibility between the AVR and the product to be controlled, simply connect the miniplug to the **Amp Trigger Jack** **A** on one end and to the device to be controlled on the other. No further programming is required.

## AC Power Connections

The AVR 7300 features a removable power cord that allows wires to be run in advance to a complex installation so that the unit itself need not be installed until it is ready for connection. When all needed connections have been made, connect the AC Power cord to the **AC Power Cord Jack** **P**.

The AVR 7300 draws significantly more current than other household devices, such as computers, that use removable power cords. For that reason, it is important that only the cord supplied with the unit (or a direct replacement of identical capacity) be used.

The **Switched AC Accessory Outlet** **R** is powered only when the unit is on. This is recommended for devices that have a mechanical power switch that may be left in the "ON" position.

**NOTE:** Many audio and video products go into a Standby mode when they are used with switched outlets. This type of product may not operate properly when used with the switched outlet.

The **Unswitched AC Accessory Outlet** **Q** is powered as long as the AVR is plugged into a powered AC outlet.

Once the power cord is connected, you are almost ready to enjoy the AVR 7300's incredible power and fidelity!



# OPERATION

## Basic Operation

Once you have completed the initial setup and configuration of the AVR 7300, it is simple to operate and enjoy. The following instructions will help you maximize the enjoyment of your new receiver:

### Turning the AVR 7300 On or Off

- When using the AVR 7300 for the first time, you must press the **Main Power Button** **▲** to turn the unit on. This places the unit in a Standby mode, as indicated by the lighting surrounding **Standby/On Button** **1** turning amber. Once the unit is in Standby, you may begin a listening session by pressing the **Standby/On Button** **1** on the front panel, or the **Power On Button** **2** or **AVR Selector** **5 B** on the remote. This will turn the unit on and return the DPR to the input source that was last used. The unit may also be turned on from Standby by pressing any of the **Input Selector Buttons** **4 34 45 C D** on the remote or the **Input Source Selector Button** **7** on the front panel.

Whenever the AVR is turned on, you will see all of the front-panel indicators light up for a few seconds. This is normal, and it is part of the unit's power-on self test.

**NOTE:** After pressing one of the **Input Selector Buttons** **4 34 45 C D** to turn the unit on, press the **AVR Selector** **5 B** to set the remote control to the AVR 7300 functions.

To turn the unit off, simply press the **Standby/On Button** **1** on the front panel or the **Power Off Button** **1 A** on the remote. Power will be shut off to any equipment plugged into the rear-panel **Switched AC Accessory Outlets** **R** and the lighting surrounding **Standby/On Button** **1** will turn amber.

When the remote is used to turn the unit "off," it is actually placing the system in a Standby mode, as indicated by the amber lighting of the **Standby/On Indicator** **1**.

- To program the AVR 7300 for automatic turn-off, press the **Sleep Button** **29** on the remote. Each press of the button will decrease the time before shut-down in the following sequence:

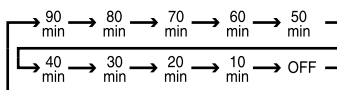

The sleep time will be displayed in the **Lower Display Line** **14** and it will count down until the time has elapsed.

The front-panel display will dim to half brightness when the Sleep function is programmed. To cancel the Sleep function, press and hold the **Sleep Button** **29** until the information display returns to normal brightness; and the words **SLEEP OFF** will appear in

the **Lower Display Line** **14**. When the programmed sleep time has elapsed, the unit will turn off.

When you will be away from home for an extended period of time, it is always a good idea to turn the unit off with the front-panel **Main Power Switch** **▲**.

**NOTE:** All preset memories are lost if the unit is left turned off by using the **Main Power Switch** **▲** for more than four weeks.

## Source Selection

- To select a source, press any of the **Input Selector Buttons** **4 34 45 C D** on the remote.
- The input source may also be changed by pressing the front-panel **Input Source Selector Button** **7**. Each press of the button will move the input selection through the list of available inputs.
- When a new input is selected, the AVR will automatically switch to the audio and video configurations that were in effect the last time that input was used. If the **BASS MGR** line on the **SPEAKER SETUP** menu (Figure 7) was set to **INDEPENDENT**, as described on page 27, the settings for speaker size will also change to the preset values.
- The front-panel **Video 5 Inputs** **▲4**, **Optical Digital 4 Input** **▲10** or the **Coaxial Digital 4 Input** **▲12** may be used to connect a device such as a video game or camcorder to your home entertainment system on a temporary basis.
- As the input source is changed, the new input name will appear momentarily as an on-screen display in the lower third of the video display. The input name will also appear in the **Upper Display Line** **13** and in the front-panel **Input Indicators** **11**.
- When an audio source is selected, the last video input used remains routed to the **Video 1/Video 2 Video Outputs** **M U** and **Video Monitor Outputs** **J**. This permits simultaneous viewing and listening to different sources.

**NOTE:** While switching sources you will see the video signal occasionally switch to black for a second or two and hear a slight clicking noise. Both of these are normal and do not indicate any problem with either the AVR 7300 or your video display. When your screen goes black you are seeing the video equivalent of an audio mute, which is put into place by the video processing system while the individual parameters for each input are retrieved from the memory and applied to the system. The clicking noise is due to the use of relays in the component video switcher to assure max-

imum video quality and to reduce the possibility of video crosstalk.

## 6-Channel/8-Channel Direct Input

- There are four input choices available for use with sources such as a DVD-Audio or SACD player that are connected to the **8-Channel Direct Inputs** **8**. Select the appropriate input for your system and source equipment:
  - The **6 CH DIRECT** input should be used when the SBR and SBL inputs are NOT in use and the source device has its own internal bass management system. This input passes the input from the source directly through to the volume control without any analog to digital conversion and it mutes the unused input jacks to prevent unwanted noise from interfering with system performance.
  - The **6 CH DVD AUDIO** input should be used when the SBR and SBL inputs are NOT in use and the source device does NOT have its own internal bass-management system. When this input is in use, the analog source is converted to digital so that you may use the same bass-management options for the direct input as you do with all other outputs. This input also mutes the unused input jacks to prevent unwanted noise from interfering with system performance.
  - The **8 CH DIRECT** input should be used when an input is connected to all eight **8-Channel Direct Inputs** **8** and when the source device has its own internal bass management system. This input passes the input from the source directly through to the volume control without any analog to digital conversion and it mutes the unused input jacks to prevent unwanted noise from interfering with system performance.
  - The **8 CH DVD AUDIO** input should be used when an input is connected to all eight **8-Channel Direct Inputs** **8** and the source device does NOT have its own internal bass management system. When this input is in use, the analog source is converted to digital so that you may use the same Quadruple Crossover bass-management options for the direct input as you do with all other outputs. This input also mutes the unused input jacks to prevent unwanted noise from interfering with system performance.

## OPERATION

## Volume and Tone Control

- Adjust the volume to a comfortable level using the front-panel **Volume Control** **10** or remote **Volume Up/Down Buttons** **18** **1**.
- To temporarily silence all speaker outputs, press the **Mute Button** **33** **⏸**. This will interrupt the output to all speakers and the headphone jack, but it will not affect any recording or dubbing that may be in progress. When the system is muted, the word **MUTE** will flash in the on-screen display and **Upper Display Line** **13**, press the **Mute Buttons** **33** **⏸** again to return to normal operation.
- The unit's tone controls may be taken out of the signal path by pressing the **Tone Mode Button** on the front panel **3** or the remote **32**. The first press of either button will show a message in the on-screen display and **Lower Display Line** **14** with the current status of the tone controls. The system default is **TONE IN**, which indicates that the bass and treble controls are active. Press the **▲/▼ Navigation Button** **15** on the remote or the **◀▶ Button** **8** on the front panel to change the setting to **TONE OUT**, which is "flat" response without the tone controls being active.
- When the tone controls are active, the bass and treble boost/cut may be adjusted by first pressing the **Tone Mode Button** on the front panel **3** or the remote **32** until the desired setting (**BASS MODE** or **TREBLE MODE**) appears in the on-screen display and the **Lower Display Line** **14**. Next, use the **▲/▼ Navigation Button** **15** on the remote or the **◀▶ Button** **8** on the front panel to change the setting as desired. The unit will return to normal operation within five seconds after the setting is changed.
- For private listening, simply place a standard 1/4" stereo headphone plug or adaptor into the **Headphone Jack** **2** behind the door **9** on the front panel. The speakers will automatically mute and the audio output will be sent to the headphones. The **Lower Display Line** **14** will read **DOLBY H : BP**, indicating that the headphone output is in the Bypass mode, and to confirm that no processing is being used.
- When the headphones are in use, you may take advantage of the Dolby Headphone modes to bring added spaciousness to headphone listening. Press the **Dolby Mode Select Button** **44** or the **Surround Mode Selector** **3** to cycle through the three Dolby Headphone modes to select the one that you prefer.

## Video Processing

The AVR 7300 features unique combination of video scaling and processing options that are available when the unit is connected to a "digital ready" or HD capable display device. Thanks to DCDi by Faroudja technology and a series of video parameter settings that may be set and stored individually for each video input source, the AVR 7300 provides the ultimate in video, as well as audio reproduction.

To take advantage of the video processing circuits with your digital or HDTV compatible video display, simply press the **Video Processing On/Off Button** **8** on the remote or the **Set/Video Button** **4** behind the door on the front panel, hold it for a second, and then release it. This will turn on the processing circuits as noted by the brief appearance of a message reading **FAROUJJA : ON** in the **Lower Display Line** **14** and in the on-screen display. Press and hold the button again to turn the processing off.

Once the processing is turned on, it will remain on until it is turned off by pressing the **Video Processing On/Off Button** **8** on the remote or the **Set/Video Button** **4** on the front panel again and releasing it so that you see a **FAROUJJA : OFF** message.

## Surround Mode Selection

One of the most important features of the AVR 7300 is its ability to reproduce a full multichannel sound field from digital sources, analog matrix surround-encoded programs and standard stereo programs.

Selection of a surround mode is based on personal taste, as well as the type of program source material being used. For example, motion pictures or TV programs bearing the logo of one of the major surround-encoding processes, such as Dolby Surround or DTS Stereo may be played in either the Dolby Digital, Dolby Pro Logic II Cinema, Dolby Pro Logic IIx Cinema, DTS Neo:6 Cinema, or Logic 7 Cinema surround modes, depending on the source material.

**NOTE:** Once a program has been encoded with matrix surround information, it retains the surround information as long as the program is available in stereo. Thus, movies with surround sound may be decoded via any of the analog surround modes such as Pro Logic II or IIx Cinema, Logic 7 Cinema or DTS Neo:6 Cinema, when they are broadcast via conventional TV stations, cable, pay-TV and satellite transmission. Also, a growing number of TV programs, sports broadcasts and radio dramas are also recorded in surround sound.

Even when a program is not listed as carrying intentional surround information, you may find that the Pro Logic II, Logic 7 Enhanced or DTS Neo:6, VMAx and the Hall or Theater modes often deliver enveloping surround pre-

sentations through the use of the natural information present in all stereo recordings.

Surround modes may be changed at any time by using either the front panel or remote control. To select a new surround mode from the front panel, first press the **Surround Mode Group Selector Button** **2** until the desired major surround mode group such as Dolby, DTS or Logic 7 is selected. Next, press the **Surround Mode Selector Button** **3** to choose the specific individual surround mode.

To select a surround mode using the remote, press the button for the surround mode group that includes the mode you wish to choose: **Dolby** **44**, **DTS Digital** **43**, **DTS Neo:6** **41**, **Logic 7** **42**, **Stereo** **40** or **DSP Surround** **6**. The first press of the button will show the current mode from that group if it is already in use, or the first available mode if you are currently using another mode. To cycle through the available modes in that group, press the button again until the desired mode appears in the **Lower Display Line** **14**, the on-screen display and in the front-panel **Surround Mode Indicators** **15**.

The Dolby Digital, Dolby Digital EX, DTS 5.1, DTS-ES Matrix and DTS-ES Discrete modes may only be selected when a digital input is in use. In addition, when a digital source is present, the AVR 7300 will automatically select and switch to the correct mode, regardless of the mode that has been previously selected. For more information on selecting digital sources, see the Digital Audio Playback section below.

When the 6-Channel/8-Channel direct inputs are in use, there is no surround processing, as these inputs take the analog output signals from an optional, external DVD-Audio or SACD player, or another source device, and carry them straight through to the volume control.

To listen to a program in traditional two-channel stereo, using the front left and front right speakers only (plus the subwoofer, if installed and configured), press the **Stereo Mode Select Button** **40** until **SURROUND OFF** appears in the **Lower Display Line** **14**. From the front panel, press the **Surround Mode Group Selector** **2** until the Stereo modes appear in the on-screen display and **Lower Display Line** **14**. Next, press the **Surround Mode Selector Button** **3** until **SURROUND OFF** appears in the on-screen display and **Lower Display Line** **14**.

## Digital Audio Playback

Digital audio is a major advancement over analog surround processing systems. It delivers up to six discrete channels, and each channel reproduces full frequency range (20Hz to 20KHz) and offers dramatically improved

(continued on p. 37)

# OPERATION

## Surround Mode Chart



MODE	FEATURES
Dolby Digital	Available only with digital input sources encoded with Dolby Digital data. It provides up to five separate main audio channels and a special dedicated low-frequency effects channel.
Dolby Digital EX	Available when the receiver is configured for 6.1/7.1 channel operation, Dolby Digital EX is the latest version of Dolby Digital. When used with movies or other programs that have special encoding, Dolby Digital EX reproduces specially encoded soundtracks so that a full 6.1/7.1 soundfield is available. When the receiver is set for 6.1/7.1 operation and a Dolby Digital signal is present, the EX mode is automatically selected. Even if specific EX encoding is not available to provide the additional channel, the special algorithms will derive a 6.1/7.1 output.
DTS 5.1	When the speaker configuration is set for 5.1-channel operation, the DTS 5.1 mode is available when DVD, audio-only music or laser discs encoded with DTS data are played. DTS 5.1 provides up to five separate main audio channels and a special dedicated low-frequency channel.
DTS-ES 6.1 Matrix DTS-ES 6.1 Discrete	When the speaker configuration is set for 6.1/7.1 operation, playback of a DTS-encoded program source will automatically trigger the selection of one of the two DTS-ES modes. Newer discs with special DTS-ES discrete encoding will be decoded to provide six discrete, full-bandwidth channels plus a separate low-frequency channel. All other DTS discs will be decoded using the DTS-ES Matrix mode, which creates a 6.1-channel sound field from the original 5.1-channel soundtrack.
Dolby Pro Logic II Movie Music Pro Logic	Dolby Pro Logic II decodes full-range, discrete, left, center right, right surround and left surround channels from either matrix surround-encoded programs or conventional stereo sources when an analog input is in use. The Dolby Pro Logic II Movie mode is optimized for movie soundtracks, while the Pro Logic II Music mode should be used with musical selections. The Pro Logic mode re-creates original Pro Logic processing for those who prefer that presentation.
Dolby Pro Logic IIx Music Movie	Dolby Pro Logic IIx is the latest extension of Dolby Pro Logic II technology that creates a discrete 6.1 and 7.1 sound field from matrix surround or two-channel stereo sources in systems configured for surround back speakers. Both Movie and Music versions of Pro Logic IIx are available. These modes may also be applied to a six-channel source connected to the <b>8-Channel Direct Inputs</b>  so that the sound field is enhanced by adding back surround channels, as well as to enable the <b>MAIN DOWNMIX</b> option in the multiroom system so that a six channel direct input may be used as a source for the remote room.
Logic 7 Cinema Logic 7 Music Logic 7 Enhance	Exclusive to Harman Kardon for receivers, Logic 7 is an advanced mode that extracts the maximum surround information from either surround-encoded programs or conventional stereo material. When your system has been configured for use with Surround Back Speakers (see page 25), you may choose between either 7.1 or 5.1 versions of the Logic 7 modes, while only the 5.1 versions are available when there are no Surround Back Speakers. The Logic 7 C (or Cinema) mode should be used with any source that contains Dolby Surround or similar matrix encoding. Logic 7 C delivers increased center channel intelligibility, and more accurate placement of sounds with fades and pans that are much smoother and more realistic than with other decoding techniques. The Logic 7 M or Music mode should be used with analog or PCM stereo sources. Logic 7 M enhances the listening experience by presenting a wider front soundstage and greater rear ambience. Both Logic 7 modes also direct low-frequency information to the subwoofer (if installed and configured) to deliver maximum bass impact. The Logic 7 E (or Enhance) mode, available only when the 5.1 option is chosen, is an extension of the Logic 7 modes that is primarily used with musical programs. Logic 7 adds additional bass enhancement that circulates low frequencies in the 40Hz to 120Hz range to the front and surround speakers to deliver a less localized soundstage that appears broader and wider than when the subwoofer is the sole source of bass energy.
DTS Neo:6 Cinema DTS Neo:6 Music	These two modes are available with analog sources playing to create a three-channel, five-channel or six-channel surround presentation from matrix-encoded or stereo sources. Select the Cinema version of Neo:6 when a program with matrix surround encoding is present. Select the Music version of Neo:6 for optimal processing when a nonencoded, two-channel stereo program is being played.
Theater	The Theater mode creates a sound field that resembles the acoustic feeling of a standard live performance theater.
Hall 1, Hall 2	The two Hall modes create sound fields that resemble a small- (Hall 1) or medium-sized (Hall 2) concert hall.
VMAx Near VMAx Far	When only the two front-channel loudspeakers are used, VMAx delivers a three-dimensional sound space with the illusion of "phantom speakers" at the center and surround positions. The VMAx N, or "Near Field" mode should be selected when your listening position is less than five feet from the speakers. The VMAx F, or "Far Field," mode should be selected when your listening position is greater than five feet from the speakers.
Dolby Virtual Speaker Reference Wide	Dolby Virtual Speaker uses advanced technology to simulate the sonic signature of a speaker location even when there is no speaker physically present in that location. The Reference ("REF") mode activates any missing speakers to simulate a 5.1 presentation with accurate localization. The Wide mode virtualizes the locations of the front-channel speakers to create a wider image and a more enveloping sound field. It is available no matter how many speakers are present.
5-Channel Stereo 7-Channel Stereo	These modes take advantage of multiple speakers to place a stereo signal at both the front and back of a room. They place the same signal at the front-left and surround-left, and front-right and surround-right speakers. The center channel is fed a summed mono mix of the in-phase material of the left and right channels.
Surround Off (Stereo)	This mode turns off all surround processing and presents the pure left- and right-channel presentation of two-channel stereo programs. When <b>SURROUND OFF</b> is selected, the unit is in a "bypass" mode with no bass management. When <b>SURROUND OFF+DSP</b> is selected, the signal is digitized and bass management settings are applied.
Dolby Headphone DH1 DH2 DH3	Dolby Headphone enables ordinary stereo headphones to portray the sound of a five-speaker surround-playback system. The DH1 mode creates headphone presentation that resembles a small, well-damped room and is appropriate for use with both movies and music-only recordings. The DH2 mode creates a more acoustically live room particularly suited to music listening. The DH3 mode creates a larger room, more like a concert hall or movie theater.

For additional information on the specifics of surround modes and processing, information on Dolby modes may be found at [www.dolby.com/Consumer/Technologies](http://www.dolby.com/Consumer/Technologies). Information on DTS modes is available at [www.dtsonline.com/home&car/overview.php](http://www.dtsonline.com/home&car/overview.php).

dynamic range and significant improvements to signal-to-noise ratios. In addition, digital systems have the capability to deliver an additional channel that is specifically devoted to low-frequency information. This is the ".1" channel referred to when you see these systems described as "5.1," "6.1" or "7.1." The bass channel is separate from the other channels, but since it is intentionally bandwidth-limited, sound designers have given it that unique designation.

### Dolby Digital

Dolby Digital is a standard part of DVD, and high-definition (HDTV) broadcasts and is available on specially encoded LD discs and satellite broadcasts.

An optional, external RF demodulator is required to use the AVR 7300 to listen to the Dolby Digital soundtracks available on laser discs. Connect the RF output of the LD player to the demodulator and then connect the digital output of the demodulator to the **Optical** or **Coaxial Inputs**   of the AVR 7300. No demodulator is required for use with DVD players or DTS-encoded laser discs.

### DTS

DTS is a digital audio system capable of delivering 5.1 or 6.1 discrete or matrix sound field reproduction. Although both DTS and Dolby Digital are digital, they use different methods of encoding the signals, and thus they require different decoding circuits to convert the digital signals back to analog.



DTS-encoded soundtracks are available on select DVD and LD discs, as well as on audio-only DTS discs. You may use any LD or CD player equipped with a digital output to play DTS-encoded discs with the AVR 7300. All that is required is to connect the player's output to either an **Optical** or **Coaxial Input** on the rear panel   or front panel  .





In order to listen to DVDs encoded with DTS soundtracks, the DVD player must be compatible with the DTS signal, which is indicated by the "DTS Digital Out" logo on the player's front panel. Some early DVD players were not able to play DTS-encoded DVDs. This does not indicate a problem with the AVR 7300, as those players cannot pass through the DTS signal. If you're in doubt as to the capability of your DVD player to handle DTS discs, consult the player's owner's manual.

**IMPORTANT NOTE:** Many DVD players have a default setting that does not pass through the DTS data, even though the machine is capable of doing so. If your DVD player has the "DTS Digital Out" logo but does not trigger DTS playback in the AVR 7300, change the player's settings in the "Audio" or "Bitstream" configuration menu so that DTS playback is enabled. The

method for doing this will vary with each player. In some cases, the proper menu choice will be "Original" while in others it will be "DTS." Consult the owner's manual for your player to find the specific information to find the proper setting.

### Selecting a Digital Source

To utilize either digital mode, you must have properly connected a digital source to the AVR 7300. Connect the digital outputs from DVD players, HDTV receivers, satellite systems or CD players to the **Optical** or **Coaxial Inputs**  . In order to provide a backup signal and a source for analog stereo recording, the analog outputs provided on digital source equipment should also be connected to their appropriate inputs on the AVR 7300 rear panel (e.g., connect the analog stereo audio output from a DVD to the **DVD Audio Inputs**  on the rear panel when you connect the source's digital outputs).

If you have not already configured an input for a digital source using the on-screen menus as shown on page 23, first select the desired input using the remote or front-panel controls, as outlined in this manual. Next, press the **Digital Select Button**  and then using the **Navigation Button**  on the remote or the **Buttons**  on the front panel, choose any **OPTICAL** or **COAXIAL** inputs, as they appear in the **Upper Display Line**  or on-screen display. When the digital source is playing, the AVR 7300 will automatically detect which type of digital data stream is being decoded and display that information in the **Upper Display Line** .

When both a digital and an analog connection are made between a source device and the AVR, the digital input is the default. If the digital stream is not present or is interrupted, the unit will automatically switch over to the analog inputs for the selected source.

### Digital Bitstream and Surround Mode Indications

When a digital source is playing, the DPR senses the type of bitstream data that is present. Using this information, the correct surround mode will automatically be selected. For example, DTS bitstreams will cause the unit to switch to DTS decoding, and Dolby Digital bitstreams will enable Dolby Digital decoding. When the unit senses PCM data from CDs or LDs, you may select any of the standard surround modes, such as Dolby Pro Logic II or Logic 7. Since the range of available surround modes is dependent on the type of digital data that is present, the AVR 7300 shows you what type of signal is present. This will help you to understand the choice of modes.

When a digital source is first detected, the AVR 7300 will display a message to indicate the type of bitstream being received. This message will appear shortly after an input or surround mode is changed, and will remain in the **Lower Display Line**  for about five seconds

before that portion of the display returns to the normal surround mode indication.

For Dolby Digital and DTS sources, a three-digit indication will appear, showing the number of channels present in the data. An example of this type of display is 3/2/.1.

The first number in the display message indicates how many discrete front-channel signals are present.

- A "3" tells you that separate front left, center and front right signals are available. This will be displayed for Dolby Digital 5.1 and DTS 5.1 programs.
- A "2" tells you that separate front left and right signals are available, but there is no discrete center channel signal. This will be displayed for Dolby Digital bitstreams that have stereo program material.
- A "1" tells you that there is only a mono channel available in the Dolby Digital bitstream.

The middle number in the display message indicates how many discrete surround channel signals are present.

- A "3" tells you that separate, discrete left surround, center back surround and right surround signals are present. This is available only on discs with DTS-ES digital audio.
- A "2" tells you that separate surround left and right signals are available. This will be displayed for Dolby Digital 5.1 and DTS 5.1 programs.
- A "1" tells you that there is only a single, surround-encoded surround channel. This will appear for Dolby Digital bitstreams that have matrix encoding.
- A "0" indicates that there is no surround channel information. This will be displayed for two-channel stereo programs.

The last number indicates whether there is a discrete low-frequency effects (LFE) channel. This is the ".1" in the common abbreviation of "5.1" sound and it is a special channel that contains only bass frequencies.

- A ".1" tells you that an LFE channel is present. This will be displayed for Dolby Digital 5.1 and DTS 5.1 programs, as available.
- A "0" indicates that there is no LFE channel information available. However, even when there is no dedicated LFE channel, low-frequency sound will be present at the subwoofer output when the speaker configuration is set to show the presence of a subwoofer.
- The information in the right side of the display will tell you if the digital audio data contains a special flag signal that will automatically activate the appropriate 6.1 or 7.1 mode. This will be shown as EX-ON or EX-OFF for Dolby Digital bitstreams and ES-ON or ES-OFF for DTS bitstreams.

# OPERATION

When Dolby Digital 3/2/1 or DTS or DTS-ES signals are being played, the DPR will automatically switch to the proper surround mode, and no other processing may be selected. When a Dolby Digital signal with a 3/1/0 or 2/0/0 signal is detected, you may select any of the Dolby surround modes.

When **DS-0FF** appears as a message, it indicates that there is no Dolby Surround data flag in the audio bitstream. Similarly, **EX-0FF** indicates that there is no Dolby Digital EX data flag. In the case of a **DS-0FF** message, you may manually select a Dolby Pro Logic mode to add a multichannel presentation to the stereo material. In the case of the **EX-0FF** message, when your system is configured for surround back speakers you may manually select Dolby Digital EX as the processing mode to add rear surround speakers to the sound field.

It is always a good idea to check the channel data to make certain that it matches the audio logo information shown on the back of a DVD package. In some cases, you will see an indication for "2/0/0" even when the disc contains a full 5.1, or 3/2/1, signal. When this happens, check the audio output settings for your DVD player or the audio menu selections for the specific disc being played to be sure that the player is sending the correct signal to the AVR.

An **UNLOCK** message may appear in the **Lower Display Line 14**. This is your indication that the digital audio data stream has been interrupted or is no longer present. When that occurs, the unit's digital signal processor has no signal to lock onto, and is thus "unlocked." You may see this message when a DVD is first started until the stream is playing and the processor determines which mode to apply; or any time the data stream is stopped or paused, such as when the menus of some discs are displayed or when the player is switching between the different sections of a disc.

You may also see the message when a satellite receiver, cable set-top or HDTV tuner is in use if the digital audio is temporarily interrupted when channels are changed or when a cable box switches from a channel with a digital data stream to a channel with analog audio only. The **UNLOCK** message is normal, and does not indicate any problem with your receiver. Rather, it tells you that the incoming data has simply been paused or is not present for a variety of possible reasons.

## PCM Playback

PCM is the abbreviation for Pulse Code Modulation, which is the type of digital signal used for standard CD playback, and other non-Dolby Digital and non-DTS digital sources such as Mini-Disc. When a PCM signal is detected, the **Lower Display Line 14** will briefly show a message with the letters PCM, in addition to a readout of the sampling frequency of the digital signal.

In most cases, this will be **PCM 44.1kHz** or **PCM 48kHz**, though in the case of specially mastered, high-resolution audio discs, you will see a **PCM 96kHz** indication. Note that the sampling rate displayed is that of the incoming digital signal, and not the upsampled rate that may be applied to PCM sources when Dolby Pro Logic, Pro Logic II or Pro Logic IIx processing is applied, as shown on pages 25–26.

During PCM playback you may select any surround mode except one of the Dolby Digital or DTS/DTS-ES modes. However, when a CD with HDCD encoding is being played you must select the Surround Off (stereo) mode to take advantage of the HDCD process.

## HDCD Playback

High Definition Compatible Digital,<sup>®</sup> or HDCD, discs are recorded using a 20-bit encoding and other proprietary processing for the ultimate in CD listening. When an HDCD-encoded disc is playing and the CD player is connected using a digital connection, the AVR 7300 will automatically recognize the HDCD encoding and activate the circuits required for proper playback, provided that the Surround Off mode is selected. An HDCD message will appear in the **Lower Display Line 14** to confirm the HDCD playback. HDCD playback is limited to two-channel stereo only.

## Speaker/Channel Indicators

In addition to the bitstream indicators, the AVR 7300 features channel-input indicators that show how many channels of digital information are being received and/or whether the digital signal is interrupted.

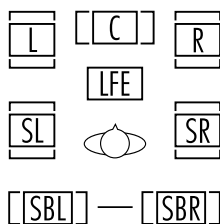

These indicators are the L/C/R/LFE/SL/SR/SBL/SBR letters that are inside the center boxes of the **Speaker/Channel Input Indicators 12** on the front panel. When a standard analog signal is in use, only the "L" and "R" indicators will light, as analog signals have only left and right channels.

Digital signals, may have two, five, six or seven channels; depending on the program material, its method of transmission and the way in which it was encoded. When a digital signal is playing, the letters in these indicators will light in response to the signal being received. It is important to note that although Dolby Digital, for example, is referred to as a "5.1" system, not all Dolby Digital DVDs or programs are encoded for 5.1. Thus, it is sometimes normal for a DVD with a

Dolby Digital soundtrack to trigger only the "L" and "R" indicators.

**NOTE:** Many DVD discs are recorded with both "5.1" and "2.0," and Dolby Digital and DTS versions of the same soundtrack. When playing a DVD, always be certain to check the type of material on the disc. Most discs show this information using icons on the back of the disc jacket. When a disc offers multiple soundtrack choices, you may have to make some adjustments to your DVD player (usually with the "Audio Select" button or in a menu screen on the disc) to send a full 5.1 feed to the AVR 7300 or to select between Dolby Digital or DTS. It is also possible for the type of signal feed to change during the course of a DVD's playback. In some cases, the previews or special material will be recorded in 2.0 audio, while the main feature is available in 5.1 audio. The AVR 7300 will automatically sense changes to the bitstream and channel count and reflect them in these indicators.

The letters used by the **Speaker/Channel Input Indicators 12** also flash to indicate when a bitstream has been interrupted. This will happen when a digital input source is selected before the playback starts, or when a digital source such as a DVD is paused. The flashing indicators, along with the **UNLOCK** message in the **Lower Display Line 14**, remind you that the playback has stopped due to the absence of a digital signal and not through any fault of the AVR 7300. This is normal, and the digital playback will resume once the playback is started again.

## Night Mode

A special feature of Dolby Digital is the Night mode, which enables specially encoded Dolby Digital input sources to be played back with full digital intelligibility while reducing the minimum peak level by 1/4 to 1/3. This prevents abruptly loud transitions from disturbing others, without reducing the impact of the digital source. The Night mode is available only when Dolby Digital signals with special data are being played.

The Night mode may be engaged when a Dolby Digital DVD is playing by pressing the **Night Mode Button 30** on the remote. Next, press the **▲/▼ Navigation Button 15** to select either the middle range or full compression versions of the Night mode. To turn the Night mode off, press the **▲/▼ Navigation Button 15** until the message in the lower third of the video display and in the **Lower Display Line 14** reads **D-RANGE OFF**.

The Night mode may also be selected to always be on at either level of compression using the options in the **DOLBY SURR** menu. See page 25 for information on using the menus to set this option.

## OPERATION

**MP3 Audio Playback**

The AVR 7300 is one of the few receivers equipped for onboard decoding for the MP3 audio format used by computers and portable audio devices. By offering MP3 decoding, the AVR 7300 is able to deliver precise conversion of the digital signals to an analog output, along with the benefits of listening to the MP3 audio through the AVR 7300's high-power amplifier and the speakers from your surround system, rather than the smaller speakers and low-powered amplifiers typically used with computers.

To take advantage of the AVR 7300's MP3 capabilities, simply connect the S/P-DIF output of a computer's sound card or the S/P-DIF output of a portable digital audio device to either the rear panel **Digital Inputs** **(F) (T)** or the front-panel **Digital Inputs** **(A) (B)**. When the digital signal is available, the **Lower Display Line** **(14)** will indicate that an MP3 bitstream is present, and the audio will begin playing.

**NOTES:**

- The AVR 7300 is only capable of playing signals in the MP3 (MPEG 1/Layer 3) format. It is not compatible with other computer audio codecs.
- The digital audio input signal may be either optical or coaxial, but the signal must be in the S/P-DIF format. Direct connection of USB or serial data outputs is not possible, even though the signals are in the MP3 format. If you have any questions about the data output format from your computer or a sound card, check with the device's owner's manual.
- If your computer or sound card's digital output is not capable of direct connection to the AVR 7300, you may use an optional, external transcoder to convert the USB output of a computer to a format compatible with the AVR.
- Due to the wide variation in MP3 formats and encoding speeds, it is possible that the AVR 7300 may not be compatible with all MP3 input signals. Some may produce unacceptable results or may not be decoded. This is not a fault of either the computer or the AVR 7300, but rather a by-product of the unpredictable nature of MP3 playback.
- Even when your computer does not have a digital output that is compatible with the AVR 7300, you may connect the analog audio output available on virtually all computers to one of the AVR's analog audio inputs using an optional adaptor cable that converts the stereo mini plug commonly used for computer audio connections to the left/right RCA jacks used on the AVR. Connecting your computer to the AVR will enable you to take advantage of

the high-quality audio reproduction possible with a home theater system, as well as enable the use of surround processing modes such as Logic 7, to greatly enhance downloaded or streaming audio playback.

**IMPORTANT NOTES ON DIGITAL PLAYBACK:**

- When the digital playback source is stopped, or in a pause, fast forward or search mode, digital audio data will momentarily stop, and the channel position letters inside the **Speaker/Channel Input Indicators** **(12)** will flash and an **UNLOCK** message may appear. This is normal and does not indicate a problem with either the AVR 7300 or the source machine. The AVR 7300 will return to digital playback as soon as the data is available.
- Some source devices, particularly cable set-top boxes, will switch back and forth between digital and analog audio outputs, depending on the channel being watched. To avoid losing sound with this type of product, it is recommended that you connect both the digital and analog audio outputs of the source to the AVR 7300, with the digital audio input set as the default following the steps shown on page 23. The AVR will monitor the digital data stream and when it is interrupted the sound will mute briefly and possibly display an **UNLOCK** message while it switches to the analog audio input. This switching is not a fault of either the AVR or the cable box, as it is caused by the use of different audio technologies on different channels by the cable company or program supplier.
- Although the AVR 7300 will decode virtually all current DVD movies, CDs and HDTV sources, it may not be compatible with future digital sources.
- When a digital source is playing, you may not be able to select some of the analog surround modes such as Dolby Pro Logic II, Dolby Pro Logic IIx, Hall, Theater or Logic 7.
- When a Dolby Digital or DTS source is playing, it is not possible to make an analog recording using the **Tape Outputs** **(D)** and **Video 1** or **Video 2 Audio Outputs** **(P) (J)**. However, the digital signals will be passed through to the **Digital Audio Outputs** **(Q) (S) (A) (B)**.

**Tuner Operation**

The AVR 7300's tuner is capable of tuning AM, FM and FM Stereo broadcast stations. Stations may be tuned manually, or they may be stored as favorite station presets and recalled from a 30-position memory.

**Station Selection**

1. Press the **AM/FM Button** **(34)** on the remote to

select the tuner as an input. The tuner may be selected from the front panel by either pressing the **Input Source Selector** **(7)** until the tuner is active or by pressing the **Tuner Band Selector** **(5)**.

2. Press the **AM/FM Button** **(34)** or **Tuner Band Selector** **(5)** again to switch between AM and FM so that the desired frequency band is selected.
3. Press the **Tuner Mode Selector** **(8) (12)** to select manual or automatic tuning.

When the button is pressed so that **AUTO** or **AUTO / STEREO** appears in the **Upper Display Line** **(13)**, each press of the **Tuning Selectors** **(4) (23)** will put the tuner in a scan mode that seeks the next higher or lower frequency station with acceptable signal strength. An **AUTO ST TUNED** indication will momentarily appear when the station stops at a stereo FM station, and an **AUTO TUNED** indication will momentarily appear when an AM or monaural FM station is tuned. Press the **Tuning Selectors** **(4) (23)** again to scan to the next station.

When the button is pressed so that **MANUAL** or **MANUAL / MONO** appears in the **Upper Display Line** **(13)**, each tap of the **Tuning Selectors** **(4) (23)** will increase or decrease the frequency by one increment. When the tuner receives a strong enough signal for adequate reception, **MANUAL TUNED** will appear in the **Lower Display Line** **(14)**.

4. Stations may also be tuned directly in either the automatic or manual mode. To enter a station's frequency directly, first select the AM or FM band as desired by pressing the **AM/FM Button** **(34)**. Next, press the **Direct Button** **(9)**. Within five seconds of when **DIRECT IN** scrolls in the **Upper Display Line** **(13)**, enter the station frequency by pressing the **Numeric Keys** **(11)**. If you press an incorrect button while entering a direct frequency, press the **Clear Button** **(10)** to start over.

**NOTE:** When the FM reception of a station is weak, audio quality will be increased by switching to Mono mode by pressing the **Tuner Mode Button** **(8) (12)** so that **MANUAL / MONO** appears momentarily in the **Upper Display Line** **(13)** and then goes out. This will also activate manual tuning mode.

**Preset Tuning**

Using the remote, up to 30 stations may be stored in the AVR 7300's memory for easy recall using the front-panel controls or the remote.

# OPERATION

To enter a station into the memory, first tune the station using the steps outlined above. Then:

1. Press the **Memory Button** **39** on the remote; the station's frequency will flash.
2. Within five seconds, press the **Numeric Keys** **11** corresponding to the memory location where you wish to store this station's frequency. Once entered, the preset number will appear in the **Upper Display Line** **13**.
3. Repeat the process after tuning any additional stations to be preset.

## Recalling Preset Stations

- To manually select a station previously entered in the preset memory, press the **Numeric Keys** **11** for the desired station's memory location.
- To manually scroll through the list of preset stations, press the **Preset Stations Selector Button** **6** **22** on the front panel or remote.

## Recording

In normal operation, the audio or video source selected for listening through the AVR 7300 is sent to the record outputs. This means that any program you are watching or listening to may be recorded simply by placing machines connected to the outputs for **Tape Outputs** **D** or **Video 1/Video 2 Outputs** **P** **J** in the record mode.

When a digital audio recorder is connected to the **Digital Audio Outputs** **Q** **S** **U** **V**, you are able to record the digital signal using a CD-R, MiniDisc or other digital recording system.

## NOTES:

- The digital outputs are active only when a digital signal is present, and they do not convert an analog input to a digital signal, or change the format of the digital signal. In addition, the digital recorder must be compatible with the output signal. For example, the PCM digital input from a CD player may be recorded on a CD-R or MiniDisc, but Dolby Digital or DTS signals may not.
- The **Front-Panel Video 5** **14** jacks may be configured for use as an output, allowing connection to a recorder, when the steps shown in the section below are followed.
- Please obey the copyright restrictions on any material you copy. Unauthorized duplication of copyrighted materials is prohibited by law.

## Front-Panel Connections

In addition to the rear-panel digital and analog outputs, the AVR 7300 offers Harman Kardon's exclusive configurable front-panel output-jack feature. For easy connection of portable devices, you may switch the front-panel **Video 5 Jacks** **14** from an input to an output by following these steps:

1. Press the **OSD Button** **31** to view the **MASTER MENU** (Figure 1).
2. Press the **Set Button** **17** to enter the **IN/OUT SETUP** menu (Figure 2).
3. Press the **Navigation Button** **15** so that the on-screen **→** cursor is next to **VIDEO 5**.
4. Press the **Set Button** **17** and then press the **Navigation Button** **15** so that the word **OUT** is highlighted.
5. Press the **Set Button** **17** to enter the change.
6. Press the **OSD Button** **31** to exit the menus and return to normal operation.

Once the setting is made, the **Input/Output Status Indicator** **5** will turn red, indicating that the jacks are now an output, instead of in the default setting as an input. Once changed to an output, the setting will remain as long as the AVR 7300 is turned on, unless the setting is changed in the OSD menu system, as described above. However, once the AVR 7300 is turned off, the setting is cancelled. When the unit is turned on again, the front-panel jacks will return to their normal default setting as an input. If you wish to use the jacks as an output at a future time, the setting must be changed again using the OSD menu system, as described above.

## Output Level Trim Adjustment

Normal output level adjustment for the AVR 7300 is established using the test tone, as outlined on pages 29–30. In some cases, however, it may be desirable to adjust the output levels using program material such as a test disc, or a selection you are familiar with. Additionally, the output level for the subwoofer can only be adjusted using this procedure.

To adjust the output levels using program material, first set the reference volume for the front left and front right channels using the **Volume Control** **10** **18** **1**.

If you are using a disc with test signals or an external signal generator as the source used when the output levels are being trimmed, you may use the remote as an SPL meter to guide you to the correct level settings. To use the EzSet remote as an SPL meter, follow the instructions on page 29.

Once the reference level has been set, press the **Channel Select Button** **14** and **FRONT LEVEL** will appear in the **Lower Display Line** **14**. To change the level, first press the **Set Button** **17**, and then use the **Navigation Button** **15** to raise or lower the level. DO NOT use the volume control, as this will alter the reference setting.

Once the change has been made, press the **Set Button** **17** and then press the **Navigation Button** **15** to select the next output-channel location that you wish to adjust. To adjust the subwoofer level, press the **Navigation Button** **15** until **WOOFER LEVEL** appears in the **Lower Display Line** **14** or on-screen display.

Repeat the procedure as needed until all channels requiring adjustment have been set. When all adjustments have been made and no further adjustments are made for five seconds, the AVR 7300 will return to normal operation.

The channel output for any input may also be adjusted using the full-OSD on-screen menu system. First, set the volume to a comfortable listening level using the **Volume Control** **10** **18** **1**. Then, press the **OSD Button** **31** to bring up the **MASTER MENU** (Fig. 1). Press the **Navigation Button** **15** until the on-screen **→** cursor is next to the **CHANNEL ADJUST** line. Press the **Set Button** **17** to activate the **CHANNEL ADJUST** menu (Fig. 13).

Once the menu appears on your video screen, first use the **Navigation Button** **15** to move the on-screen **→** cursor so that it is next to the **TEST TONE** line. Press the **Navigation Button** **15** so that **OFF** is highlighted. This will turn off the test tone and allow you to use your external test disc or other source material as the reference. Then, use the **Navigation Button** **15** to select the channels to be adjusted. At each channel position, use the **Navigation Button** **15** to change the output level. Remember, the goal is to have the output level at each channel be equal when heard at the listening position.

If you wish to reset all the levels to their original factory default of 0dB offset, press the **Navigation Button** **15** so that the on-screen cursor is next to the **CHANNEL RESET** line and press the **Navigation Button** **15** so that the word **ON** is highlighted. After the levels are reset, resume the procedure outlined above to reset the levels to the desired settings. When all adjustments are done, press the **Navigation Button** **15** to move the on-screen **→** cursor so that it is next to **BACK TO MASTER MENU** and then press the **Set Button** **17** if you wish to go back to the main menu to

make other adjustments. If you have no other adjustments to make, press the **OSD Button** **41** to exit the menu system.

**NOTE:** Output levels may be separately trimmed for each surround mode. If you wish to have different trim levels for a specific mode, select that mode and then follow the instructions shown above.

### Dim Function

Since the AVR 7300 will often be used when movies or other video programming is viewed under low-light conditions, you may wish to lower the brightness of the front-panel displays and indicators so that they do not distract from the video presentation. You may dim the displays using the menu system, as shown on page 42, or you may control the brightness directly from the remote.

Simply press the **Dim Button** **13** once to dim the front panel to half the normal brightness level; press it again to turn the displays off. Note that when the displays are dimmed or turned off, the lighting around the **Standby/On Button** **1** will remain lit as a reminder that the AVR is still turned on.

Note that all changes to the front-panel brightness level remain in effect only until the AVR is turned off; the displays will return to full brightness after the AVR is turned on again. To return the displays to full brightness without turning the unit off, press the **Dim Button** **13** as needed until the displays are on.

In addition to lowering the brightness of the displays or turning them off completely, you may wish to have them appear whenever a button on the remote or front panel is pushed, and then gradually fade out after a set time period. You may do this by making the appropriate settings in the **VFD FADE TIME OUT** line of the **ADVANCED SELECT** Menu (Figure 19), as shown on page 42.

### Memory Backup

This product is equipped with a memory backup system that preserves the system configuration information and tuner presets if the unit is accidentally unplugged or subjected to a power outage. This memory will last for at least four weeks, after which time all information must be reentered.



## TROUBLESHOOTING GUIDE

SYMPTOM	CAUSE	SOLUTION
Unit does not function when Main Power Switch is pushed	<ul style="list-style-type: none"> <li>No AC Power</li> </ul>	<ul style="list-style-type: none"> <li>Make certain that the AC power cord is plugged into a live outlet</li> <li>Check to see whether the outlet is switch-controlled</li> </ul>
Display lights, but no sound or picture	<ul style="list-style-type: none"> <li>Intermittent input connections</li> <li><b>Mute</b> is on</li> <li>Volume control is down</li> </ul>	<ul style="list-style-type: none"> <li>Make certain that all input and speaker connections are secure</li> <li>Press <b>Mute Button</b> <b>33</b></li> <li>Turn up the volume control</li> </ul>
Unit turns on, but front-panel display does not light up	<ul style="list-style-type: none"> <li>Display brightness is turned off</li> </ul>	<ul style="list-style-type: none"> <li>Follow the instructions in the Display Brightness section on page 42 so that the display is set to <b>VFD FULL</b></li> </ul>
No sound from any speaker; light around power switch is red	<ul style="list-style-type: none"> <li>Amplifier is in protection mode due to possible short</li> <li>Amplifier is in protection mode due to internal problems</li> </ul>	<ul style="list-style-type: none"> <li>Check speaker wire connections for shorts at receiver and speaker ends</li> <li>Contact your local Harman Kardon service center</li> </ul>
No sound from surround or center speakers	<ul style="list-style-type: none"> <li>Incorrect surround mode</li> <li>Input is monaural</li> <li>Incorrect configuration</li> <li>Stereo or Mono program material</li> </ul>	<ul style="list-style-type: none"> <li>Select a mode other than Stereo</li> <li>There is no surround information from mono sources</li> <li>Check speaker mode configuration</li> <li>The surround decoder may not create center- or rear-channel information from nonencoded programs</li> </ul>
Unit does not respond to remote commands	<ul style="list-style-type: none"> <li>Weak batteries in remote</li> <li>Wrong device selected</li> <li>Remote sensor is obscured</li> </ul>	<ul style="list-style-type: none"> <li>Change remote batteries</li> <li>Press the AVR selector</li> <li>Make certain that the front-panel sensor is visible to the remote, or connect remote sensor</li> </ul>
Intermittent buzzing in tuner	<ul style="list-style-type: none"> <li>Local interference</li> </ul>	<ul style="list-style-type: none"> <li>Move the unit or antenna away from computers, fluorescent lights, motors or other electrical appliances</li> </ul>
An <b>UNLOCK</b> message appears in the display and/or the letters in the Channel Indicator display flash at the same time as the audio stops	<ul style="list-style-type: none"> <li>The type of digital audio stream has been changed</li> <li>Digital audio feed paused</li> </ul>	<ul style="list-style-type: none"> <li>Wait a second or two for the unit's processor to recognize the new data stream and automatically resume playback</li> <li>Resume DVD playback.</li> </ul>

In addition to the items shown above, additional information on troubleshooting possible problems with your AVR 7300, or installation-related issues, may be found in the list of "Frequently Asked Questions" which is located in the Product Support section of our Web site at [www.harmankardon.com](http://www.harmankardon.com).

## Processor Reset

In the rare case where the unit's operation or the displays seem abnormal, the cause may involve the erratic operation of the system's memory or microprocessor.

To correct this problem, first unplug the unit from the AC wall outlet and wait at least three minutes. After the pause, reconnect the AC power cord and check the unit's operation. If the system still malfunctions, a system reset may clear the problem.

To clear the AVR 7300's entire system memory including tuner presets, output level settings, delay times and speaker configuration data, first put the unit

in Standby by pressing the **Standby/On Button** **1**. Next, press and hold the **Surround Mode Group Selector** **2** and the **Tuner Mode Selector** **3** buttons for three seconds.

The unit will turn on automatically and display the **RESET** message in the **Upper Display Line** **14**.

**NOTE:** Resetting the processor will erase any configuration settings you have made for speakers, output levels, surround modes, digital input assignments as well as the tuner presets. After a reset the unit will be returned to the factory presets, and all settings for these items must be reentered.

If the system is still operating incorrectly, there may have been an electronic discharge or severe AC line interference that has corrupted the memory or microprocessor.

If these steps do not solve the problem, consult an authorized Harman Kardon service center.

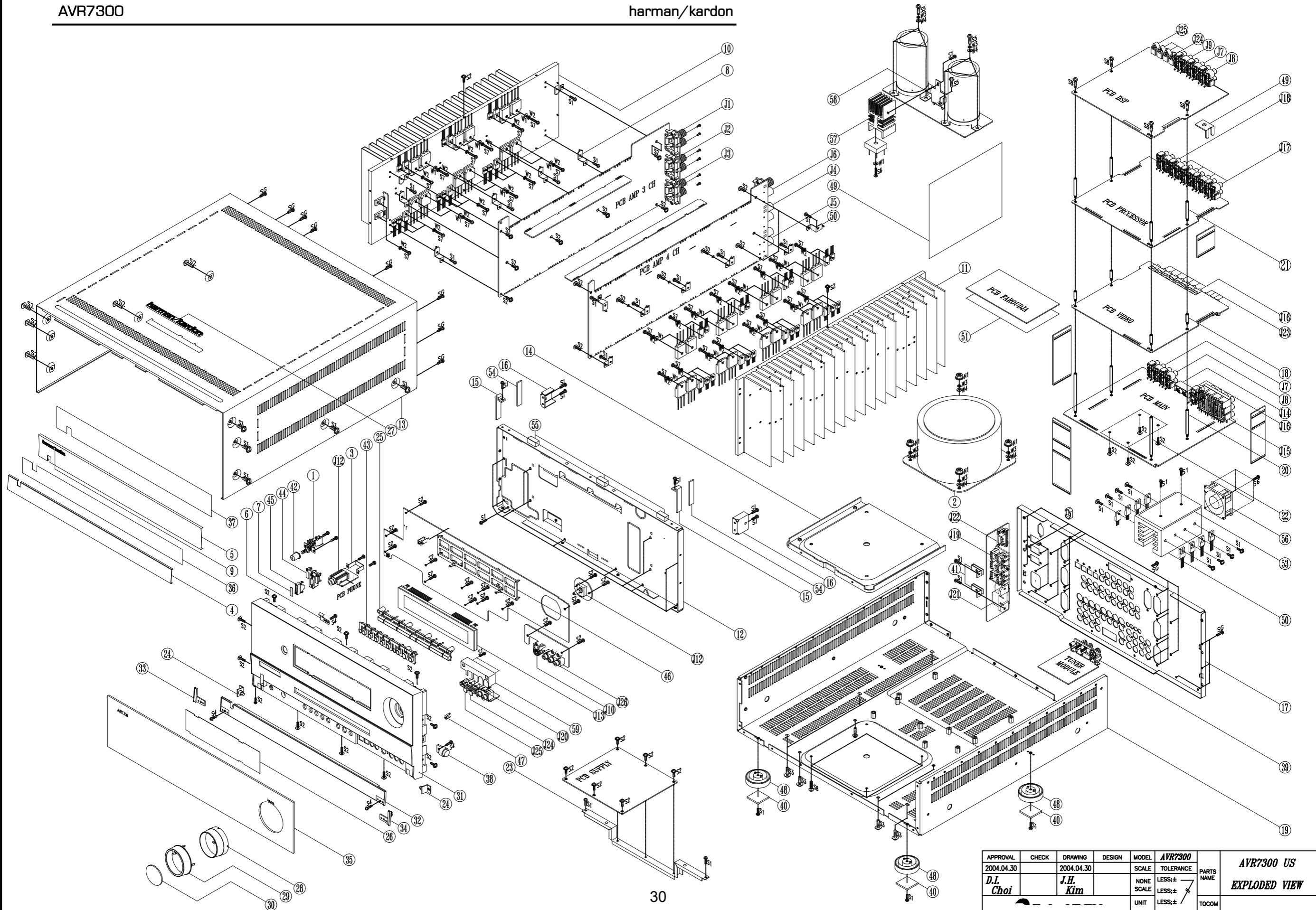

APPROVAL	CHECK	DRAWING	DESIGN	MODEL	AVR7300	PARTS NAME	AVR7300 US EXPLODED VIEW
2004.04.30		2004.04.30		SCALE	TOLERANCE	TOCOM NO.	
				NONE SCALE	LESS;±		
				UNIT	LESS;±		
				m/m	LESS;±		

<b>AVR7300 Exploded View Parts List</b>			
No.	Part No.	Description	Q'ty
1	H01-SWA2B21PDA&-7	SW PUSH POWER SDDL15700	1
2	H01-TXPWMMMD05B0-5	MN X'FORMER AVR7300 120V TRANSFORMER	1
3	H01-ZMB01S00100-5	BKT HEADPHONE JACK	1
4	H01-ZMD05S02A00-1	AL DOOR AVR7300	1
5	H01-ZMC11S00300-2	AL PANEL AVR430/630	1
6	H01-ZMC11S06A00-3	SPRING STOPPER AVR430/630	1
7	H01-ZMC11S12A00-8	CAP BUTTON STAND-BY AVR430/630	1
8	H01-ZMC12S09A00-4	BKT HEATSINK	15
9	H01-ZMC12S20A00-2	BADGE AL HARMAN/KARDON SILVER	1
10	H01-ZMD05S03A00-2	HEATSINK 3CH AVR7300	1
11	H01-ZMD05S04A00-3	HEATSINK 4CH AVR7300	1
12	H01-ZMD05S07A00-6	CHASSIS FRONT AVR7300	1
13	H01-ZMD05S08A00-7	COVER TOP AVR7300	1
14	H01-ZMD05S08B00-9	BKT TRANS BOTTOM AVR7300	1
15	H01-ZMD05S09A00-8	BKT TOP	2
16	H01-ZMD05S10A00-8	BKT SIDE	2
17	H01-ZMD05S11A00-9	PANEL REAR AVR7300US	1
18	H01-ZMD05S12AYE-8	STUD STANDOFF HEX M4X0.7 6X15H	2
19	H01-ZMD05S13A00-0	CHASSIS MAIN AVR7300	1
20	H01-ZMD05S13AYE-9	STANDOFF HEX M4X0.7 6X55H	2
21	H01-ZMD05S14AYE-A	STANDOFF HEX M4X0.7 6X34H	4
22	H01-ZMD05S15AYE-0	STUD STANDOFF HEX M4X0.7 6X71.6H	2
23	H01-ZMD05S15A00-2	BKT SUPPLY	1
24	H01-ZMD05S16A00-3	BKT HINGE AVR7300	2
25	H01-ZPC1004GASG-0	BUTTON 7 KEY	1
26	H01-ZPC1018GART-7	FILTER VFD	1
27	H01-ZMGEN00GAGY-0	AL LOGO BADGE TOP	1
28	H01-ZPD0515GAMW-A	VOLUME KNOB	1
29	H01-ZPD0316GASG-A	COVER KNOB	1
30	H01-ZPD0317GACR-4	CAP KNOB VOLUMN	1
31	H01-ZPD0501GAGY-9	FRONT PANEL AVR7300	1
32	H01-ZMD05S17A00-4	AL DOOR PANEL AVR7300	1
33	H01-ZPD0503GAGY-5	FRAME DOOR L	1
34	H01-ZPD0504GAGY-3	FRAME DOOR R	1
35	H01-ZPD0522GABT-3	WINDOW DISPLAY AVR7300	1
36	H01-ZVC11DWT100-3	TAPE DOOR	1
37	H01-ZVC11DWT200-5	TAPE PANEL	1
38	H01-ZVC11GEAR01-A	DAMPER GEAR DP120	1
39	H01-ZVC11TUNE01-7	TUNER MODULE KST-MB011MW0-81 US	1
40	ZFNR19720SB-5	RUBBER FOOT 19.7X19.7X2T BK	4
41	H01-ZMC12S19A00-2	BKT AC INLET	2
42	ZPD0503GAGY-7	BUTTON POWER	1
43	ZPC1005GAGY-8	BUTTON 8 KEY	1
44	ZPC1006GAWH-0	BUTTON STANDBY	1
45	ZPC1007GAMW-9	INDICATOR STAND-BY	1
46	ZPC1017GABK-6	HOLDER VFD AVR430/630	1
47	ZPC1102GAMW-1	INDICATOR VIDEO 4	1
48	ZPC1103GAGY-A	FOOT 50MM 15.8MM	4
49	H01-ZMD05S19A00-6	BRACKET SHIELD LARGE	1
50	H01-ZMD05HS0300-0	HEATSINK REG.TR AVR7300	1
51	H01-ZMD05S05A00-4	SHIELD FAROUDJA	1
52	H01-ZMD05S20A00-6	SHIELD LARGE AVR7300	1
53	H01-ZMD05S21A00-7	SHIELD SMALL AVR7300	2
54	ZFNR1450300-A	RUBBER TOP	2
55	ZQB0101AA00-4	SHIELD FOAM GASKET (WOORI)	2
56	ZUC1202AABK-3	SPONGE 145X11X2T BK	1
57	H01-ZMD05HS0100-7	HEATSINK BRIDGE AVR7300	1
58	H01-ZMD05S06A00-5	BRACKET BRIDGE H/SINK AVR7300	1
59	H01-ZMD05S18A00-5	SHIELD DIGITAL AVR7300	1

<b>AVR7300 Exploded View Parts List</b>			
No.	Part No.	Description	Q'ty
J1	H01-SOSP20117NN-6	JACK SPEAKER 2P B30290117N BK/WH	1
J2	H01-SOSP20118NN-8	JACK SPEAKER 2P B30290118N BK/BU	1
J3	H01-SOSP20119NN-A	JACK SPEAKER 2P B30290119N BK/BRN	1
J4	H01-SOSP20115NN-2	JACK SPEAKER 2P B30290115N GY/BK D/N	1
J5	H01-SOSP20116NN-4	JACK SPEAKER 2P B30290116N TAN/BK	1
J6	H01-SOSP40164NN-1	JACK SPEAKER 4P B30490164N GN/BK/R/B	1
J7	H01-SORA40RSANN-6	JACK RCA 4P JB040131ZN GN BN PP TA	2
J8	H01-SORA40RSCNN-A	JACK RCA 4P JB040131QN WH BU RD GY	3
J9	H01-SOJB04013HN-5	JACK RCA 4P OR ,OR, OR, OR JB040131HN	2
J10	H01-SORA8OSC5N8-2	JACK S-VIDEO 1P C40160261N	1
J11	H01-SOSS9CKX3NN-9	JACK PHONE 6.35 H70980110S 9P BK	1
J12	H01-SWE3AEC11S1-8	VOLUME ENCODER EC11B20203	1
J13	H01-VDHCA18LL03-7	FL HCA-18LL03	1
J14	SOMOD7400NN-6	JACK MODULAR 7400-621002	1
J15	H01-SOR12BJ12NN-3	JACK RCA 12P BJ120154JN	1
J16	H01-SORA11Y00NN-5	JACK RCA+S VIDEO C5016031DN	9
J17	H01-SORA40GNDNN-7	JACK RCA 4P JB040131PN WWRR	4
J18	H01-SORA64105NN-5	JACK RCA 6P JB060132PN	1
J19	H01-SOAC3A206NN-5	JACK AC OUTLET 3P A206D0054P	1
J20	H01-SORA21502NN-2	CON PHONO SCKT RCA 2P W/GNDCAP CJ020009	1
J21	H01-SOXA27014NN-9	CON MAINS INLET A/C INLET 7014-NGP AC05-4S0	1
J22	SOPA96063NN-0	JACK D-SUB 9P 87204-6063 W/DUST COVER BK	1
J23	H01-SOJW2350SNN-A	JACK PHONE 3.6 EP-1401A 1P BK	4
J24	H01-SOTOR179LBA-0	D-LEM TORX-179L	4
J25	H01-SOTOT179LBA-7	D-LEM TOTX-179L	2
J26	H01-SORA3313PNN-3	CON PHONO SCKT RCA-313P 3 PINS	
S5	ZSMWM4008BZ-2	SCREW M.S M4X8 W/H ZN PLATED	11
S6	ZSTBM0318TZ-3	SCREW ST BH 3X18	3
S4	ZSTBM3008BY-1	SCREW ST BH 3X8	3
S1	ZSTBM3010BB-5	SCREW ST BH 3X10	62
S7	ZSTBM3012BY-A	SCREW ST BH 3X12 PIVOT	63
SG	ZSTGM3010BB-3	SCREW ST BH 3X10 GROUND	65
S2	ZSTWM3008BY-8	SCREW ST WPH 3X8	55
S3	ZSTWM4008BC-3	SCREW ST WPH 4X8 SILVER CHROM	20
S8	ZSMCM4014BN-6	SCREW MC4X14 NI PLATED	4
W2	ZWM623108SZ-2	WASHER SPRING 3	64
W1	ZWM803305PZ-1	WASHER PLAIN 3	31
W4	ZWMC04810PZ-5	WASHER PLAIN 4	4
W3	ZWM763109SZ-2	AC SPRING WASHER RT2250(PAV5005)	4
N1	ZNSSM4045HZ-4	NUT M4 HEXAGON CIRCULAR EXTERNAL	4

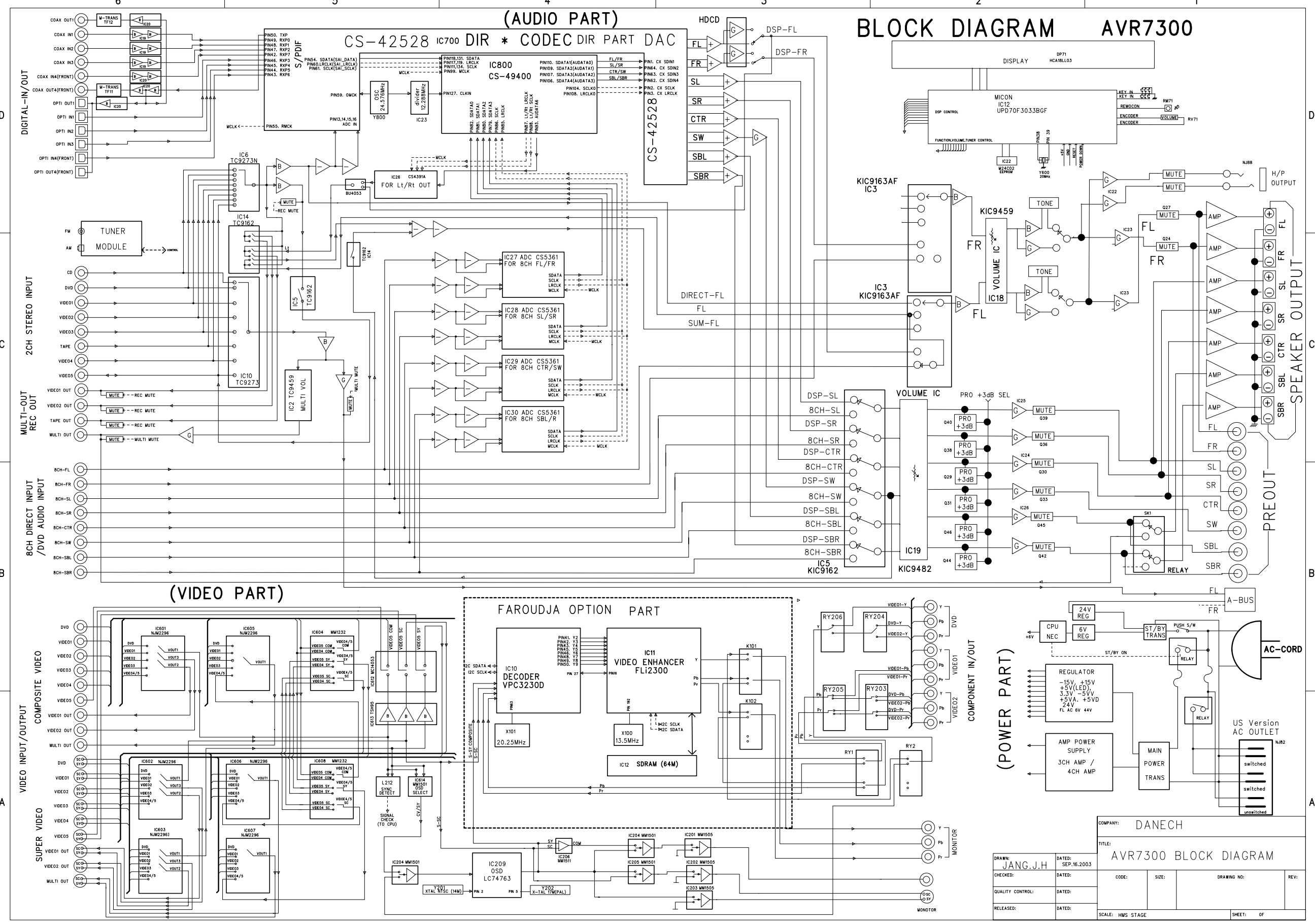

**(AUDIO PART)**

**BLOCK DIAGRAM AVR7300**

**(VIDEO PART)**

**FAROUDJA OPTION PART**

**(POWER PART)**

COMPANY: DANECH

TITLE: AVR7300 BLOCK DIAGRAM

DRAWN: JANG.J.H      DATED: SEP.16.2003

CHECKED:	DATED:	CODE:	SIZE:	DRAWING NO:	REV:
QUALITY CONTROL:	DATED:				
RELEASED:	DATED:				

SCALE: HMS STAGE      SHEET: OF

1. SURROUND CIRCUIT

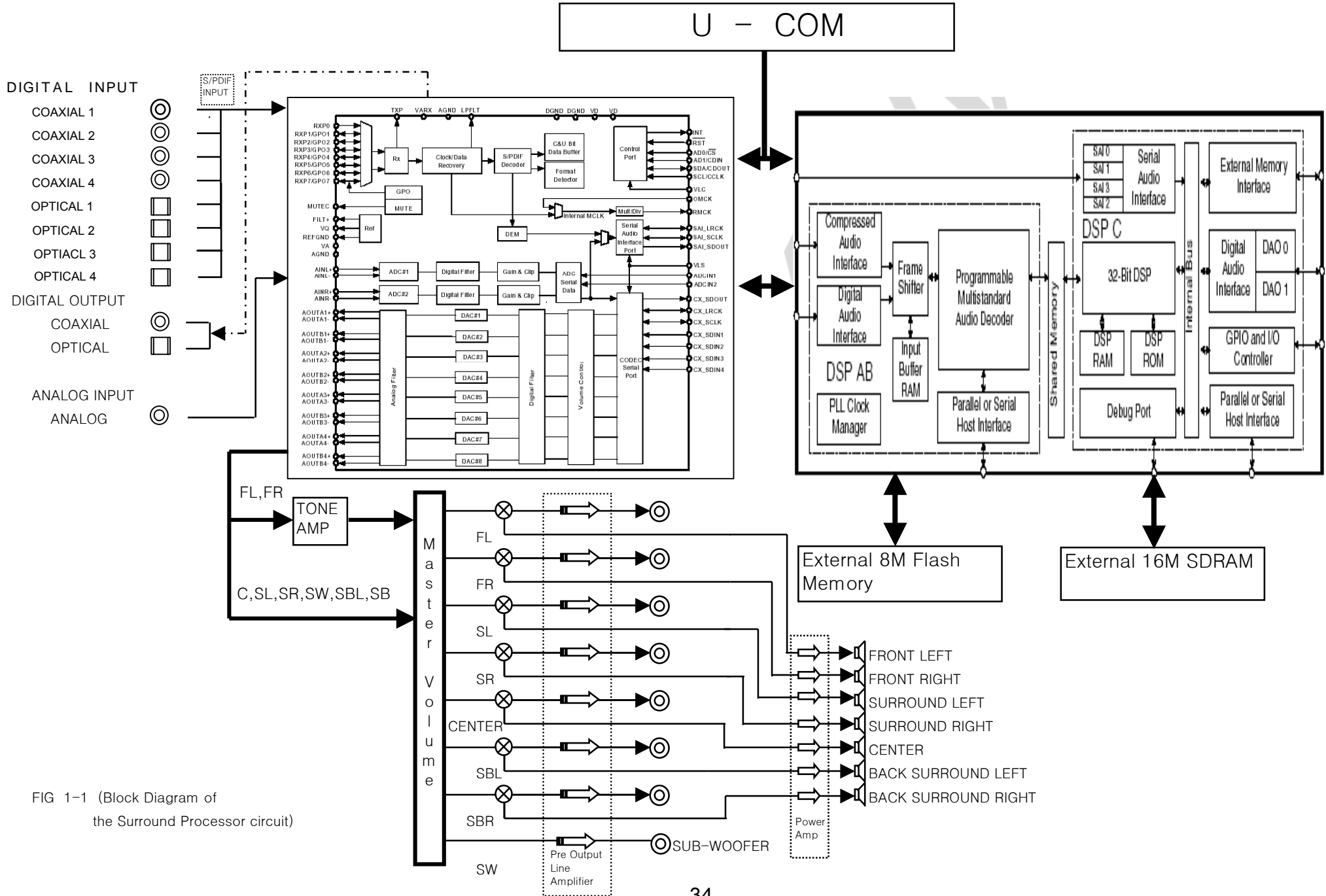
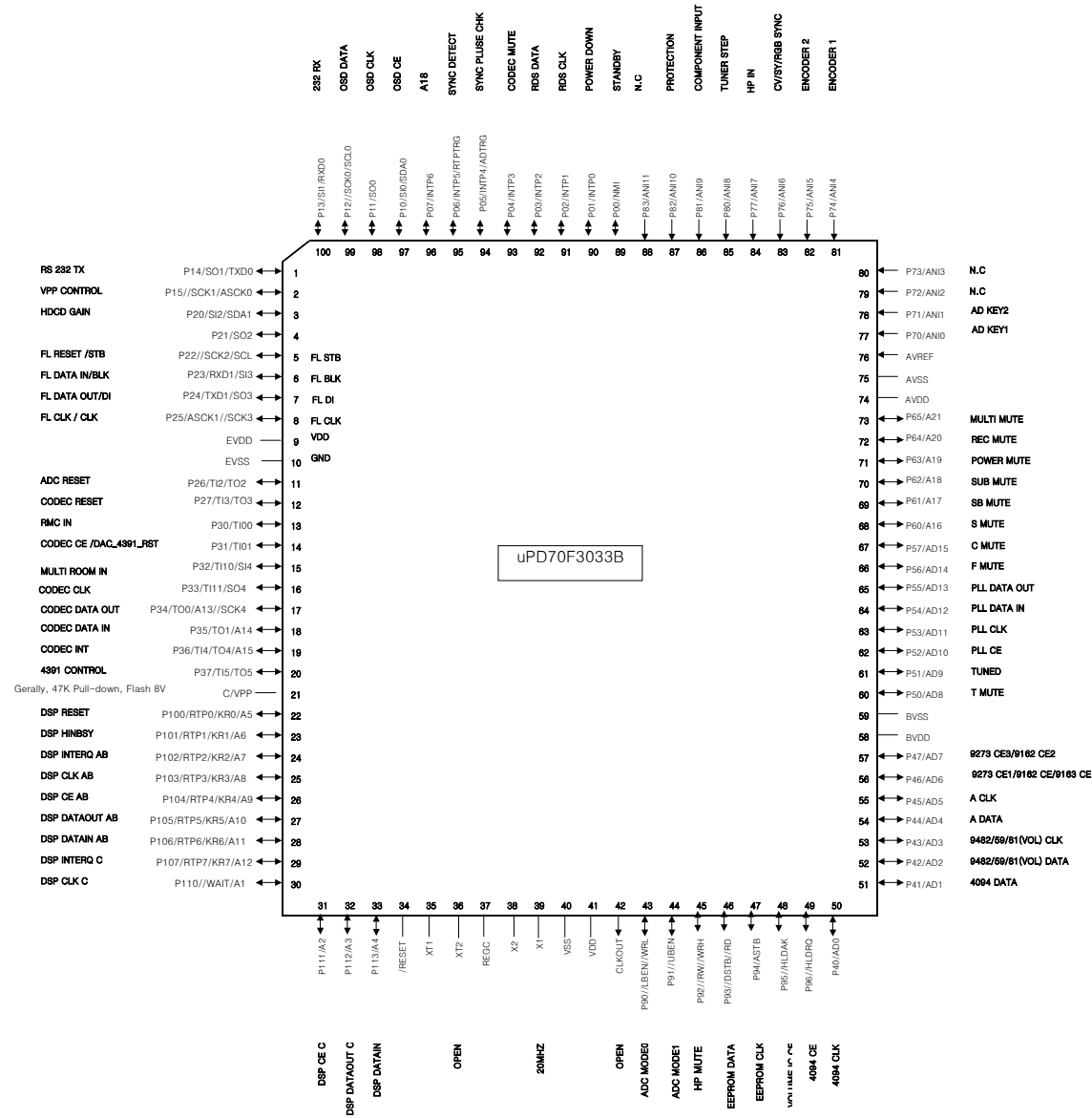

FIG 1-1 (Block Diagram of the Surround Processor circuit)

Upd70F3033BGF-3BA PORT DEFINE FOR AVR7300



## uPD70F3033B (V850/SB1) PORT ASSIGNMENT

PIN	V850 NAME	RECEIVER NAME	IN/OUT	Function And Description
1	P14/SO1/TXD0	RS-232 TX	TX	For CPU FLASH UPGRADE UART TX PORT
2	P15/SCK1/ASCK0	VPP_CONTROL	OUT	For Flash Upgrade VPP Control Pin
3	P20/SI2/SDA1	HDCD GAIN	OUT	HDCD GAIN
4	P21/SO2	N.C	OUT	OPEN
5	P22/SCK2/SCL1	FIP RST / FL STB	OUT	FIP DRIVER IC RESET / FL STROBE
6	P23/RXD1/SI3	FIP SI / FL BLK	SI	FIP DRIVER IC DATA IN / FL BLANK
7	P24/TXD1/SO3	FIP SO / FL DI	SO	FIP DRIVER IC DATA OUT / FL DI
8	P25/ASCK1/SCK3	FIP CLK / FL CLK	SCK	FIP DRIVER IC CLOCK OUT (NEC CPU가 MASTER) / FL CLK
9	EVDD	EVDD	POWER	Connected VDD
10	EVSS	EVSS	POWER	Connected GND
11	P26/TI2/TO2	ADC RESET	OUT	ADC RESET(DSP)
12	P27/TI3/TO3	CODEC_RESET	OUT	CODEC RESET(DSP)/DAC RESET
13	P30/TI00	RMC_IN	CAPTURE	REMOCON IN
14	P31/TI01	CODEC_CE	OUT	CODEC CHIP ENABLE(DSP)/DAC_4391_RST
15	P32/T110/S14	RMC_MULTI	CAPTURE	MULTI ROOM REMOCON
16	P33/TI11/SO4	CODEC_CLK	OUT	CODEC CLK(DSP)
17	P34/TO0/SCK4	CODEC_DATA_OUT	OUT	CODEC DATA_OUT(DSP)
18	P35/TO1	CODEC_DATA_IN	IN	CODEC DSP_IN(DSP)
19	P36/TI4/TO4	CODEC_INT	IN	CODEC INT(DSP)
20	P37/TI5/TO5	4391 CONTROL	OUT	4391 CONTROL
21	IC/VPP	VPP	IN	Normally, Opetation 47K Pull_Down, FLASH WRITE 8V
22	P100/RTP0/KR0	DSP_RESET	OUT	CS49400 RESET(DSP)
23	P101/RTP1/KR1	DSP_HINBSY	IN	CS49400 HINBSY(DSP)
24	P102/RTP2/KR2	DSP_INTERQ_AB	IN	CS49400 INTERQ_AB(DSP)
25	P103/RTP3/KR3	DSP_CLK_AB	OUT	CS49400 CLK AB
26	P104/RTP4/KR4	DSP_CE_AB	OUT	CS49400 CE AB
27	P105/RTP5/KR5	DSP_DATA_OUT_AB	OUT	CS49400 DATA OUT(DSP)
28	P106/RTP6/KR6	DSP_DATA_IN_AB	IN/OUT	CS49400 DATA IN(DSP)
29	P107/RTP7/KR7	DSP_INTERQ_C	IN	CS49400 INTERQ C(DSP)
30	P110/WAIT	DSP_CLK_C	OUT	CS49400 CLK C(DSP)
31	P111	DSP_CE_C	OUT	CS49400 CE C(DSP)
32	P112	DSP_DATA_OUT_C	OUT	CS49400 DATA OUT C(DSP)
33	P113	DSP_DATA_IN_C	IN/OUT	CS49400 DATA IN C(DSP)



34	/RESET	RESET	IN	LOW ACTIVE
35	XT1	N.C	IN	Pull_Down
36	XT2	N.C	OUT	OPEN
37	REGC	REGC	POWER	Connect VDD
38	X2	Fx_OUT	OUT	Connected 20.00MHz RESONATOR
39	X1	Fx_IN	IN	Connected 20.00MHz RESONATOR
40	VSS	VSS	POWER	Connected GND
41	VDD	VDD	POWER	Connected VDD
42	CLKOUT	N.C	OUT	OPEN (STOP MODE : LOW)
43	P90/LBEN/WRL	ADC MODE 0	OUT	ADC MODE 0(DSP)
44	P91/UBEN	ADC MODE 1	OUT	ADC MODE 1(DSP)
45	P92/RW/WRH	HP MUTE	OUT	HEADPHONE MUTE
46	P93/DSTB/RD	EEPROM DATA	IN/OUT	EEPROM DATA
47	P94/ASTB	EEPROM CLK	OUT	EEPROM CLK
48	P95/HLDAK	VOL IC CE	OUT	TC9481CE
49	P96/HLDRQ	4094 CE	OUT	4094 CHIP ENABLE
50	P40	4094 CLK	OUT	4094 CLK
51	P41	4094 DATA	OUT	4094 DATA
52	P42	9482/59/81 DATA	OUT	9482/59/81 IC DATA
53	P43	9482/59/81 CLK	OUT	9482/59/81 IC CLK
54	P44	A DATA	OUT	9273, 9162 , 9163 IC DATA
55	P45	A CLK	OUT	9481,9273,9162,9163 IC CLK
56	P46	9273 CE1	OUT	9273, 9162, 9163 CHIP ENABLE
57	P47	9273_CE3	OUT	9273, 9162 CHIP ENABLE
58	BVDD	BVDD	POWER	Connected VDD
59	BVSS	BVSS	POWER	Connected GND
60	P50	T_MUTE	OUT	TUNER MUTE OUT
61	P51	TUNED	IN	TUNED CHECK IN
62	P52	PLL_CE	OUT	TUNER PLL IC(LC72131) CHIP ENABLE
63	P53	PLL_CLK/T_CLK	OUT	TUNER PLL IC(LC72131) CLOCK
64	P54	T_DATA IN	IN	TUNER PLL IC(LC72131) DATA IN / STEREO CHECK
65	P55	T_DATA OUT	OUT	TUNER PLL IC(LC72131) DATA OUT
66	P56	FRONT MUTE	OUT	FRONT-CHANNEL MUTE
67	P57	CEN MUTE	OUT	CENTER-CHANNEL MUTE
68	P60	SURR MUTE	OUT	SURROUND-CHANNEL MUTE
69	P61	SB MUTE	OUT	SURR BACK-CHANNEL MUTE
70	P62	SUB MUTE	OUT	SUB WOOFER MUTE

71	P63	P MUTE	OUT	POWER MUTE
72	P64	RECMUTE	OUT	REC MUTE
74	AVDD	AVDD	POWER	Connected VDD
75	AVSS	AVSS	POWER	Connected GND
76	AVREF	AVREF	POWER	Vad
77	P70/ANI0	AD KEY1	ADIN	A/D KEY INPUT1
78	P71/ANI1	AD KEY2	ADIN	A/D KEY INPUT2
79	P72/ANI2	N.C	ADIN	Connected Register with VDD
80	P73/ANI3	N.C	ADIN	Connected Register with VDD
81	P74/ANI4	ENCODE1	IN	VOLUME ENCODER INPUT 1
82	P75/ANI5	ENCODE2	IN	VOLUME ENCODER INPUT 2
83	P76/ANI6	CV/SY/RGB SYNC	ADIN	CV/SY/RGB SYNC DETECT (A Comment 1)
84	P77/ANI7	HP_IN	IN	HEADPHONE INPUT
85	P80/ANI8	TUNER STEP	IN	TUNER OPTION L : USA H : EU
86	P81/ANI9	COMPONENT INPUT	IN	COMPONENT INPUT HD/SD CHECK
87	P82/ANI10	PROTECTION	IN	PROTECTION IN
88	P83/ANI11	N.C	IN	Connected Register with GND
89	P00/NMI	STANDBY	OUT	MAIN POWER ON/OFF
90	P01/INTP0	POWER DOWN	INTP0	POWER DOWN CHECK & WAKE UP : RISING EDGE
91	P02/INTP1	RDS_CLOCK	INTP1	RDS_CLOCK *EU ONLY
92	P03/INTP2	RDS_DATA	IN	RDS_DATA *EU ONLY
93	P04/INTP3	CODEC MUTE	OUT	CODEC MUTE
94	P05/INTP4/ADTRG	NT/PAL CHECK	IN	SYNC PLUSE CHECK(OSD IC 7PIN)
95	P06/INTP5/RTPTRG	SYNC DETECT	IN	SYNC CHECK(OSD IC 29PIN)
96	P07/INTP6	A18	OUT	AT49LV8192A PIN A18
97	P10/SI0	OSD CE	OUT	OSD CHIP ENABLE
98	P11/SO0	OSD CLK	OUT	OSD CLK
99	P12/SCK0	OSD DATA	OUT	OSD DATA
100	P13/SI1/RXD0	RS-232 RX	RX	For CPU FLASH UPGRADE UART RX PORT

A Comment 1) CPU PIN83 is A/D(Analog to Digital) port

INPUT SOURCE			VOLTAGE
COMPOSITE	SUPER	COMPONENT	
NO	NO	NO	5V
YES	NO	NO	3V
NO	YES	NO	3.6V
NO	NO	YES	1.9V
YES	YES	NO	2.4V
YES	NO	YES	0.7V
NO	YES	YES	1.3V
YES	YES	YES	0.2V

2. CS49400 DSPAB

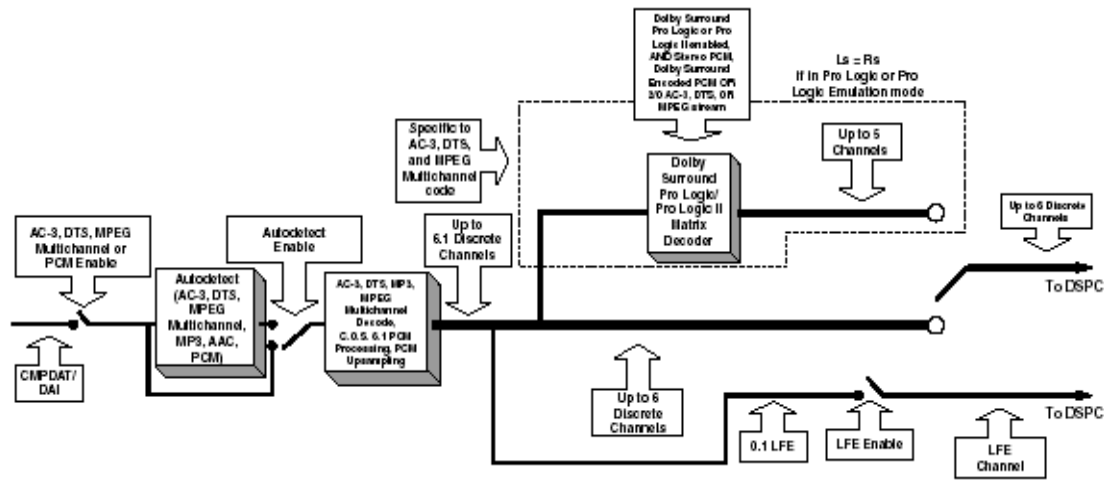

FIG 1-2 CS49400 Front-End Decoder

3. PCM

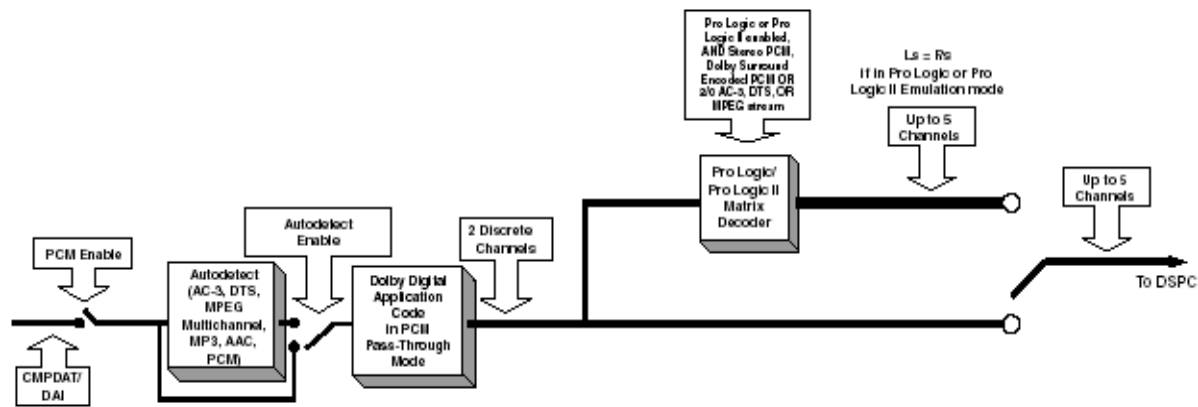

FIG 1-3 Dolby Digital Block Diagram, Configured for PCM Pass-Through

4. DOLBY DIGITAL

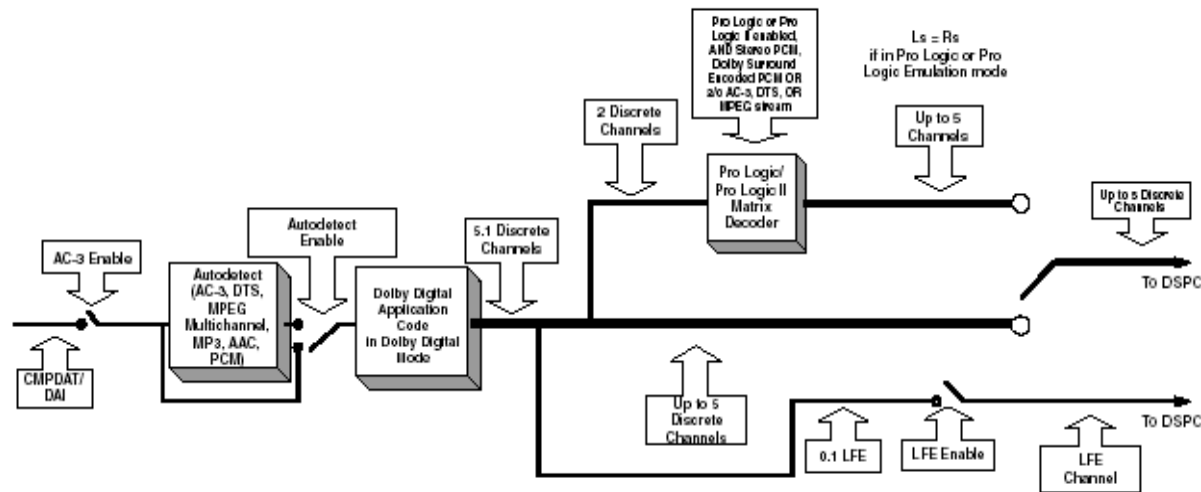

FIG 1-4 Dolby Digital Block Diagram, Configured for Dolby Digital (AC-3) Decoding

5. PRO LOGICII SURROUND

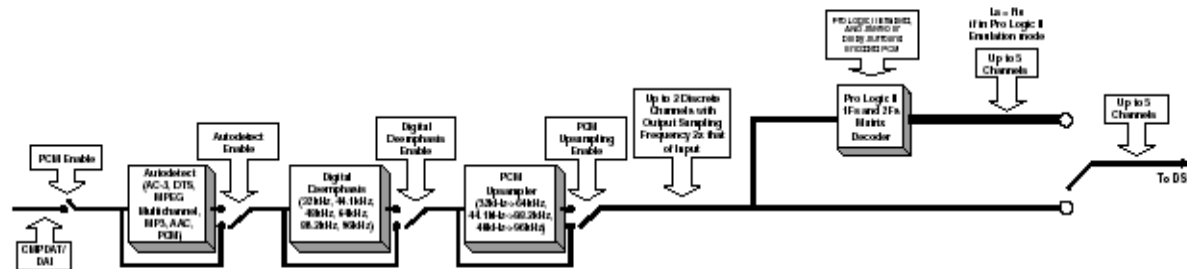

FIG 1-5 Dolby Surround Pro Logic II Surround 2Fs Decoder Block Diagram

6.DTS

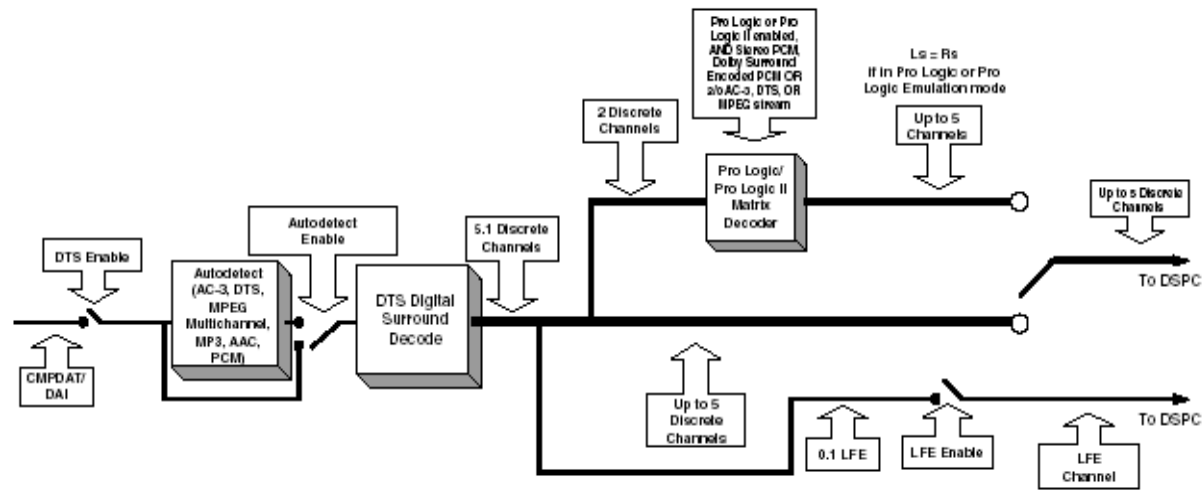

FIG 1-6 . DTS Block Diagram

7.DTS 96/24

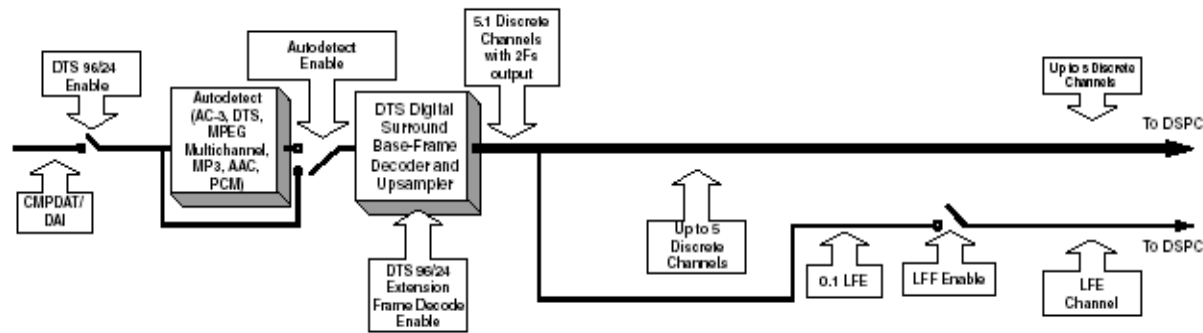

FIG 1-7 . DTS 96/24 Block Diagram

8.MP3

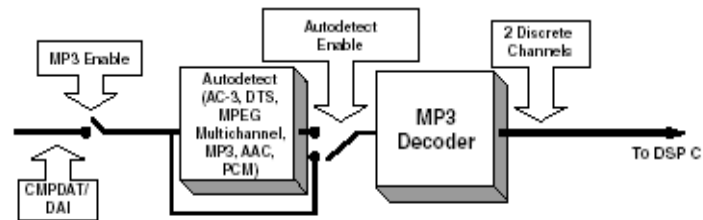

FIG 1-8 . MP3 Block Diagram

9.PCM UPSAMPLING

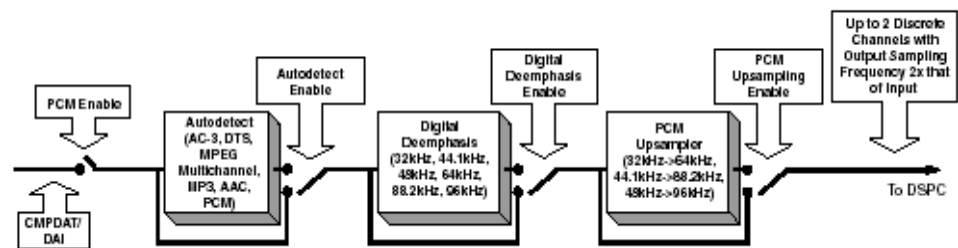
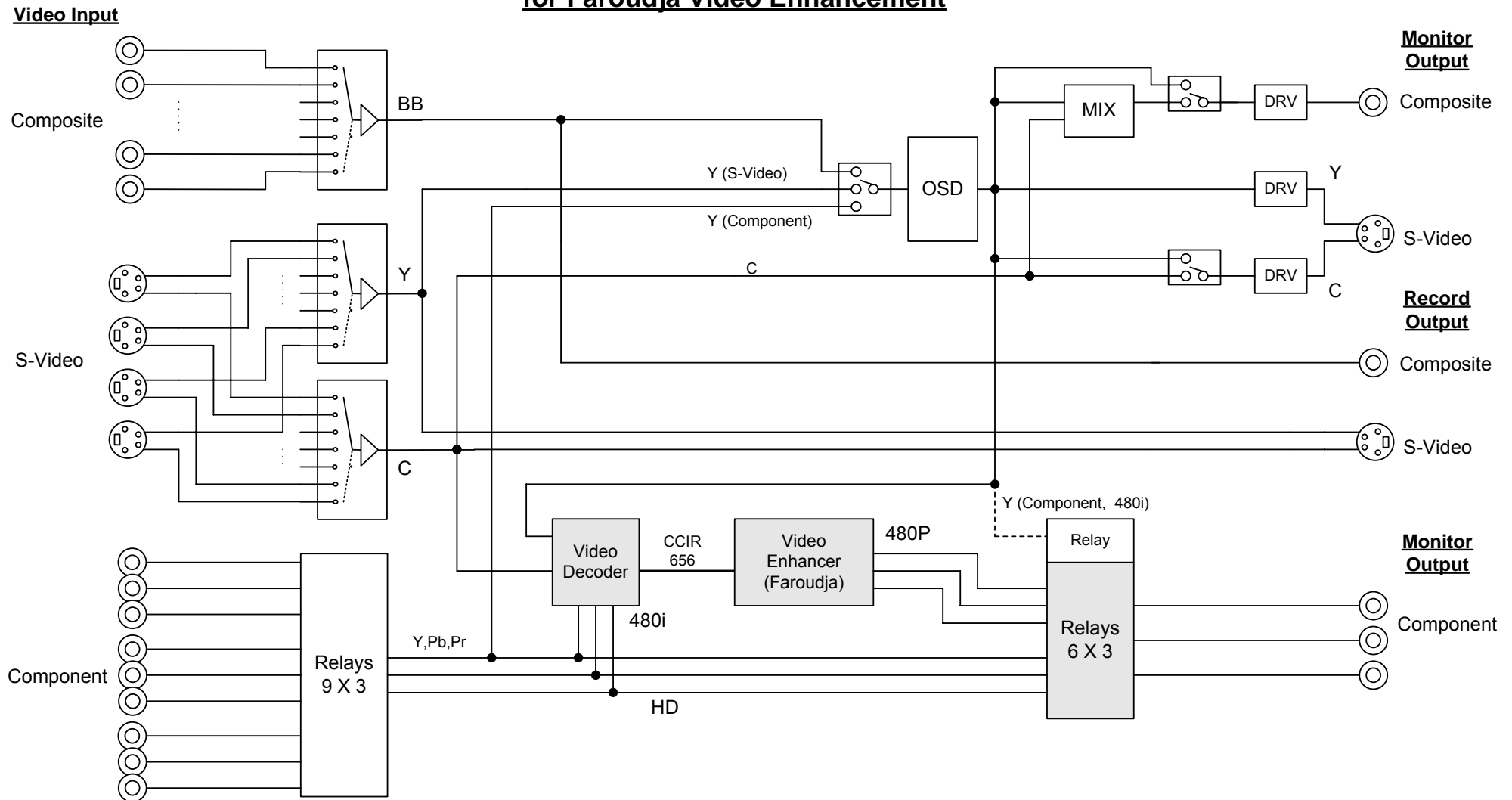

FIG 1-9 . PCM Pass-Through/Upsampler Block Diagram

### AVR7300 Video Board Block Diagram for Faroudja Video Enhancement



1. S-Video, composite outputs are the same as old AVRs.
2. Video enhancement for composite, S-video, 480i component inputs
3. **Only 480P component output**
4. OSD on component output (480P) for composite, S-video, 480i component inputs
5. No OSD on HD component output

G.S.Rho  
Jul/16/2003



## AVR7300 OFFSET ADJUSTMENT & IDLE CURRENT ADJUSTMENT(MP stage)

### 1 DC Offset - Adjustment

\* Function : 8CH DIRECT INPUT

Volume level : minimum

Test position : Speaker out terminal (between "+" and "-")->speaker jack

: no load

Adjustment:

a. Turn power ON

b. Adjust to chart below.

Channel	Check point	Adjustment position	Adjustment Limit	Note
FRONT L CH	FL SPEAKER	VR11(3channel AMP)	0±10mV	FL
REAR L CH	SL SPEAKER	VR21(3channel AMP)	0±10mV	SL
SURRBACK L CH	SL SPEAKER	VR31(3channel AMP)	0±10mV	SBL
REAR R CH	SR SPEAKER	VR41(4channel AMP)	0±10mV	SR
SURRBACK R CH	SBR SPEAKER	VR51(4channel AMP)	0±10mV	SBR
FRONT R CH	FR SPEAKER	VR61(4channel AMP)	0±10mV	FL
CENTER CH	CTR SPEAKER	VR71(4channel AMP)	0±10mV	CT

c. After 5 Min. check again at same figure.

### 2 Idle - Adjustment

\* Function : 8CH DIRECT INPUT

Volume level : minimum

Test position : refer to chart below

Adjustment:

a. Turn power ON, adjust to about 6.0~7.0mV.

Channel	Check point	Adjustment position	Adjustment Limit	Note
FRONT L CH	P101(R172)	VR12 (3channel AMP)	12.0mV~13.0mV	FL
REAR L CH	P201(R272)	VR22 (3channel AMP)	12.0mV~13.0mV	SL
SURRBACK L CH	P301(R372)	VR32 (3channel AMP)	12.0mV~13.0mV	SBL
REAR R CH	P401(R472)	VR42 (4channel AMP)	12.0mV~13.0mV	SR
SURRBACK R CH	P501(R572)	VR52 (4channel AMP)	12.0mV~13.0mV	SBR
FRONT R CH	P601(R672)	VR62 (4channel AMP)	12.0mV~13.0mV	FL
CENTER CH	P701(R772)	VR72 (4channel AMP)	12.0mV~13.0mV	CT

c. After 5 Min. Adjust again to the same figure

### 3 Adjustment Position

FL Offset Adj      FL Idle Adj

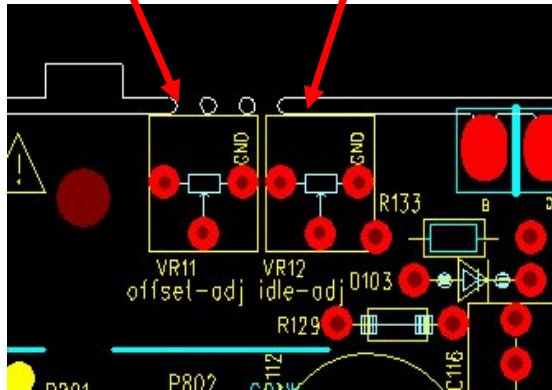

SL Offset Adj      SL Idle Adj

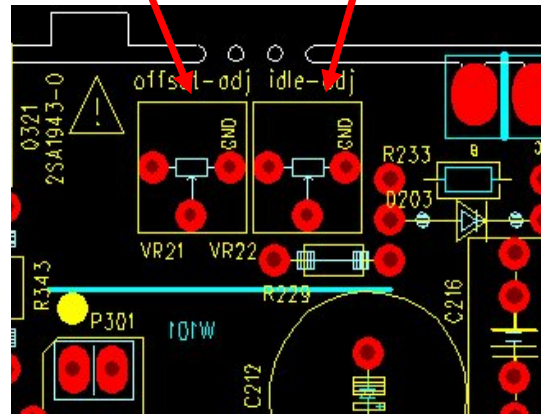

SBL Idle Adj      SBL Idle Adj

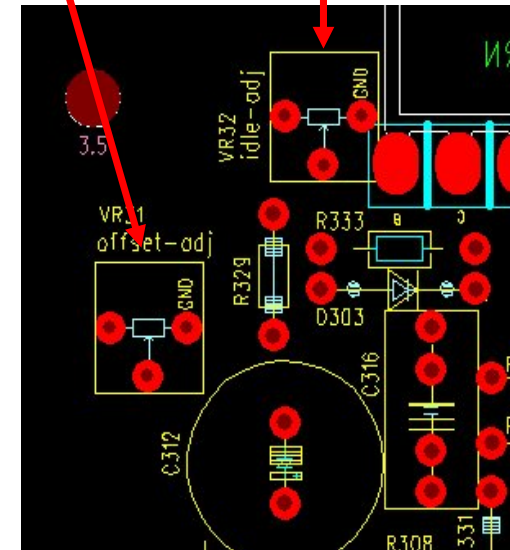

SR Offset Adj      SR Idle Adj

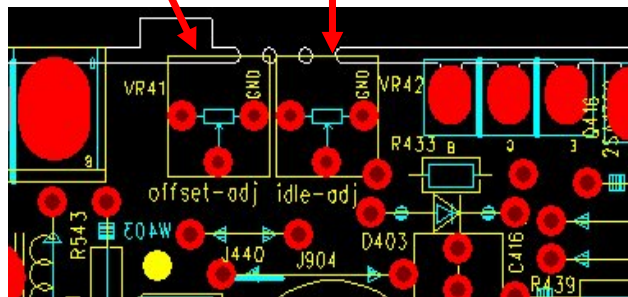

SBR Offset Adj      SBR Idle Adj

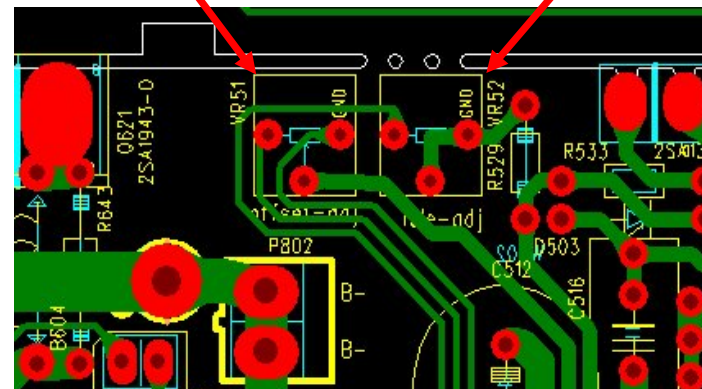

FR Offset Adj      FR Idle Adj

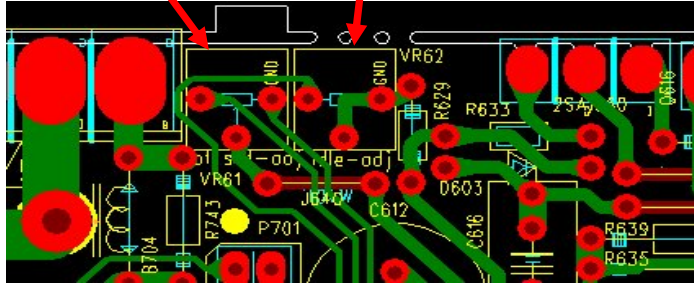

CT Offset Adj      CT Idle Adj

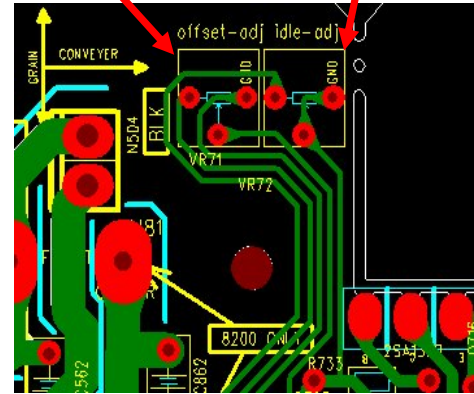

4 Check Position

FL Idle Check Position

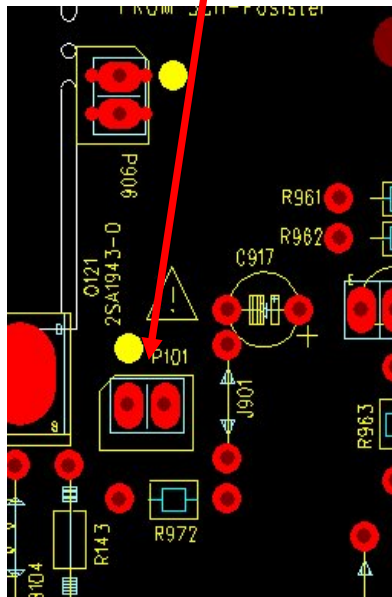

SL Idle Check Position

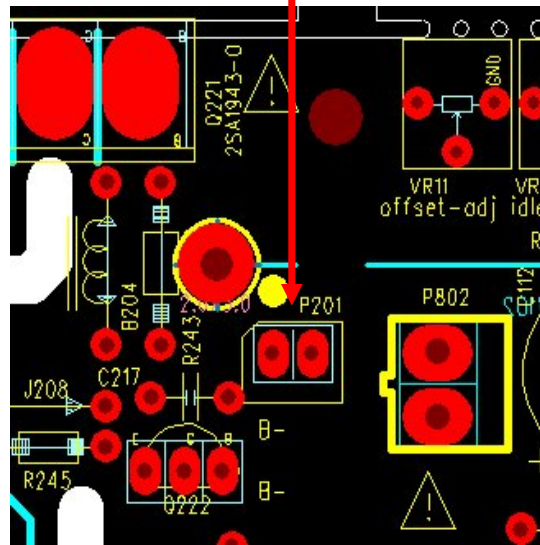

SBL Idle Check Position

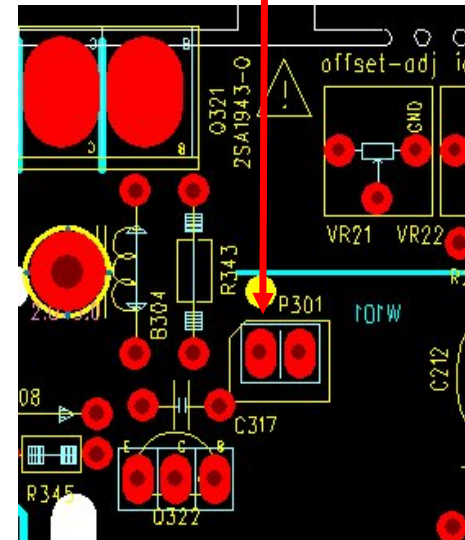

SR Idle Check Position

SBR Idle Check Position

FR Idle Check Position

CT Idle Check Position

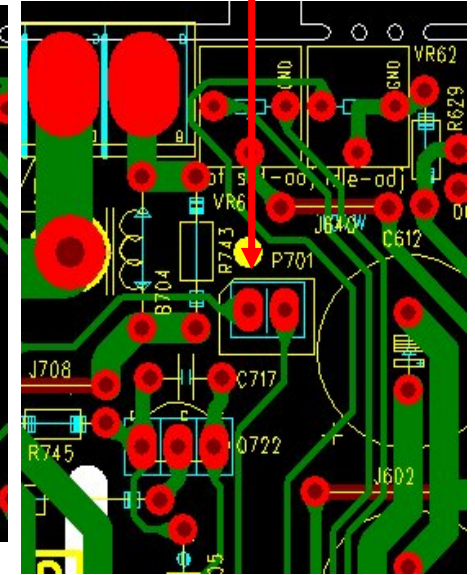
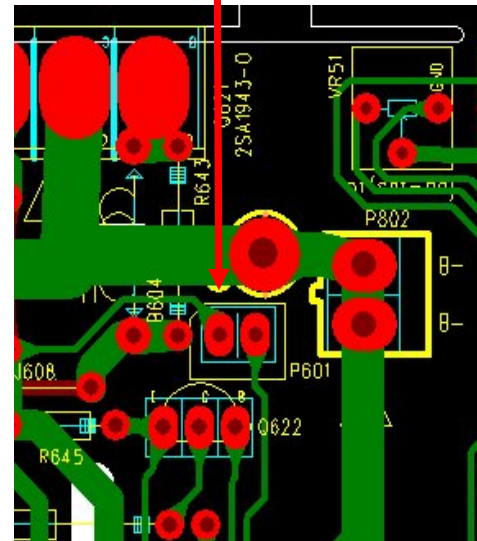
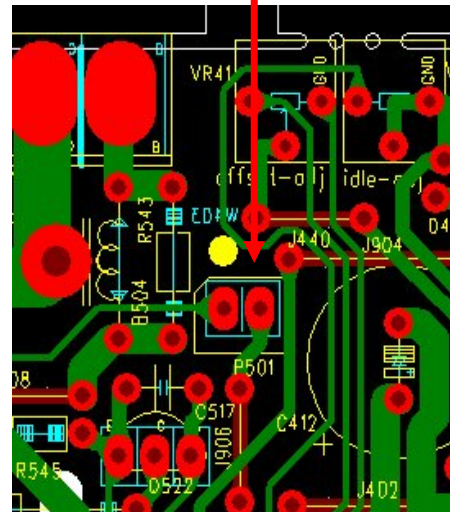
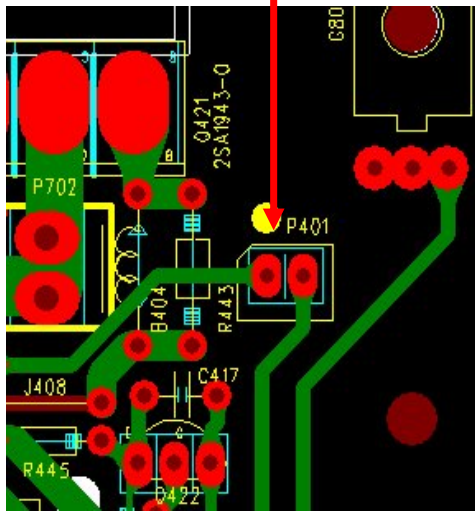



# harman/kardon

# Service Bulletin

Service bulletin # HK2005-01 January 2005

Warranty labor rate: MINOR repair

To: All harman/kardon Service Centers

Model: AVR7300

Subject: A-BUS Output too High

**In the event you receive an AVR7300 with the complaint: " There is distortion when using the A-BUS connection and a harman/kardon AB-1", perform the following modification:**

Synopsis: Change two resistors in the AVR7300.

The actual symptom is that the AB-1 is not able to totally reduce the volume down even at the minimum position on the level control, so there is distortion, or low level audible bleed-through in Zone 2

- 1) Remove the top cover (18) Black & Plated Phillips screws at the sides and rear of the unit.
- 2) Remove the Tuner Module from the rear panel, two screws. It does not have to be disconnected.
- 3) Removal of the DSP PCB: there are seven screws on the rear panel; four plated screws that attach the PCB, six molex and ribbon connectors, and three connector PCB's must be pushed away from the DSP connectors. Remove the DSP board from the unit.
- 4) Removal of the Processor PCB: there are six screws on the rear panel; four standoff's that attach the PCB, eight molex connectors and three connector PCB's must be pushed away from the Processor connectors. Remove the Processor board.
- 5) Locate the two 1KΩ 1/16W SMD resistors R249 and R205 on the bottom of the Processor board; replace both with 2.7KΩ components, h/k part# RS3AD0272NA-0.
- 6) Replace all PCB's, connectors, standoffs and screws in reverse order.
- 7) Test the unit (with an AB-1).

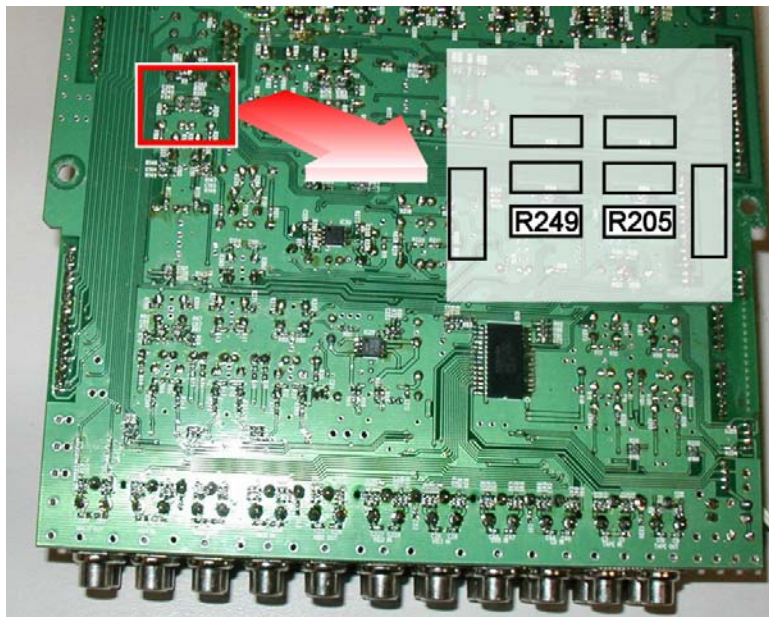

MODEL	SERIAL NUMBER	STATUS	ACTION
AVR7300 (120v)	TF0003-01000 to TF0003-02440	Distortion caused by too high output from A-BUS connection	Change R205, R249 from 1kΩ to 2.7kΩ
AVR7300 (120v)	TF0003-02441 and above	Modified by Factory	None Required
AVR7300 (230v)	TF0010-01001 and above	Modified by Factory	None Required

**harman/kardon****TECH TIPS****Troubleshooting tips and solutions to common service problems**

For models:

TIP# HKTT2003-01 Rev3

AVR7000/7200/7300/8000  
 AVR100/200/300/500  
 AVR110/210/310/510  
 AVR120/220/320/520  
 AVR125/225/325/525  
 AVR130/230/330/430/630  
 AVR135/235/335/435/635

AVR10  
 DPR1001  
 DPR1005  
 DPR2005  
 HK3370/3470/3375/3475  
 HK3250

**Subject:** Backup Memory on AVR/DPR/HK series receivers

**In the event of the complaint: “the receiver is losing its memory (any programmed system settings) when the unit is turned off, or after the unit is unplugged (briefly\*)”:**

Check and replace:

Model	Designator	Location	Description	Part number
AVR10	C712 D709	Front PCB	0.047 Farad 5.5v capacitor and 1N4148 diode	#3439247315 #2058322101
AVR7000	C730	Front PCB	0.047 Farad 5.5v capacitor	# 55134360 or # J3432147324X
AVR7200	C106	Front PCB	0.047 Farad 5.5v capacitor	# 55134360
AVR7300	C657	DSP PCB	0.047 Farad 5.5v capacitor	# H01-CEZXA0479MN-5
AVR8000	C726	Front PCB	0.047 Farad 5.5v capacitor	# 55230310NR or # 55134360
AVR100/200	C412	Front PCB	0.047 Farad 5.5v capacitor	# CEGT-B473J-0J0
AVR300	C906	Front PCB	0.1Farad 5.5v capacitor	# J4433210421X or # P10791-ND
AVR500	C906	Front PCB	0.1Farad 5.5v capacitor	# J4433210421X or # P10791-ND
AVR110/210/310/510 AVR120/220/320/520	C216	Front PCB	0.047 Farad 5.5v capacitor	# 55134360
AVR125/225	C734,C885	Front PCB	two 0.1F capacitors in parallel	# BCESOHD104
AVR325/525	C106	Front PCB	0.047 Farad 5.5v capacitor	# 55134360
AVR130/230/330	BAT1	Front PCB	3.6v Battery	# HABGP40BVH3A3H
AVR135/235/335	BAT1	Front PCB	3.6v Battery	# HGP15BNH3A3H
AVR430/630	C657	DSP PCB	0.047 Farad 5.5v capacitor	# CEZXA0479MN-5
AVR435/635	C657	DSP PCB	0.047 Farad 5.5v capacitor	# CEZXA0479MN-5
DPR1001	BC601	Main PCB	0.1Farad 5.5v capacitor	# CEGT-B104J-0J0
DPR1005/2005	C437	Processor PCB	0.047 Farad 5.5v capacitor	# CEZXA0479MN-5
HK3370/3470	C301	Front PCB	0.1Farad 5.5v capacitor	# CEGT-B104J-0J0
HK3375/3475	C301	Front PCB	0.1Farad 5.5v capacitor	# CEGT-B104J-0J0
HK3250	C712 D709	Front PCB	0.047 Farad 5.5v capacitor and 1N4148 diode	#3439247315 #2058322101

\* After approximately two weeks of being disconnected from AC supply, even a normally functioning receiver may lose any programmed settings and switch to default settings.

AVR7300 Electrical Parts List		
Ref Designator	Part Number	Description
<b>MAIN PCB</b>		
<i>Capacitors</i>		
C220 223 226	CEHDC0108NN-3	CE 1MIOF +20% 6.3V 8X11.5 85C ELITE
C339 344 369	CEHEC01075E-8	CE 100U0F +20% 10.0V 5X11 85C P5MM
C1 3 311 313 320 321 324	CEHEC02275E-9	CE 220UF +20% 10.0V D6.3XL11 P5MM 85C
C2 5 7 305 307 309 314 316 318 357 361 363	CEHFC01075E-1	CE 100UF +20% 16.0V D6.3XL11 P5MM 85C
C364	CEHFC04765E-3	CE47UF +20% 16.0V D5XL11 P5MM 85C
C213 216 219 222 225 228 231 232 341 352	CEHIC01055E-6	CE 1UF +20% 50V D5XL11 P5MM 85C
C9 214 217 229 370	CEHIC01065E-4	CE 10U0F +20% 50.0V 85C P5MM 5X11
C10 368	CEHIC02255E-7	CE 2U2F +20% 50V D5XL11 P5MM 85C
C347	CEHIC0474NN-9	CE 470N0F +20% 50.0V 85C 5X11 ELITE
C243	CEMFA02285E-5	CE 2200UF 16V M 12.5X20 P5MM
C237	CEMFC03375E-A	CE 330UF 16V M 8X11.5 P5MM 85C
C312 322 323 330	H01-CEMFC0106AH-7	CAP ELEC 10UF 16V M 5X11 P5MM SHL
C15 51 52 53	CEMFC0226NN-9	CAP ELEC 22UF 16V M ELITE
C233 235	CEMGC0227NN-0	CAP ELEC 220UF 25V M 8X11.5 ELITE
C338	CPIIC0223NN-4	CPF 22N0F +10% 50.0V
C201 202 203 204 205 206 207 208 209	CPIKC0473NN-0	CPF 47N0F +10% 100.0V
C342	CPIIC0682NN-5	CPF 6N8F +10% 50.0V
C348 349 350 351	CCJIC0390NE-2	CC 39P0F +5% -5% 50.0V NP0
C261	H01-CEMIC0105AH-7	CE 1UF 50V M 5X11 SHL
C358	H01-CEMIC0334AH-4	CAP ELEC 0.33UF M 5X11 SHL 50V SAMYOUNG
C242	H01-CEMFA0109AH-6	CE MHA 10MIOF 16V M 16*35.5 SAMYOUNG
C240 241	H01-CEMHA0828AH-8	CAP ELEC 8200UF 35V M 22X45 AHS SAMYOUNG
C244	H01-CEMIA0478AH-7	CAP ELEC 4700UF 50V M 22X45 DL SAMYOUNG
C238 239	H01-CEMKA0228AH-0	CAP ELEC 2200UF 100V M 22X45 AHS SAMYOUNG
C251 255 281 282 283 284 285 286 287 288 290 291 292 293 294 295 296 298 301 302 303 353 354 355	CZJII0101BE-2	CCCFMIC 100P0F +5% -5% 50.0V NP0 0603
C340	CZJII0270BE-1	CCCFMIC 27P0F +5% -5% 50.0V NP0 0603
C337	CZJII0330BE-9	CCCFMIC 33P0F +5% -5% 50.0V NP0 0603
C11 335 345	CZKII0103BC-5	CAP CHIP 10N0F +10% -10% 50.0V X7R 0603
C92	CZKII0153BC-1	CAP CHIP 15N0F +10% -10% 50.0V X7R 0603
C91	CZKII0822BC-6	CAP CHIP 8N2F +10% -10% 50.0V X7R 0603
C6 215 218 224 227 230 272 306 308 310 315 317 319 346 362	CZZFI0104BF-8	CAP CHIP 100N0F +80% -20% 16.0V Y5V 0603
C262	CZDII0100BE-8	CAP CHIP 10PF 50V CH D NP0 0603 +0.25P
C325 326 327	CZJII0101BE-2	CCCFMIC 100P0F +5% -5% 50.0V NP0 0603
C343	CZKII0103BC-5	CAP CHIP 10N0F +10% -10% 50.0V X7R 0603
C367	CZKII0223BC-6	CAP CHIP 22N0F +10% -10% 50.0V X7R 0603
C8 221 234 236 328	CZZFI0104BF-8	CAP CHIP 100N0F +80% -20% 16.0V Y5V 0603
C210 211 212	CFIOC0104NN-5	CPM 100N0F +10% 250.0V
<i>Semiconductors</i>		
Q213 214	H01-TR2SA933ANW-2	TR-SLPLF 2SA933ASR P -3.0A -20V
Q211 7	H01-TR2SC1740NW-9	TR-SLPLF 2SC1740S R N 150MIOA 50V
Q6	H01-TRKTC3198NA-3	TR-SLPLF KTC3198BL N 150MIOA
Q241	H01-TRKTD1302NA-0	TR-SLPLF KTD1302 B N 300MIOA 20V
D201 203 204	H01-DRBU604F0NA-9	DIODE BRIDGE BU6-04F FRONTIER
D202	H01-DRW204F00BA-A	DIODE BRIDGE W2-04F FRONTIER
IC214	H01-ICBA033T0I2-9	IC-REGPOFXD BA033T NORMAL
IC213 215	H01-ICKIA7805I2-7	IC-REGPOFXD KIA7805API NORMAL TO-220IS
IC207	H01-ICKIA7806I2-9	IC KIA7806AP VOLTAGE REGULATOR TO-220AB
IC211 212	H01-ICKIA7824I2-7	IC-REGPOFXD KIA7824API TO-220IS NORMAL
IC216	H01-ICKIA7905I2-5	IC-REGNEGFXD KIA7905PI NORMAL
IC217	H01-ICLM07815BD-0	IC-REGPOFXD KIA7815API NORMAL
IC218	H01-ICLM07915BD-9	IC-REGNEGFXD KIA7915API NORMAL TO-220AB
IC219 220	H01-ICPC17T10B1-2	IC PHOTOCOUPLER PC-17T1 DIP4 KODENSHI
D1 2 205 206 223 224 225 226	H01-DS0KDS160NB-4	D-SLP KDS160 85.0V 100MIOA

Ref Designator	Part Number	Description
<b>MAIN PCB</b>		
D5 6 7 219 220 3 4 231 232	H01-DS1S50094NB-A	D-SLP 1SS355 35.0V 225MIOA
Q4 215 216 222	H01-TRDTA114YNI-9	TR-SSD DTA114YKA P 10K0 OHM 47K0 OHM
Q1 2 201 202 203 204	H01-TRDTC114YNI-5	TR-SSD DTC114YKA N 10K0 OHM 47K0 OHM
Q5	H01-TR2SA1145NA-2	TR-SLPLF 2SA1145Y TO-92MOD P -50MIOA -150V
IC208	H01-ICBU4094BD3-2	IC CMOS BU4094BF SOP16
IC209	H01-ICLC74763I4-1	IC OSD LC74763M SOP30
IC2 201 202 203	H01-ICMM1510XDL-7	IC-VIDEO SW MM1510XNRE SOT-26A
IC1 204 205	H01-ICMM1501XDL-A	IC-VIDEO SW MM1501XNRE SOT-26B
IC206	H01-ICMM1511XDL-8	IC-VIDEO SW MM1511XNRE SOT-26B
Q212	H01-TRDTC114YNI-5	TR-SSD DTC114YKA N 10K0 OHM 47K0 OHM
Q3 221	H01-TRKTA1504ND-7	TRANSISTOR PNP KTA1504Y(S)SOT-23
D8 9	H01-DR1N04004NA-1	D-SR 1N4004 400.0V 1.0A
<i>Resistors</i>		
R18	RC3DI0220IN-3	RESISTOR CARBON FILM 22OHM 1/4W 5%
R13	RC3DI022AIN-2	RCF 2R2 OHM +5% 250MIOW
R201 202 204 207	H01-RM3GC047ACN-9	RESISTOR METAL OXIDE 4R7 +5% 2.0W
R208 209	H01-RM3HA056ADN-A	RESISTOR METAL OXIDE 5R6 3W 5% RW
R19	H01-RP3NA0101NZ-3	POS 100R0 OHM 16.0V RED
R12 278 281 282 283 284 285 286 287 288 291 292 293 294	RS3AD0101NA-5	RMGCFMIC 100R0 OHM +5% 62MI5W
R232	RS3AD0102NA-3	RMGCFMIC 1K0 OHM +5% 62MI5W
R9 10 11 14 220 223 225 271 272 273 274	RS3AD0103NA-1	RMGCFMIC 10K0 OHM +5% 62MI5W
R15 17	RS3AD0104NA-A	RMGCFMIC 100K0 OHM +5% 62MI5W
R250 251	RS3AD0105NA-8	RES CHIP 1M 1/16W +5% 0603
R248 249	RS3AD0121NA-A	RMGCFMIC 120R0 OHM +5% 62MI5W
R210 211	RS3AD0562NA-2	RMGCFMIC 5K6 OHM +5% 62MI5W
R261 265	RS3AD0392NA-1	RMGCFMIC 3K9 OHM +5% 62MI5W
R260 264	RS3AD0471NA-5	RMGCFMIC 470R0 OHM +5% 62MI5W
R266	RS3AD0473NA-1	RMGCFMIC 47K0 OHM +5% 62MI5W
R16	RS3AD0272NA-0	RMGCFMIC 2K7 OHM +5% 62MI5W
R221 222 224	RS1AD0750NA-6	RES CHIP 75OHM 1% 1/16W 0603
R212	RS3AD0822NA-2	RMGCFMIC 8K2 OHM +5% 62MI5W
R228 229 230 233 244 245 246 252	RS3AD0102NA-3	RMGCFMIC 1K0 OHM +5% 62MI5W
R20 235 243	RS3AD0103NA-1	RMGCFMIC 10K0 OHM +5% 62MI5W
R8	RS3AD0104NA-A	RMGCFMIC 100K0 OHM +5% 62MI5W
R234	RS3AD0121NA-A	RMGCFMIC 120R0 OHM +5% 62MI5W
R231	RS3AD0123NA-6	RMGCFMIC 12K0 OHM +5% 62MI5W
R241	RS3AD0124NA-4	RMGCFMIC 120K0 OHM +5% 62MI5W
R237	RS3AD0152NA-A	RMGCFMIC 1K5 OHM +5% 62MI5W
R239	RS3AD0154NA-6	RMGCFMIC 150K0 OHM +5% 62MI5W
R3	RS3AD0000NA-0	RMGCFMIC 0 OHM +0% 62MI5W
R304	RS3AD0222NA-4	RMGCFMIC 2K2 OHM +5% 62MI5W
R6	RS3AD0223NA-2	RMGCFMIC 22K0 OHM +5% 62MI5W
R240	RS3AD0224NA-0	RMGCFMIC 220K0 OHM +5% 62MI5W
R303	RS3AD0333NA-6	RMGCFMIC 33K0 OHM +5% 62MI5W
R7	RS3AD0392NA-1	RMGCFMIC 3K9 OHM +5% 62MI5W
R4	RS1AD0471NA-A	RESISTOR CHIP 470OHM 1/16W 1% 0603
R5	RS1AD4990NA-A	RES CHIP 499OHM 1/16W 1% 0603
R238	RS3AD0513NA-4	RMGCFMIC 51K0 OHM +5% 62MI5W
R236	RS3AD0682NA-3	RMGCFMIC 6K8 OHM +5% 62MI5W
R302	RS3AD0750NA-1	RMGCFMIC 75R0 OHM +5% 62MI5W
R1	RS3AD0820NA-6	RMGCFMIC 82R0 OHM +5% 62MI5W
<i>Miscellaneous</i>		
L212	H01-FY0100101N8-5	FILTER MPX 01011-101
JA203	SOMOD7400NN-6	JACK MODULAR 7400-621002
JA202	H01-SOR12BJ12NN-3	JACK RCA 12P BJ120154JN
JA201	H01-SORA11Y00NN-5	JACK RCA+S VIDEO C5016031DN
JA205	H01-SORA40RSANN-6	JACK RCA 4P JB040131ZN GN BN PP TA
JA206	H01-SORA40RSCNN-A	JACK RCA 4P JB040131QN WH BU RD GY
L204 207 208 209 210	H01-LAINB0470CR-2	LF 47U0H +10% 5.8 OHM 500MIOA



Ref Designator	Part Number	Description
<b>MAIN PCB</b>		
L213	H01-LAINB056ACR-0	LF 5U60H +10% 5.8 OHM 500MIOA
N203 204	H01-WG04SD82300-6	WIRE ASS'Y 2.5MM 4P 230MM UL1007#22 RED
N211	H01-WG15SB82800-0	WIRE ASS'Y 2.0MM 15P 280MM UL1007#26 RED
P212	H01-WH20SC00000-3	PIN HEADER 2.54MM 20P TPH03-115-20P
P211	H01-WH30SC00000-A	PIN HEADER 2.54MM 30P TPH03-115-30P
N3	H01-WN02SB00000-9	CONN 2.0MM 2 MA ST NAT GT201-2P-TS
N4	H01-WN03SB00000-6	CONN 2.0MM 3 MA ST NAT GT201-3P-TS
P201 202	H01-WN06SD100WH-8	CONN WAFER 2.5MM 6P 5267-06A WHT
R203 206	H01-RM3FC010ABN-8	RESISTOR METAL OXIDE 1 OHM 1W 5%
P205	H01-WN14SB100WH-1	CONN WAFER 2.0MM 14P 35336-1410 WHT
P203 208	H01-WN19SB00000-6	CONN 2.0MM 19 MA ST NAT MOLEX 35336-1910 0 0
JA204	H01-ZVD05FAN100-8	DC FAN TFD-4510L12B 45X45X10MM
Y201	H01-OSXBE14M3AU-7	CRYSTAL 14.31818MHz WOOIN
Y202	H01-OSXBE17M7AU-9	CRYSTAL 17.734475MHz WOOIN
RY1 2 203 204 205 206	H01-RLLO517811A-A	RELAY D3009(1-1462033-4)
G201	H01-ZNMSA4004SN-4	TERMLUG GND
W350	H01-WG01S011000-9	WIRE ASS'Y UL1007#16 STR 110MM 1P BLK TERMINAL
F200 201 202 203 204 205 206 207	H01-FURN2200006-6	FUSE T 2A 250V 7.6X8.6 SS-5 SAVE FUSETECH
<b>Processor PCB</b>		
<i>Capacitors</i>		
C176 177	CEHDC0108NN-3	CE 1MIOF +20% 6.3V 8X11.5 85C ELITE
C5 8 15 18 39 42 55 58 74 77 78 81 86 89 92 95 96 97 98 99 100 101 102 103 104 105 108 109 112 119 120 122 127 129 132 133 138 145 146 153 158 165 168 175 189 201 202 208 209 210 224 225 233	CEHFC04765E-3	CE47UF +20% 16.0V D5XL11 P5MM 85C
C221 222	CEHIC04755E-6	CE 4U7F +20% 50.0V 85C P5MM
C6 7 13 14 16 17 19 20 37 38 40 41 53 54 56 57 59 60 75 76 79 80 82 83 84 85 87 88 90 91 106 107 113 114 116 118 121 123 124 125 126 131 139 140 142 144 147 149 151 152 159 160 162 164 169 170 172 174 190 195 196 197 198 205 206 207	H01-CEMFC0106AH-7	CAP ELEC 10UF 16V M 5X11 P5MM SHL
C1 2 3 4 9 10 11 12 21 22 23 24 25 26 27 28 29 30 31 32 33 34 35 36 43 44 45 46 47 48 49 50 61 62 63 64 65 70 71 72 73 110 117 136 143 155 156 163 166 173 178 179 180 181 182 183 184 191 192 193 194 223 226 227 228 229	CZJII0101BE-2	CCCFMIC 100P0F +5% -5% 50.0V NP0 0603
C67 69 130 134 188 203 204 231 232	CZJII0330BE-9	CCCFMIC 33P0F +5% -5% 50.0V NP0 0603
C128 135	CZKII0821BC-8	CAP CHIP 820P0F +10% -10% 50.0V X7R 0603
C94 148	CZKII0222BC-8	CAP CHIP 2N2F +10% -10% 50.0V X7R 0603
C51 52 185 186 211 212 230	CZZFI0104BF-8	CAP CHIP 100N0F +80% -20% 16.0V Y5V 0603
C219 220	CZJII0150BE-0	CCCFMIC 15P0F +5% -5% 50.0V NP0 0603
C66 68 111 115 137 141 154 157 161 167 171 199 200	CZJII0330BE-9	CCCFMIC 33P0F +5% -5% 50.0V NP0 0603
C215 216 217 218	CZKII0103BC-5	CAP CHIP 10N0F +10% -10% 50.0V X7R 0603
C93 150	CZKII0222BC-8	CAP CHIP 2N2F +10% -10% 50.0V X7R 0603
C213 214	CZKII0682BC-7	CAP CHIP 6N8F 50V X7R K 0603
<i>Semiconductors</i>		
D6	H01-DZMTZJ5B6NB-5	DIODE ZENER MTZ J5.6B 5.6V 500MW DO-34
Q1 18 19 21	H01-TRKTD1302NA-0	TR-SLPLF KTD1302 B N 300MIOA 20V
Q2 5	H01-TRMPSA06NNA-4	TR-SLPLF MP5A06 N 500MIOA TO-92
Q4 6	H01-TRMPSA56YNA-5	TR-SLPLF MP5A56 Y P -500MIOA -300V
D1 2 3 4 5	H01-DS1S50094NB-A	D-SLP 1SS355 35.0V 225MIOA
IC29 30	H01-ICLM02068D2-A	IC-OPERAMP NJM2068M DUAL SOP8

Ref Designator	Part Number	Description
<b>Processor PCB</b>		
IC10	H01-ICTC9273NDA-0	IC-SWITCH TC9273F-004 SOP28 ANALOG SWITCH
Q54	H01-TRDTC114YNI-5	TR-SSD DTC114YKA N 10K0 OHM 47K0 OHM
Q24 26 27 28 29 30 31 33 36 38 39 40 42 44 45 46	H01-TRKTD1304ND-5	TR-SLPSWA KTD1304 N 20V 300MI0A SOT-23
D8 9 12 14 21 Q47	H01-DSUDZ09V1NB-7	D-ZENER UDZS 9.1B 9.1V 200MI0W
IC5 14	H01-ICKIC9162DA-5	IC-SWITCH KIC9162AF SOP28 ANALOG SWITCH
IC3	H01-ICKIC9163DA-7	IC-SWITCH KIC9163AF SOP28 ANALOG SWITCH
IC2 18	H01-ICKIC9459D5-8	IC-LOWFREQ KIC9459F SOP24 TONE/VOL/BAL/MUTE
IC1 4 7 8 9 11 12 13 15 16 17 20 21 22 23 24 25 26 27	H01-ICLM02068D2-A	IC-OPERAMP NJM2068M DUAL SOP8
IC19	H01-ICLMO9482DA-5	IC-LOWFREQ KIC9482F/TC9482F SOP28 TONE/VOL/BAL/MUTE
IC6	H01-ICTC9273NDA-0	IC-SWITCH TC9273F-004 SOP28 ANALOG SWITCH
IC28	H01-ICTC9481FDA-0	IC-LOWFREQ TC9481F SOP28 TONE
Q3 13 14 17 20 23 25 32 34 35 37 41 43 50 52	H01-TRDTA114YNI-9	TR-SSD DTA114YKA P 10K0 OHM 47K0 OHM
Q22	H01-TRDTC114YNI-5	TR-SSD DTC114YKA N 10K0 OHM 47K0 OHM
Q7 8 9 10 11 12 15 16 51 53 58 59	H01-TRKTD1304ND-5	TR-SLPSWA KTD1304 N 20V 300MI0A SOT-23
<i>Resistors</i>		
R329 334 800	RS3AD0000NA-0	RMGCFMIC 0 OHM +0% 62MI5W
R1 10 11 13 18 30 31 44 63 64 75 77 78 79 82 88 89 98 101 106 107 112 121 126 131 133 136 137 141 142 166 167 171 172 174 184 185 189 195 198 204 231 238 288	RS3AD0101NA-5	RMGCFMIC 100R0 OHM +5% 62MI5W
R61 71 72 80 81 91 92 93 94 95 96 138 139 140 143 144 145 150 151 152 153 154 155 168 169 170 205 221 229 247 249 254 256 264 269 277 279 286 293 301 303 310 315 316 324 325 326 343 344 345 346 347 348 349 350 378	RS3AD0102NA-3	RMGCFMIC 1K0 OHM +5% 62MI5W
R2 5 12 14 15 16 17 21 26 28 33 35 40 41 42 43 45 47 50 52 58 60 65 66 67 68 85 86 99 100 103 104 105 109 110 111 113 114 119 120 123 124 129 130 146 147 161 162 175 176 181 183 186 188 191 192 193 194 214 217 218 225 233 234 239 241 244 245 246 251 252 281 282 287 289 305 306 308 311 313	RS3AD0104NA-A	RMGCFMIC 100K0 OHM +5% 62MI5W
R134 163 164 165 196 203	RS3AD0123NA-6	RMGCFMIC 12K0 OHM +5% 62MI5W
R200 202 235 237	RS3AD0152NA-A	RMGCFMIC 1K5 OHM +5% 62MI5W
R132 255 263 270 278 294 302	RS3AD0202NA-A	RMGCFMIC 2K0 OHM +5% 62MI5W
R213 220 226 259 268 274 292 298 327 328 336 337 338 339	RS3AD0222NA-4	RMGCFMIC 2K2 OHM +5% 62MI5W
R20 56 62 74 115 116 117 118 190 332	RS3AD0333NA-6	RMGCFMIC 33K0 OHM +5% 62MI5W
R222 230	RS3AD0362NA-A	RMGCFMIC 3K6 OHM +5% 62MI5W
R177 179	RS3AD0432NA-4	RMGCFMIC 4K3 OHM +5% 62MI5W
R297 340	RS3AD0470NA-7	RMGCFMIC 47R0 OHM +5% 62MI5W
R3 4 6 9 22 25 27 29 32 34 36 39 46 48 49 51 57 59 73 76 108 127 148 149 178 187 199 206 211 284 335 353 354 355 356 357 358 359 360 361 362 363 364 365 366 367 368 369 370 371 372 373 374 375	RS3AD0471NA-5	RMGCFMIC 470R0 OHM +5% 62MI5W
R128	RS3AD0472NA-3	RMGCFMIC 4K7 OHM +5% 62MI5W
R69 70 240 250 260 273 283 285 307 309 312	RS3AD0512NA-6	RMGCFMIC 5K1 OHM +5% 62MI5W
R102 173 180 236	RS3AD0821NA-4	RMGCFMIC 820R0 OHM +5% 62MI5W
R248	RS3AD0912NA-1	RMGCFMIC 9K1 OHM +5% 62MI5W
R201	RS3AD0220NA-8	RMGCFMIC 22R0 OHM +5% 62MI5W
R207 215	RS3AD0562NA-2	RMGCFMIC 5K6 OHM +5% 62MI5W
R351 352	RS3AD0242NA-9	RMGCFMIC 2K4 OHM +5% 62MI5W

Ref Designator	Part Number	Description
<b>Processor PCB</b>		
R322 323 376 377	RS3AD0100NA-7	RMGCFMIC 10R0 OHM +5% 62MI5W
R232 242 243 253 280 290 304 314	RS3AD0101NA-5	RMGCFMIC 100R0 OHM +5% 62MI5W
R122 125	RS3AD0102NA-3	RMGCFMIC 1K0 OHM +5% 62MI5W
R90	RS3AD0104NA-A	RMGCFMIC 100K0 OHM +5% 62MI5W
R135 158	RS3AD0123NA-6	RMGCFMIC 12K0 OHM +5% 62MI5W
R223 262 271 295	RS3AD0183NA-A	RMGCFMIC 18K0 OHM +5% 62MI5W
R7 8 23 24 37 38 53 54 224 228 257 261 272 276 296 300 330 333	RS3AD0222NA-4	RMGCFMIC 2K2 OHM +5% 62MI5W
R156 157 159 160	RS3AD0332NA-8	RMGCFMIC 3K3 OHM +5% 62MI5W
R19 55 83 84 87 219 265 266 267 291	RS3AD0333NA-6	RMGCFMIC 33K0 OHM +5% 62MI5W
R182	RS3AD0471NA-5	RMGCFMIC 470R0 OHM +5% 62MI5W
R320 321 341 342	RS3AD0472NA-3	RMGCFMIC 4K7 OHM +5% 62MI5W
R227 258 275 299 331	RS3AD0474NA-A	RMGCFMIC 470K0 OHM +5% 62MI5W
R197	RS3AD0220NA-8	RMGCFMIC 22R0 OHM +5% 62MI5W
R209 210	RS3AD0153NA-8	RES CHIP,15K 1/16W,+5%,0603.
R318	RC3DI0100IN-2	RCF 10R0 OHM +5% 250MIOV
R97 208	RC3DI0153IN-3	RCF 15K0 OHM +5% 250MIOV
<b>Miscellaneous</b>		
SK1	H01-RLL1296122A-5	RELAYSGNL 12.0V 960.0OHM 3.0A
NJ51 52 53 54	H01-SORA40GNDNN-7	JACK RCA 4P JB040131PN WWRR
NJ55	H01-SORA64105NN-5	JACK RCA 6P JB060132PN
P516	H01-WG04SB81100-3	WIRE ASS'Y DL 2.0MM 4P 110MM UL1007 #26 RED
P508	H01-WN03SD100WH-6	CONN WAFER 2.5MM 3P 5267-03A WHT
P2 517	H01-WN04AB100WH-8	CONN WAFER 2.0MM 4P 35237-0410 WHT
P513	H01-WN04SB00000-3	CONN 2.0MM 4 MA ST NAT GT201-4P-TS
P507 512	H01-WN04SD100WH-3	CONN WAFER 2.5MM 4P 5267-04A WHT
P506 511	H01-WN05SD100WH-0	CONN WAFER 2.5MM 5P 5267-05A WHT
P505	H01-WN06SD100WH-8	CONN WAFER 2.5MM 6P 5267-06A WHT
P510	H01-WN07SD00000-3	CNT PLUG ST 2.5mm 7P 5267-07A
P503	H01-WN14AB100WH-4	CONN WAFER 2.0MM 14P 35237-1410 WHT
P504	H01-WN15SI00000-0	CONN FFC 1.25MM 15P SCB-1115-00-2 VER
P509	H01-WN19AB00000-9	CONN 2.0MM 19 MA R NAT SOCKET MOLEX 35237-1910 0 0
P501	H01-WN19SB00000-6	CONN 2.0MM 19 MA ST NAT MOLEX 35336-1910 0 0
P1	H01-WSE261705EN-0	WIRE ASS'Y 15P 170MM UL2547/1533#26 RED SHIELD
<b>DSP PCB</b>		
<b>Capacitors</b>		
C472 473 474	CEHDC0108NN-3	CE 1MIOF +20% 6.3V 8X11.5 85C ELITE
C5	CEHEC01075E-8	CE 100U0F +20% 10.0V 5X11 85C P5MM
C126 127 128 129 130 131 132 133 134 135 136 137 138 139 140 141 231 232 306 307 308 309 320 321 400 401 402 403 404 405 406 407 408 409 410 411 412 413 414 415 456 457 458 459 460 461 462 463 464 465 613 620 621 727 729 731 733 735	CEHFC01062S-0	CE 10UF +20% 16V D4XL7 P2.5MM 2000hours 85C
C150 151 152 153 233 549 618 630 649 723 800 807 811 820 822 828 830	CEHFC01072S-9	CE 100UF +20% 16V D6.3XL7 P2.5MM 2000hours 85C
C211 212 213 214 627	CEHFC04762S-0	CE 47UF +20% 16V D5XL7 P2.5MM 2000hours 85C
C203 204 205 206 207 208 209 210 223 224 225 226 227 228 229 230 559 648	CEHIC01055E-6	CE 1UF +20% 50V D5XL11 P5MM 85C
C806	CEHIC02255E-7	CE 2U2F +20% 50V D5XL11 P5MM 85C
C619	CEHIC01042S-5	CE 100NF +20% 50V SSE TYPE D4XL7 P2.5MM 85C
C470 471	H01-CEMFC0108AH-0	CAP ELEC 1000UF 16V M 10X16 SHL SAMYOUNG
C725	H01-CEMIC0475AH-8	CE 4.7UF 50V M 5X11 SHL SAMYOUNG
C30	CEHEC0477MN-A	CE 470U0F +20% 10.0V 6.3X11 85C ELITE
C657	H01-CEZXA0479MN-5	CM 47MIOF +80% -20% 5.5V 70C SCDA5R5473V

Ref Designator	Part Number	Description
<b>DSP PCB</b>		
C100 101 102 103 104 105 106 107 108 109 110 111 112 113 114 115 235 236 237 238 600 601 602 603 604 605 606 608 611 615 616 625 626 704	CZJII0101BE-2	CCCFMIC 100P0F +5% -5% 50.0V NP0 0603
C700 702 752	CZJII0220BE-5	CCCFMIC 22P0F +5% -5% 50.0V NP0 0603
C890	CZJII0471BE-2	CCCFMIC 470P0F +5% -5% 50.0V NP0 0603
C314 315 318 319 432 433 434 435 436 437 438 439 440 441 442 443 444 445 446 447	CZJII0561CE-0	CCCFMIN 560P0F +5% -5% 50.0V NP0 0805
C805	CZJII0680BE-4	CAPACITOR CERAMIC CHIP 68PF 50V CH J NPO 0603
C243 244 721	CZKII0102BC-7	CAP CHIP 1N0F +10% -10% 50.0V X7R 0603
C18 19 20 21 24 25 32 33 34 35 37 38 39 41 43 711 713	CZKII0103BC-5	CAP CHIP 10N0F +10% -10% 50.0V X7R 0603
C804	CZKII0122BC-1	CAP CHIP 1N2F +10% -10% 50.0V X7R 0603
C6 8	CZJII0331BE-7	CCCFMIC 330P0F +5% -5% 50.0V NP0 0603
C310 311 312 313 416 417 418 419 420 421 422 423 424 425 426 427 428 429 430 431	CZKII0272BC-4	CAP CHIP 2N7F +10% -10% 50.0V X7R 0603
C13 116 117 118 119 120 121 122 123 124 125 154 155 156 157 158 159 160 161 162 163 164 165 167 168 169 170 171 172 173 174 191 192 193 194 195 196 197 198 199 200 201 202 215 216 217 218 219 220 221 222 234 23 28 29 31 36 316 317 390 391 392 393 394 468 469 612 614 617 622 624 628 629 647 650 701 705 708 710 712 714 718 719 722 724 726 728 730 732 734 742 801 803 808 809 810 814 815 816 818 819 821 829	CZZFI0104BF-8	CAP CHIP 100N0F +80% -20% 16.0V Y5V 0603
C142 143 144 145 146 147 148 149 175 176 177 178 179 180 181 182	CZJII0101BE-2	CCCFMIC 100P0F +5% -5% 50.0V NP0 0603
C743	CZJII0220BE-5	CCCFMIC 22P0F +5% -5% 50.0V NP0 0603
C466 467	CZJII0561CE-0	CCCFMIN 560P0F +5% -5% 50.0V NP0 0805
C183 184 185 186 187 188 189 190	CZKII0102BC-7	CAP CHIP 1N0F +10% -10% 50.0V X7R 0603
C40 42 44 703 706 709 716 717 751	CZKII0103BC-5	CAP CHIP 10N0F +10% -10% 50.0V X7R 0603
C11 12 22 26 27 239 240 241 242 448 449 450 451 452 453 454 455	CZZFI0104BF-8	CAP CHIP 100N0F +80% -20% 16.0V Y5V 0603
C7	CZJII0390BE-2	CAP CHIP 39PF 50V CH J NPO 0603
C720	CZKGI0183BC-6	CAP CHIP 18NF 25V +/-10% 0603 X7R
C9	CZKII0221BA-3	CAP CHIP 220PF 50V K SL 0603
<i>Semiconductors</i>		
Q611	H01-TRMPSA06NNA-4	TR-SLPLF MP5A06 N 500MIOA TO-92
IC21	H01-ICKA78R08I2-4	IC-KA78R08API TO-220IS-4PIN
D600 602 603 604 605	H01-DS1S50094NB-A	D-SLP 1SS355 35.0V 225MIOA
IC804	H01-IC49L8192I5-A	IC-FLASH MEMORY ROM AT49LV8192A 70ns
IC17 18 25	H01-IC74V244MG5-3	IC-LOGIC 74VHCT244A INVERTER CMOS
IC5	H01-ICBU4053BB4-7	IC BU4053BCF SOP16 ANALOG MPX/DEMPX
IC16	H01-ICBU4094BD3-2	IC CMOS BU4094BF SOP16
IC13	H01-ICCS42528EC-0	IC-CODEC CS42528CQ
IC26	H01-ICCS4391AD8-5	IC CONV CS4391A-KZ SOP20
IC11	H01-ICCS49400ED-3	IC-DSP CS494003-CQ LQFP144
IC27 28 29 30	H01-ICCS5361KG4-0	IC-CONV CS5361-KZ A/D TSSOP24
IC12	H01-ICD703033E1-5	IC-MICOM FLASH NEC UPD70F3033BGF 0228KK001 JAPAN QFP100
IC14	H01-ICK4S1616M6-9	IC-SDRAM K4S161622E-TC70 OR TC80
IC31 32 33 34 35 36 37 38 39 40 41 42 43 44 45 46 47 48 49 50	H01-ICLM02068D2-A	IC-OPERAMP NJM2068M DUAL SOP8
IC22	H01-ICM24C04WD2-1	IC-EEPROM M24C04WMM6T
IC19 20	H01-ICM74H04MD4-2	IC-LOGIC M74HCU04M1R INVERTER HCT

Ref Designator	Part Number	Description
<b>DSP PCB</b>		
IC24	H01-ICMM1662HI3-2	IC MM1662H LOW DROP VOLTAGE REGULATOR SOP-8
IC23	H01-ICNJU6324D2-3	IC-SPECFUNC NJU6324M SOP8 CMOS CRYSTAL
Q600 601 604 605 606 607 608 609 612 613	H01-TRDTC114YNI-5	TR-SSD DTC114YKA N 10K0 OHM 47K0 OHM
D601	H01-DS1S50094NB-A	D-SLP 1SS355 35.0V 225MIOA
Q402 403	H01-TRDTA114YNI-9	TR-SSD DTA114YKA P 10K0 OHM 47K0 OHM
Q400 401	H01-TRKTD1304ND-5	TR-SLPSWA KTD1304 N 20V 300MIOA SOT-23
<i>Resistors</i>		
R735	RS3AD0391NA-3	RMGCFMIC 390R0 OHM +5% 62MI5W
R619	RC3DI010AIN-1	RCF 1R0 OHM +5% 250MIOW
R22	RC3DI0560IN-1	RCF 56 OHM +5% 250MIOW
R23	RC3DI022AIN-2	RCF 2R2 OHM +5% 250MIOW
R27 28 29 30 715	RS3AD0101NA-5	RMGCFMIC 100R0 OHM +5% 62MI5W
R100 101 102 103 104 106 107 701	RS3AD0102NA-3	RMGCFMIC 1K0 OHM +5% 62MI5W
R180 181 182 183 184 185 186 187 238 239 242 243 621 654 741 753 756 802	RS3AD0103NA-1	RMGCFMIC 10K0 OHM +5% 62MI5W
R140 141 142 143 144 145 146 147 315 316 448 449 450 451 452 453 454 470 471	RS3AD0104NA-A	RMGCFMIC 100K0 OHM +5% 62MI5W
R305 306 307 308 416 417 418 419 420 421 422 423 424 425 426 427 428 429 430 431	RS3AD0122NA-8	RMGCFMIC 1K2 OHM +5% 62MI5W
R132 133 134 135 136 137 138 139 196 197 198 199 200 201 202 203 246 247	RS3AD0151NA-1	RMGCFMIC 150R0 OHM +5% 62MI5W
R799	RS3AD0200NA-3	RES_CHIP 20 OHM 1/16W +/-5% 0603
R234 235	RS3AD0203NA-8	RMGCFMIC 20K0 OHM +5% 62MI5W
R24	RS3AD0221NA-6	RMGCFMIC 220R0 OHM +5% 62MI5W
R870	RS3AD0302NA-6	RMGCFMIC 3K0 OHM +5% 62MI5W
R744 876 877 878	RS3AD0332NA-8	RMGCFMIC 3K3 OHM +5% 62MI5W
R400 401 402 403 404 405 406 407 408 409 410 411 412 413 414 415	RS3AD0432NA-4	RMGCFMIC 4K3 OHM +5% 62MI5W
R1 4 105 157 166 167 168 169 170 171 236 237 301 302 303 304 526	RS3AD0472NA-3	RMGCFMIC 4K7 OHM +5% 62MI5W
R108 109 110 111 112 114 115 148 149 150 151 152 153 154 155 232 233 620 623	RS3AD0473NA-1	RMGCFMIC 47K0 OHM +5% 62MI5W
R313 314 456 457 458 459 460 461 462 463	RS3AD0561NA-4	RMGCFMIC 560R0 OHM +5% 62MI5W
R309 310 311 312 432 433 434 435 436 437 438 439 440 441 442 443 444 445 446 447	RS3AD0562NA-2	RMGCFMIC 5K6 OHM +5% 62MI5W
R113	RS3AD0682NA-3	RMGCFMIC 6K8 OHM +5% 62MI5W
R700 705 754	RS3AD0750NA-1	RMGCFMIC 75R0 OHM +5% 62MI5W
R124 125 126 127 128 129 130 131	RS3AD0000NA-0	RMGCFMIC 0 OHM +0% 62MI5W
R3 6 7 8 626 627	RS3AD0000NA-0	RMGCFMIC 0 OHM +0% 62MI5W
R708 719 729 730 731 732 733 734	RS3AD0100NA-7	RMGCFMIC 10R0 OHM +5% 62MI5W
R21 26 31 632 711 720	RS3AD0101NA-5	RMGCFMIC 100R0 OHM +5% 62MI5W
R10 12 466 467 472 473 600 601 602 603 604 605 606 607 608 609 610 617 618 628 629 630 631 641	RS3AD0102NA-3	RMGCFMIC 1K0 OHM +5% 62MI5W
R5 9 14 16 17 172 173 174 175 176 177 178 179 188 189 190 191 192 193 194 195 216 217 218 219 220 221 222 223 224 225 226 227 228 229 230 231 240 241 611 612 613 615 616 624 868 869 871 872 873 874	RS3AD0103NA-1	RMGCFMIC 10K0 OHM +5% 62MI5W
R455 622	RS3AD0104NA-A	RMGCFMIC 100K0 OHM +5% 62MI5W
R464 465	RS3AD0122NA-8	RMGCFMIC 1K2 OHM +5% 62MI5W
R204 205 206 207 208 209 210 211 244 245	RS3AD0151NA-1	RMGCFMIC 150R0 OHM +5% 62MI5W
R156 158 159 160 161 162 163 527	RS3AD0203NA-8	RMGCFMIC 20K0 OHM +5% 62MI5W

Ref Designator	Part Number	Description
<b>DSP PCB</b>		
R725 736 738 752	RS3AD0222NA-4	RMGCFMIC 2K2 OHM +5% 62MI5W
R2 875	RS3AD0332NA-8	RMGCFMIC 3K3 OHM +5% 62MI5W
R25 710 722	RS3AD0471NA-5	RMGCFMIC 470R0 OHM +5% 62MI5W
R18 19 20	RS3AD0472NA-3	RMGCFMIC 4K7 OHM +5% 62MI5W
R15 702 706 724 727 737 739 751 755	RS3AD0473NA-1	RMGCFMIC 47K0 OHM +5% 62MI5W
R709 721	RS3AD0511NA-8	RMGCFMIC 510R0 OHM +5% 62MI5W
R468 469 704 717 726 743	RS3AD0561NA-4	RMGCFMIC 560R0 OHM +5% 62MI5W
R723	RS3AD0750NA-1	RMGCFMIC 75R0 OHM +5% 62MI5W
R625	RS3AD0822NA-2	RMGCFMIC 8K2 OHM +5% 62MI5W
RX21 23 25 26 27	RS3AY0103NA-7	RCA 10K0 OHM +5% 62M15W 4
RX22 24	RS3AY0332NA-3	RCA 3K3 OHM +5% 62M15W 4
RX11 12 13 14 15 16 17 18 19	RS3AY0470NA-2	RCA 47R0 OHM +5% 62M15W 4
R11 13 745 746	RS3AD0221NA-6	RMGCFMIC 220R0 OHM +5% 62MI5W
<i>Miscellaneous</i>		
L2 3 4 5	H01-LAINB0470CR-2	LF 47U0H +10% 5.8 OHM 500MIOA
L600	H01-LAINB047ACR-3	LF 4U7H +10% 1.7 OHM 190.OA
L100 101 102 103 104 105 106 107 108 109 110 111 706 712 714 804 805 R879	H01-FB3002012NN-4	FBEAD SURFACE MT 300OHM FCM2012V-301T07
L112 113 114 18 703 707 710 711 800 802 803	H01-FB3002012NN-4	FBEAD SURFACE MT 300OHM FCM2012V-301T07
L700	H01-FB2K52012NN-5	FBEAD SURFACE MT 2500OHM FCM2012H-252T02
TF11 12	H01-LF11030A2NA-4	TFPULSE TRANSFORMER 110UH FP-110 FERRIT MAGNET
Y800	H01-OSCEM24M5RU-A	VCXO 24M576 HZ +50 PPM -50 PPM 0 OHM 3.3V
Y600	H01-OSCNI20MOCU-6	CSTLS20MOX51-B0
NJ12	H01-SORA40RSANN-6	JACK RCA 4P JB040131ZN GN BN PP TA
NJ11	H01-SORA40RSCNN-A	JACK RCA 4P JB040131QN WH BU RD GY
NJ14 15 16	H01-SOTOR179LBA-0	D-LEM TORX-179L
NJ17	H01-SOTOT179LBA-7	D-LEM TOTX-179L
N105	H01-WG09SB83000-A	WIRE ASS'Y 2.0MM 9P 300MM UL1007#26 WHT
P104	H01-WN04AB100WH-8	CONN WAFER 2.0MM 4P 35237-0410 WHT
P117	H01-WN04SB00000-3	CONN 2.0MM 4 MA ST NAT GT201-4P-TS
P102	H01-WN06SB00000-8	CONN 2.0MM 6 MA ST NAT GT201-6P-TS
P101	H01-WN08SB00000-2	CONN 2.0MM 8 MA ST NAT GT201-8P-TS
P106	H01-WN15AI00000-3	CONN FFC 1.25MM 15P SCB-1015-00-2 ANG
P1 110	H01-WN15SB00000-7	CONN 2.0MM 15 MA ST NAT GT201-15P-TS
P107 108	H01-WN19AB00000-9	CONN 2.0MM 19 MA R NAT SOCKET MOLEX 35237-1910 0 0
P103	H01-WN23SI00000-2	CONN FFC 1.25MM 23P SCB-1123-00-2 VER
NJ13	H01-SQJB04013HN-5	JACK RCA 4P OR ,OR, OR, OR JB040131HN
<b>3 CHANNEL AMP</b>		
<i>Capacitors</i>		
C105 205 305	CCJIC0120NN-2	CAP CERAMIC 12PF 50V J CH TAP
C102 202 302	CKKIC0101NC-9	CAP CERAMIC 100PF 50V K X7R TAP
C106 206 306	CKKIC0221NC-A	CAP CERAMIC 220PF 50V K X7R TAP
C103 203 303	CKKIC0681NA-2	CC 680P0F +10% -10% 50.0V Y5P
C118 218 318 901 918	CEHEC0477MN-A	CE 470U0F +20% 10.0V 6.3X11 85C ELITE
C104 204 304	CEHGC0107MN-7	CE 100U0F +20% 25.0V 6.3X11P2.5MM 85C
C902	CEHIC01055E-6	CE 1UF +20% 50V D5XL11 P5MM 85C
C113 114 213 214 313 314	CEHIC04765E-4	CE 47U0F +20% 50.0V 85C P5MM
C917	CEMIC02265E-9	CAP, ELECT, 22uF, 50V +/-20%
C115 116 215 216 315 316	CPIKC0103NN-0	CAP POLY NON METAL 10NF 100V 10%
C162 164 262 264 362 364	CPIKC0472NN-2	CAP POLY NON METAL 4N7F 100V 10%
C161 261 361	CPIKC0473NN-0	CPF 47N0F +10% 100.0V
C117 217 317	CPJJC0683NN-A	CAP POLY NON METAL 68NF 63V J TAP
C101 201 301	H01-CEMFC01062H-6	CAP ELEC 10UF 16V M 5X11 SHL P2.5MM
C107 108 207 208 307 308 903 904	CFIOC0104NN-5	CPM 100N0F +10% 250.0V

Ref Designator	Part Number	Description
<b>3 CHANNEL AMP</b>		
C109 110 111 112 209 210 211 212 309 310 311 312	H01-CEMKA0127AH-0	CAP ELEC 120UF 100V M 12X16 AHS
<i>Semiconductors</i>		
D907	H01-DZ1N05231NB-1	D-ZENER 1N5231B 5.1V 500MIOW
D107 207 307	H01-DR1N04004NA-1	D-SR 1N4004 400.0V 1.0A
D101 104 105 108 201 204 205 208 301 304 305 308 901 902 908 909 910	H01-DG1N04148NB-4	D-SLP 1N4148 100.0V 150E-3A
D102 103 202 203 302 303	H01-DR01SS244NA-2	DIODE 1SS244 220V
Q926 927 928	H01-TR2SC1740NW-9	TR-SLPLF 2SC1740S R N 150MIOA 50V
Q901	H01-TRKTA1024NA-7	TR-SLPLF KTA1024 Y P 50MIOA -150V
Q925	H01-TRKTA1266NA-0	TR-SLPLF KTA1266 Y P 150MIOA
Q107 207 307	H01-TRKTA1268NA-4	TR-SHPLF KTA1268BL P 100MIOA 120V
Q105 123 205 223 305 323	H01-TRKTC3198NA-3	TR-SLPLF KTC3198BL N 150MIOA
Q101 102 103 104 122 201 202 203 204 222 301 302 303 304 322	H01-TRKTC3200NA-9	TR-SHPLF KTC3200BL N 100MIOA 120V
Q902	H01-TRDTC114YNW-6	TR-SLPLF DTC114YSA N 100MIOA
Q108 109 116 208 209 216 308 309 316	H01-TR2SA1360BC-6	TRANSISTOR PNP 2SA1360-Y 50MIOA -150V
Q106 206 306	H01-TR2SA1370BC-7	TRANSISTOR PNP 2SA1370-E 100MIOA 40 320
Q115 215 315	H01-TR2SA1859BC-2	TR-SHPLF 2SA1859A P -2.0A
Q120 121 220 221 320 321	H01-TR2SA1943RP-A	TRANSISTOR PNP 2SA1943-O TO-220
Q110 111 114 210 211 214 310 311 314	H01-TR2SC3423BC-0	TRANSISTOR NPN 2SC3423-Y 50MIOA 150V
Q112 212 312	H01-TR2SC4137BE-0	TR-SHPLF 2SC4137 N 100MIOA 20V
Q117 217 317	H01-TR2SC4883BC-8	TR-SHPLF 2SC4883A N 2.0A
Q118 119 218 219 318 319	H01-TR2SC5200RP-6	TRANSISTOR NPN 2SC5200-O TO-220
<i>Resistors</i>		
R138 139 238 239 338 339	H01-RM3FC022ANN-0	RESISTOR METAL OXIDE 2R2 OHM 1W 5%
R106 107 108 206 207 208 306 307 308	RC3DI0101IN-0	RCF 100R0 OHM +5% 250MIOW
R101 201 301 965	RC3DI0102IN-9	RCF 1K0 OHM +5% 250MIOW
R963	RC3DI0103IN-7	RCF 10K0 OHM +5% 250MIOW
R961 966	RC3DI0104IN-5	RCF 100K0 OHM +5% 250MIOW
R144 145 244 245 344 345	RC3DI0122IN-3	RCF 1K2 OHM +5% 250MIOW
R120 121 122 123 220 221 222 223 320 321 322 323	RC3DI0151IN-7	RCF 150 OHM 5% 1/4W
R103 104 203 204 303 304	RC3DI0152IN-5	RCF 1K5 OHM +5% 250MIOW
R124 125 146 224 225 246 324 325 346	RC3DI0153IN-3	RCF 15K0 OHM +5% 250MIOW
R901	RC3DI0181IN-9	RCF 180 OHM +5% 250MIOW
R967 968	RC3DI0182IN-7	RCF 1K8 OHM 5% 1/4W
R148 149 248 249 348 349	RC3DI0220IN-3	RESISTOR CARBON FILM 220OHM 1/4W 5%
R109 209 309	RC3DI0221IN-1	RCF 220R0 OHM +5% 250MIOW
R126 156 226 256 326 356	RC3DI0222IN-A	RCF 2K2 OHM +5% 250MIOW
R969	RC3DI0332IN-3	RCF 3K3 OHM 5% 1/4W
R150 250 350 973	RC3DI0333IN-1	RCF 33K0 OHM +5% 250MIOW
R105 205 305	RC3DI0471IN-0	RCF 470R0 OHM +5% 250MIOW
R155 170 255 270 355 370 902	RC3DI0473IN-7	RCF 47K OHM +5% 250MIOW
R157 257 357	RC3DI0560IN-1	RCF 56 OHM +5% 250MIOW
R114 115 116 117 118 119 214 215 216 217 218 219 314 315 316 317 318 319	RC3DI0561IN-A	RCF 560R0 OHM +5% 250MIOW
R964	RC3DI0562IN-8	RCF 5K6 OHM +5% 250MIOW
R129 229 329	RC3DI0621IN-7	RCF 620 OHM +5% 250MIOW
R147 247 347	RC3DI0682IN-9	RCF 6K8 OHM +5% 250MIOW
R962	RC3DI0683IN-7	RCF 68K OHM 5% 1/4W
R112 212 312	H01-RC1QC2431IN-6	RES CARBON FILM 2K43 OHM 1/5W 1%
R102 111 202 211 302 311	RM1DI0333IN-4	RMF 33K0 OHM +1% 250MIOW
R140 141 142 143 240 241 242 243 340 341 342 343	H01-RM3EG0100LN-A	RMF 10R0 OHM +5% 500MIOW
R134 135 234 235 334 335	H01-RM3EG0101LN-1	RESISTOR METAL OXIDE 100 OHM 1/2W 5%

Ref Designator	Part Number	Description
<b>3 CHANNEL AMP</b>		
R136 137 236 237 336 337	H01-RM3EG0150LN-4	RESISTOR METAL OXIDE 15 OHM 1/2W 5%
R132 133 232 233 332 333	H01-RM3EG022ALN-0	RESISTOR METAL OXIDE 2R2 OHM 1/2W 5%
R110 210 310	H01-RM3EG0820LN-9	RESISTOR METAL OXIDE 82 OHM 1/2W 5%
R113 213 313	H01-RC1QC2671IN-6	RES CARBON FILM 2K67 OHM 1/5W 1%
R130 131 230 231 330 331	H01-RM3FC0560BN-5	RESISTOR METAL OXIDE 56 OHM 1W 5%
R171 172 271 272 371 372	H01-RI3IC022BEN-8	RW 220MI0 OHM +5% 5.0W 100PPM/C -100PPM/C
<i>Miscellaneous</i>		
B101 102 103 104 201 202 203 204 301 302 303 304	H01-FB44HM15300-4	LF BEADS 44.1530HM 100MHZ FB-30 HC-3550
G302 303	H01-ZNMSA4004SN-4	TERMLUG GND
N309	H01-WG03SE83800-8	WIRE ASS'Y 3.96MM 3P 160/300/380MM UL1007#16 STR BLU
N310	H01-WG03SE83700-6	WIRE ASS'Y 3.96MM 3P 140/260/370MM UL1007#16 STR RED
L101 201 301	H01-LC>NNNA050NA-1	LFA 1MM 10MM 5 LEFT 0.0MM NONE
SK11 21 31	H01-RL1K124V05A-2	RELAY SGNL OMI-SS-224L 1K1 OHM 24V 5A
R161 261 361	H01-RM3GC0100CN-7	RESISTOR METAL OXIDE 10R0 OHM +5% 2.0W
RV12 22 32	H01-RT7EA0201NB-6	PR 200R0 OHM +20% 500MI0W
RV11 21 31	H01-RT7EA0500NB-9	PR 50R0 OHM +20% 500MI0W
NJ33	H01-SOSP20117NN-6	JACK SPEAKER 2P B30290117N BK/WH
NJ32	H01-SOSP20118NN-8	JACK SPEAKER 2P B30290118N BK/BU
NJ31	H01-SOSP20119NN-A	JACK SPEAKER 2P B30290119N BK/BRN
N312	H01-WG02SE82500-4	WIRE ASS'Y 3.96MM 2P 170/250MM UL1007#18 BLU
P702	H01-WG02SE852BK-9	WIRE ASS'Y 3.96MM 2P 520MM UL1007#16 BLK
N704	H01-WG02SE852RD-7	WIRE ASS'Y 3.96MM 2P 520MM UL1007#16 RED
N311	H01-WG03SE82000-2	WIRE ASS'Y 3.96MM 3P 200MM UL1007#16 RED
N306	H01-WG03SE82300-8	WIRE ASS'Y 3.96MM 3P 230/200/230MM UL1007#18 WHT
P337 384 385 386	H01-WN02SD00000-7	CONN 2.5MM 2 MA ST NAT 0 0
P202	H01-WN04SD100WH-3	CONN WAFER 2.5MM 4P 5267-04A WHT
P316 317 318	H01-WN07AB100WH-A	CONN WAFER 2.0MM 7P 35237-0710 WHT
P321 322 323	H01-WN07SB100WH-7	CONN WAFER 2.0MM 7P 35336-0710 WHT
N303	H01-WS4242413FN-0	WIRE ASS'Y 2.5MM 4P 240MM UL1007/2547#24/26 SHIELD
N302	H01-WS5241523FN-7	WIRE ASS'Y 2.5MM 5P 150MM UL1007/2547 #24/26 SHIELD
N301	H01-WS7241543FN-1	WIRE ASS'Y 2.5MM 7P 150MM UL1007/2547 #24/26 SHIELD
<b>4 CHANNEL AMP</b>		
<i>Capacitors</i>		
C405 505 605 705	CCJIC0120NN-2	CAP CERAMIC 12PF 50V J CH TAP
C402 502 602 702	CCKIC0101NC-9	CAP CERAMIC 100PF 50V K X7R TAP
C406 506 606 706	CCKIC0221NC-A	CAP CERAMIC 220PF 50V K X7R TAP
C403 503 603 703	CCKIC0681NA-2	CC 680P0F +10% -10% 50.0V Y5P
C418 518 618 718 801	CEHEC0477MN-A	CE 470U0F +20% 10.0V 6.3X11 85C ELITE
C404 504 604 704	CEHGC0107MN-7	CE 100U0F +20% 25.0V 6.3X11P2.5MM 85C
C802	CEHIC01055E-6	CE 1UF +20% 50V D5XL11 P5MM 85C
C413 414 513 514 613 614 713 714	CEHIC04765E-4	CE 47U0F +20% 50.0V 85C P5MM
C415 416 515 516 615 616 715 716	CPIKC0103NN-0	CAP POLY NON METAL 10NF 100V 10%
C562 564 662 664 762 764 862 864	CPIKC0472NN-2	CAP POLY NON METAL 4N7F 100V 10%
C461 561 661 761	CPIKC0473NN-0	CPF 47N0F +10% 100.0V
C417 517 617 717	CPJJC0683NN-A	CAP POLY NON METAL 68NF 63V J TAP
C401 501 601 701	H01-CEMFC01062H-6	CAP ELEC 10UF 16V M 5X11 SHL P2.5MM
C407 408 507 508 607 608 707 708 803 804	CFIOC0104NN-5	CPM 100N0F +10% 250.0V
C409 410 411 412 509 510 511 512 609 610 611 612 709 710 711 712	H01-CEMKA0127AH-0	CAP ELEC 120UF 100V M 12X16 AHS



Ref Designator	Part Number	Description
<b>4 CHANNEL AMP</b>		
<i>Semiconductors</i>		
D401 404 405 408 501 504 505 508 601 604 605 608 701 704 705 708 801 802	H01-DG1N04148NB-4	D-SLP 1N4148 100.0V 150E-3A
D407 507 607 707	H01-DR1N04004NA-1	D-SR 1N4004 400.0V 1.0A
Q801	H01-TRKTA1024NA-7	TR-SLPLF KTA1024 Y P 50MIOA -150V
Q407 507 607 707	H01-TRKTA1268NA-4	TR-SHPLF KTA1268BL P 100MIOA 120V
Q405 423 505 523 605 623 705 723	H01-TRKTC3198NA-3	TR-SLPLF KTC3198BL N 150MIOA
Q401 402 403 404 422 501 502 503 504 522 601 602 603 604 622 701 702 703 704 722	H01-TRKTC3200NA-9	TR-SHPLF KTC3200BL N 100MIOA 120V
Q802	H01-TRDTC114YNW-6	TR-SLPLF DTC114YSA N 100MIOA
Q408 409 416 508 509 516 608 609 616 708 709 716	H01-TR2SA1360BC-6	TRANSISTOR PNP 2SA1360-Y 50MIOA -150V
Q406 506 606 706	H01-TR2SA1370BC-7	TRANSISTOR PNP 2SA1370-E 100MIOA 40 320
Q415 515 615 715	H01-TR2SA1859BC-2	TR-SHPLF 2SA1859A P -2.0A
Q420 421 520 521 620 621 720 721	H01-TR2SA1943RP-A	TRANSISTOR PNP 2SA1943-O TO-220
Q410 411 414 510 511 514 610 611 614 710 711 714	H01-TR2SC3423BC-0	TRANSISTOR NPN 2SC3423-Y 50MIOA 150V
Q412 512 612 712	H01-TR2SC4137BE-0	TR-SHPLF 2SC4137 N 100MIOA 20V
Q417 517 617 717	H01-TR2SC4883BC-8	TR-SHPLF 2SC4883A N 2.0A
Q418 419 518 519 618 619 718 719	H01-TR2SC5200RP-6	TRANSISTOR NPN 2SC5200-O TO-220
D402 403 502 503 602 603 702 703	H01-DR01SS244NA-2	DIODE 1SS244 220V
<i>Resistors</i>		
R406 407 408 506 507 508 606 607 608 706 707 708	RC3DI0101IN-0	RCF 100R0 OHM +5% 250MIOW
R401 501 601 701	RC3DI0102IN-9	RCF 1K0 OHM +5% 250MIOW
R444 445 544 545 644 645 744 745	RC3DI0122IN-3	RCF 1K2 OHM +5% 250MIOW
R420 421 422 423 520 521 522 523 620 621 622 623 720 721 722 723	RC3DI0151IN-7	RCF 150 OHM 5% 1/4W
R403 404 503 504 603 604 703 704	RC3DI0152IN-5	RCF 1K5 OHM +5% 250MIOW
R424 425 446 524 525 546 624 625 646 724 725 746	RC3DI0153IN-3	RCF 15K0 OHM +5% 250MIOW
R801	RC3DI0181IN-9	RCF 180 OHM +5% 250MIOW
R448 449 548 549 648 649 748 749	RC3DI0220IN-3	RESISTOR CARBON FILM 220OHM 1/4W 5%
R409 509 609 709	RC3DI0221IN-1	RCF 220R0 OHM +5% 250MIOW
R426 456 526 556 626 656 726 756	RC3DI0222IN-A	RCF 2K2 OHM +5% 250MIOW
R450 550 650 750	RC3DI0333IN-1	RCF 33K0 OHM +5% 250MIOW
R405 505 605 705	RC3DI0471IN-0	RCF 470R0 OHM +5% 250MIOW
R455 470 555 570 655 670 755 770 802	RC3DI0473IN-7	RCF 47K OHM +5% 250MIOW
R457 557 657 757	RC3DI0560IN-1	RCF 56 OHM +5% 250MIOW
R414 415 416 417 418 419 514 515 516 517 518 519 614 615 616 617 618 619 714 715 716 717 718 719	RC3DI0561IN-A	RCF 560R0 OHM +5% 250MIOW
R429 529 629 729	RC3DI0621IN-7	RCF 620 OHM +5% 250MIOW
R447 547 647 747	RC3DI0682IN-9	RCF 6K8 OHM +5% 250MIOW
R412 512 612 712	H01-RC1QC2431IN-6	RES CARBON FILM 2K43 OHM 1/5W 1%
R413 513 613 713	H01-RC1QC2671IN-6	RES CARBON FILM 2K67 OHM 1/5W 1%
R402 411 502 511 602 611 702 711	RM1DI0333IN-4	RMF 33K0 OHM +1% 250MIOW
B401 402 403 404 501 502 503 504 601 602 603 604 701 702 703 704	H01-FB44HM15300-4	LF BEADS 44.1530HM 100MHZ FB-30 HC-3550
R440 441 442 443 540 541 542 543 640 641 642 643 740 741 742 743	H01-RM3EG0100LN-A	RMF 10R0 OHM +5% 500MIOW
R434 435 534 535 634 635 734 735	H01-RM3EG0101LN-1	RESISTOR METAL OXIDE 100 OHM 1/2W 5%
R436 437 536 537 636 637 736 737	H01-RM3EG0150LN-4	RESISTOR METAL OXIDE 15 OHM 1/2W 5%
R432 433 532 533 632 633 732 733	H01-RM3EG022ALN-0	RESISTOR METAL OXIDE 2R2 OHM 1/2W 5%
R410 510 610 710	H01-RM3EG0820LN-9	RESISTOR METAL OXIDE 82 OHM 1/2W 5%
R438 439 538 539 638 639 738 739	H01-RM3FC022ANN-0	RESISTOR METAL OXIDE 2R2 OHM 1W 5%
R430 431 530 531 630 631 730 731	H01-RM3FC0560BN-5	RESISTOR METAL OXIDE 56 OHM 1W 5%
R461 561 661 761	H01-RM3GC0100CN-7	RESISTOR METAL OXIDE 10R0 OHM +5% 2.0W
R471 472 571 572 671 672 771 772	H01-RI3IC022BEN-8	RW 220MIO OHM +5% 5.0W 100PPM/C -100PPM/C

Ref Designator	Part Number	Description
<b>4 CHANNEL AMP</b>		
VR42 52 62 72	H01-RT7EA0201NB-6	PR 200R0 OHM +20% 500MIOW
VR41 51 61 71	H01-RT7EA0500NB-9	PR 50R0 OHM +20% 500MIOW
<i>Miscellaneous</i>		
G401 501 601 701 802	H01-ZNMSA4004SN-4	TERMLUG GND
L401 501 601 701	H01-LCNNNA050NA-1	LFA 1MM 10MM 5 LEFT 0.0MM NONE
SK41 51 61 71	H01-RL1K124V05A-2	RELAY SGNL OMI-SS-224L 1K1 OHM 24V 5A
NJ51	H01-SOSP20115NN-2	JACK SPEAKER 2P B30290115N GY/BK D/N
NJ61	H01-SOSP20116NN-4	JACK SPEAKER 2P B30290116N TAN/BK
NJ41	H01-SOSP40164NN-1	JACK SPEAKER 4P B30490164N GN/BK/R/B
P1 2 3 4 5 6	H01-WE01S7065BK-4	WIRE ASS'Y DIA1.5MM 1P 70MM TUBE L=65MM BLK
N703	H01-WG02SE81200-8	WIRE ASS'Y 3.96MM 2P 120MM UL1007#18 RED
N801	H01-WG02SE81700-7	WIRE ASS'Y 3.96MM 2P 70/170MM UL1007#18 RED
N802	H01-WG02SE82000-5	WIRE ASS'Y 3.96MM 2P 120/200MM UL1007#18 RED
N603	H01-WG02SE82400-2	WIRE ASS'Y 3.96MM 2P 240MM UL1007#18 RED
N503	H01-WG02SE83000-6	WIRE ASS'Y 3.96MM 2P 300MM UL1007#18 RED
N403	H01-WG02SE83800-0	WIRE ASS'Y 3.96MM 2P 380MM UL1007#18 RED
P702	H01-WG02SE852BK-9	WIRE ASS'Y 3.96MM 2P 520MM UL1007#16 BLK
N705	H01-WG02SE852RD-7	WIRE ASS'Y 3.96MM 2P 520MM UL1007#16 RED
N803	H01-WG04SE81800-3	WIRE ASS'Y 3.96MM 4P 180MM UL1007#16 RED
P401 501 601 701 905	H01-WN02SD00000-7	CONN 2.5MM 2 MA ST NAT 0 0
P402	H01-WN04SD100WH-3	CONN WAFER 2.5MM 4P 5267-04A WHT
P416 417 418 419	H01-WN07AB100WH-A	CONN WAFER 2.0MM 7P 35237-0710 WHT
P406 506 606 706	H01-WN07SB100WH-7	CONN WAFER 2.0MM 7P 35336-0710 WHT
N406	H01-WS3262505FB-8	WIRE ASS'Y 2.5MM 3P 250MM UL2547#26 BLK SHIELD
N405	H01-WS4241813FN-4	WIRE ASS'Y 2.5MM 4P 180MM UL1007/2547 #24/26 SHIELD
N402	H01-WS5242623FN-4	WIRE ASS'Y 2.5MM 5P 260MM UL1007/2547#24/26 SHIELD
N401	H01-WS6242933FN-6	WIRE ASS'Y 2.5MM 6P 290MM UL1007/2547 #24/26 SHIELD
<b>FRONT PCB</b>		
<i>Capacitors</i>		
C495	CCZID0104NA-2	CC 100N0F +80% -20% 50.0V F
C710 716 718	CEHFC04765E-3	CE47UF +20% 16.0V D5XL11 P5MM 85C
C701 702 704	CPHKC0473NN-8	CAP POLY NON METAL 47NF 100V +20%
C493 705 706 707 708 721 722 726 727	CZJII0101BE-2	CCCFMIC 100P0F +5% -5% 50.0V NP0 0603
C491 492	CZKII0222BC-8	CAP CHIP 2N2F +10% -10% 50.0V X7R 0603
C713 714	CZKII0223BC-6	CAP CHIP 22N0F +10% -10% 50.0V X7R 0603
C719 720	CZKII0103BC-5	CAP CHIP 10N0F +10% -10% 50.0V X7R 0603
C494 703 715 717 724	CZZFI0104BF-8	CAP CHIP 100N0F +80% -20% 16.0V Y5V 0603
C723	CZJII0330BE-9	CCCFMIC 33P0F +5% -5% 50.0V NP0 0603
<i>Semiconductors</i>		
D720 721	H01-DS05GBUSCNB-A	DIODE PG05GBUSC
D708 710 711 713 715	H01-DS1S50094NB-A	D-SLP 1SS355 35.0V 225MIOA
IC71	H01-ICBU4094BD3-2	IC CMOS BU4094BF SOP16
Q701 703 704 705	H01-TRDTC114YNI-5	TR-SSD DTC114YKA N 10K0 OHM 47K0 OHM
Q702	H01-TRKTD1304ND-5	TR-SLPSWA KTD1304 N 20V 300MIOA SOT-23
D716	H01-DG1N04148NB-4	D-SLP 1N4148 100.0V 150E-3A
D700 702 704 706	H01-DL30B2015AA-A	D-LEM 30B3-20-15 GaN SUPER BLUE WATER CLEAR 15
D717	H01-DL3BA05V0BA-2	D-LEM BLUE/AMBER 3PIE RD RND CL L-3VYMB
D714	H01-DLRED3FRDBA-5	D-LEM RED/GREEN 3F RD RND CL
<i>Resistors</i>		
R760 761	RC3DI0100IN-2	RCF 10R0 OHM +5% 250MIOW
R770 772 774 776	RC3DI0101IN-0	RCF 100R0 OHM +5% 250MIOW

Ref Designator	Part Number	Description
<b>FRONT PCB</b>		
R732 733 734	RC3DI0103IN-7	RCF 10K0 OHM +5% 250MI0W
R740 741	RC3DI0221IN-1	RCF 220R0 OHM +5% 250MI0W
R706 707	RC3DI033AIN-6	RCF 3R3 OHM +5% 250MI0W
R742 743	RC3DI0471IN-0	RCF 470R0 OHM +5% 250MI0W
R738	RS3AD0101NA-5	RMGCFMIC 100R0 OHM +5% 62MI5W
R714 723 735 736 737 739	RS3AD0102NA-3	RMGCFMIC 1K0 OHM +5% 62MI5W
R704 705 751	RS3AD0103NA-1	RMGCFMIC 10K0 OHM +5% 62MI5W
R715 724	RS3AD0122NA-8	RMGCFMIC 1K2 OHM +5% 62MI5W
R716 725	RS3AD0152NA-A	RMGCFMIC 1K5 OHM +5% 62MI5W
R722 731	RS3AD0183NA-A	RMGCFMIC 18K0 OHM +5% 62MI5W
R717 726	RS3AD0222NA-4	RMGCFMIC 2K2 OHM +5% 62MI5W
R718 727	RS3AD0272NA-0	RMGCFMIC 2K7 OHM +5% 62MI5W
R719 728	RS3AD0332NA-8	RMGCFMIC 3K3 OHM +5% 62MI5W
R749 750	RS3AD0391NA-3	RMGCFMIC 390R0 OHM +5% 62MI5W
R747 748	RS3AD0471NA-5	RMGCFMIC 470R0 OHM +5% 62MI5W
R720 729	RS3AD0562NA-2	RMGCFMIC 5K6 OHM +5% 62MI5W
R721 730	RS3AD0822NA-2	RMGCFMIC 8K2 OHM +5% 62MI5W
R746	RS3AD0100NA-7	RMGCFMIC 10R0 OHM +5% 62MI5W
<i>Miscellaneous</i>		
L701	H01-LAINB047ACR-3	LF 4U7H +10% 1.7 OHM 190.0A
S701 702 703 704 705 706 707 708 709 710 711 712 713 714 715 716 717 718 719 720	H01-SWC2A112FS1-8	SWITACT VERTICAL SKQNADD010 12V 50MA
RM71	H01-ICRPM6938NN-3	IC-REMOTE RPM6938-RSIP-A3 RECEIVER 38KHZ
NJ71	H01-SORA3313PNN-3	CON PHONO SCKT RCA-313P 3 PINS
NJ72	H01-SORA8OSC5N8-2	JACK S-VIDEO 1P C40160261N
NJ88	H01-SOSS9CKX3NN-9	JACK PHONE 6.35 H70980110S 9P BK
RV71	H01-SWE3AEC11S1-8	VOLUME ENCODER EC11B20203
DP71	H01-VDHCA18LL03-7	FL HCA-18LL03
N703 704	H01-WG04SB809DN-0	WIRE ASS'Y UL1007#26 STR 90MM 2.0MM 4P WHT PIN DOWN
N702	H01-WG11SB83000-8	WIRE ASS'Y 2.0MM 11P 300MM WHT UL1007#26
S1 2 3 4 5 6 7	H01-ZMB01S02200-9	SPRING PLATE GND C5212 0.2T
P707	H01-WN10AB00000-3	CONN 2.0MM GIL-S-10P-S2L2-EF 10P
P701	H01-WN23AI000WH-9	CONN 1.25MM 23 FE ANG WH GF120-23S-LS 2794 A6
N825	H01-WS4265105EN-A	WIRE ASS'Y 2.0MM 4P 510MM UL1533#26 STR SHIELD WHT SHIELD
<b>POWER SUPPLY</b>		
<i>Capacitors</i>		
C400 414 468 487	CCZID0104NA-2	CC 100N0F +80% -20% 50.0V F
C441	CCZGC0104NA-0	CAP CERAMIC 100NF 25V Z Z5U TAP
C442 443	CCZIC0473NA-A	CAP CERAMIC 47NF 50V Z Z5U TAP
C605	CEHDC01075E-4	CE 100U0F +20% 6.3V 85C 5X11 PITCH 5MM
C473	H01-CEMFC0337NN-5	CE 330UF 16V M 8X11.5 SHL
C503 504	CEHGC01075E-5	CE 100U0F +20% 25.0V 6.3X11 85C P5MM
C412 413 467 472 474 475 476 486 505 600 601 602 603 604	CEHIC01055E-6	CE 1UF +20% 50V D5XL11 P5MM 85C
C485 502	CEHIC01065E-4	CE 10U0F +20% 50.0V 85C P5MM 5X11
C484	CEMJA0107NN-1	CAP ELEC 100UF 63V M8*11.5 ELITE
C401 402 403 483 462 463 464 495 496 497	CPIKC0473NN-0	CPF 47N0F +10% 100.0V
C501	H01-CEMHC0227AH-3	CAP ELEC 220UF 35V M 8X11.5 SHL SAMYOUNG
C465	H01-CEMIC0564AH-3	CAP ELEC 0.56UF 50V M 5X11 SHL SAMYOUNG
C416	H01-CEMFC0106AH-7	CAP ELEC 10UF 16V M 5X11 P5MM SHL
C452 453 454 455 456	CFIOC0104NN-5	CPM 100N0F +10% 250.0V
C451 459 460 469 470	CCMPA0472NA-2	CAPACITOR CERAMIC 0.0047UF 400V M
C466	H01-CEMGA0478AH-2	CAP ELEC 4700UF 25V M 16X31.5 SHL
C457 458	H01-CEMZA0399AH-6	CAP ELEC 39000UF 80V M 50X120 AHS
C461	CFMVA0104NN-2	CPPMX 100N0F +20% -20%
C498	H01-CEHFA0688MN-5	CE 6MI8F +20% 16.0V 85C 16X31.5 SHL

Ref Designator	Part Number	Description
<b>POWER SUPPLY</b>		
C606 662 663	CZZFI0104BF-8	CAP CHIP 100N0F +80% -20% 16.0V Y5V 0603
<i>Semiconductors</i>		
D449 450 451 453 454 455 456 457 465 466 472 473 478 479 501 502 503 504 506 507	H01-DR1N04004NA-1	D-SR 1N4004 400.0V 1.0A
D474 475 505	H01-DZMTZJ22BNB-8	DIODE ZENER MTZ J 22B 22V 0.5W DO-34
D508	H01-DZMTZJ5B6NB-5	DIODE ZENER MTZ J5.6B 5.6V 500MW DO-34
D452	H01-DU35A3504WF-2	DIODE BRIDGE BP3504WF 35A
D458	H01-DZ1N05231NB-1	D-ZENER 1N5231B 5.1V 500MIOW
D476	H01-DZMTZ09V1NB-0	D-ZENER MTZJ 9.1V 500MIOW
IC41 47	H01-ICKIA7806I2-9	IC KIA7806AP VOLTAGE REGULATOR TO-220AB
IC42	H01-ICKA78R05I2-9	IC VOLTAGE REGULATOR KIA78R05API TO-220IS-4
IC45	H01-ICBA033T0I2-9	IC-REGPOSFXD BA033T NORMAL
IC43	H01-ICUPD4721D8-3	IC-SPECFUNC UPD4721 DRIVERS/RECEIVERS CMOS RS-232C
Q501	H01-TR2SA933ANW-2	TR-SLPLF 2SA933ASR P -3.0A -20V
Q452 453 454 455 456 460	H01-TRMPSA06NNA-4	TR-SLPLF MP5A06 N 500MIOA TO-92
<i>Resistors</i>		
R504	RC3DI0101IN-0	RCF 100R0 OHM +5% 250MIOW
R458	RC3DI0102IN-9	RCF 1K0 OHM +5% 250MIOW
R457	RC3DI0103IN-7	RCF 10K0 OHM +5% 250MIOW
R505	RC3DI0182IN-7	RCF 1K8 OHM 5% 1/4W
R461 462 467	RC3DI0330IN-7	RESISTOR CARBON FILM 33 OHM 1/4W 5%
R453 454	RC3DI0472IN-9	RCF 4K7 OHM 5% 1/4W
R448	H01-RM3FC010ABN-8	RESISTOR METAL OXIDE 1 OHM 1W 5%
R459	H01-RM3FC0120BN-9	RESISTOR METAL OXIDE 12 OHM 1W 5%
R479 480	H01-RM3FC0123BN-4	RESISTOR METAL OXIDE 12K OHM 1W 5%
R502	H01-RM3FC047ABN-9	RESISTOR METAL OXIDE 4R7 1W 5%
R476 501	H01-RM3GC0100CN-7	RESISTOR METAL OXIDE 10R0 OHM +5% 2.0W
R477	H01-RM3GC022ACN-8	RESISTOR METAL OXIDE 2R2 OHM +5% 2.0W
R455	H01-RM3GC047ACN-9	RESISTOR METAL OXIDE 4R7 +5% 2.0W
R463 692	RS3AD0101NA-5	RMGCFMIC 100R0 OHM +5% 62MI5W
R456 691	RS3AD0102NA-3	RMGCFMIC 1K0 OHM +5% 62MI5W
R464 468 470 473	RS3AD0103NA-1	RMGCFMIC 10K0 OHM +5% 62MI5W
R469 471 474 475	RS3AD0104NA-A	RMGCFMIC 100K0 OHM +5% 62MI5W
R472	RS3AD0222NA-4	RMGCFMIC 2K2 OHM +5% 62MI5W
R465 506 608 609	RS3AD0472NA-3	RMGCFMIC 4K7 OHM +5% 62MI5W
R503	RS3AD0562NA-2	RMGCFMIC 5K6 OHM +5% 62MI5W
R451 452	H01-RI3PA0400NN-9	RESISTOR CEMENT 40 OHM 15W 5% RQA-15
<i>Miscellaneous</i>		
L100	H01-LAINB0470CR-2	LF 47U0H +10% 5.8 OHM 500MIOA
FH11 12 13 14 15 16 17 18 19 20	H01-SOPS1FEHDNN-9	TERMFUSEHLD R FUSE-HOLDER J4210020001X
F454 455	H01-FUGF201A6XX-7	FUSE 239 SERIES 01.6 250V 1.6A
F452	H01-FUGF215A0XX-8	FUSE 65 TS 250V 15A
F451	H01-FUGF23000XX-A	FUSE 239 SERIES 003 250V 3A
SK1 2	H01-RLL12112D1K-9	RELAY OSZ-SS-112DM8 16A 12V
SK41	H01-RLL1227111K-1	RELAYPWR 12.0V 270.0OHM 10.0A
G401	H01-ZNMSA4004SN-4	TERMLUG GND
W601	H01-WG01S008000-7	WIRE ASS'Y UL1007#16 STR 80MM 1P BLK TERMINAL
NJ82	H01-SOAC3A206NN-5	JACK AC OUTLET 3P A206D0054P
NJ85	H01-SORA21502NN-2	CON PHONO SCKT RCA 2P W/GNDCAP CJ020009VN OO
NJ87	H01-SOTOR179LBA-0	D-LEM TORX-179L
NJ86	H01-SOTOT179LBA-7	D-LEM TOTX-179L
NJ81	H01-SOXA27014NN-9	CON MAINS INLET A/C INLET 7014-NGP AC05-4S020A
T451	H01-TXPWMSD05A0-7	TRANSFORMER STBY AVR7300STBY 120V 60HZ EI48X15
N813	H01-WG06SB83200-1	WIRE ASS'Y 320MM 6P UL1007#26 2.0MM STR WHT
N812	H01-WG04SB83600-4	WIRE ASS'Y 360MM 4P UL1007#26 2.0MM STR WHT

Ref Designator	Part Number	Description
<b>POWER SUPPLY</b>		
N816	H01-WG06SB81500-5	WIRE ASS'Y 2.0MM 6P 150MM UL1007#26 WHT
P802 803 815	H01-WN02S12MM00-A	CONNECTOR WAFER B02P-VL 12.0MM 2P
P817 818	H01-WN02SE00101-1	CONNECT 3.96MM 2P 35313-0210
P403	H01-WN03S12MM00-7	CONN WAFER B03P-VL 12.0MM 3P
P819	H01-WN03SE00000-3	CON 3.96MM PITCH MOLEX 35313-0310
P808	H01-WN04SB00000-3	CONN 2.0MM 4 MA ST NAT GT201-4P-TS
P820	H01-WN04SE00000-0	CON 3.96MM PITCH MOLEX 35313-0410
P806	H01-WN05SB00000-0	CONN 2.0MM 5 MA ST NAT GT201-5P-TS
P809	H01-WN06SB00000-8	CONN 2.0MM 6 MA ST NAT GT201-6P-TS
P807	H01-WN07SD00000-3	CNT PLUG ST 2.5mm 7P 5267-07A
P804	H01-WN11SB00001-1	CONN 2.0MM 11P GIL-S-11P-S2T2-EF
N824	H01-WS8267005EN-5	WIRE ASS'Y 2.0MM 8P 700MM UL1007/1533#26 SHIELD WHT
	H01-ZMD05HS0100-7	HEATSINK BRIDGE AVR7300
	H01-ZMD05S06A00-5	BRACKET BRIDGE H/SINK AVR7300
	H01-ZMD05S18A00-5	SHIELD DIGITAL AVR7300
NJ10	SOPA96063NN-0	JACK D-SUB 9P 87204-6063 W/DUST COVER BK
P801	H01-WN02SE00000-6	CON 3.96MM PITCH HEADER 2 POS MOLEX 35328-0210
N462 466	H01-WN02SE00001-A	CONN WAFER 3.96MM 2P YW396-02V
F453	H01-FUGF20008XX-7	FUSE SERIES 239.800 250V 800mA
L653	H01-FB3002012NN-4	FBEAD SURFACE MT 300OHM FCM2012V-301T07
L600 601 602 603 651 652	H01-FB2K52012NN-5	FBEAD SURFACE MT 2500OHM FCM2012H-252T02
L654 655	H01-LS1502012NN-8	INDUCTOR COIL FCI2012-150K 15UH 0805
<b>VIDEO PCB</b>		
<i>Capacitors</i>		
C656 685	CEHEC01075E-8	CE 100U0F +20% 10.0V 5X11 85C P5MM
C601 603 604 606 611 613 618 621 626 628 661 662 667 668	CEHEC02275E-9	CE 220UF +20% 10.0V D6.3XL11 P5MM 85C
C635 636 637 638 639 641	CEHEC0477MN-A	CE 470U0F +20% 10.0V 6.3X11 85C ELITE
C654 655	CEHFC01075E-1	CE 100UF +20% 16.0V D6.3XL11 P5MM 85C
C629 631 632 648 649 651 659 663 664	CEHFC04765E-3	CE47UF +20% 16.0V D5XL11 P5MM 85C
C691 692	CEHIC01065E-4	CE 10U0F +20% 50.0V 85C P5MM 5X11
C688 689	CEHIC02255E-7	CE 2U2F +20% 50V D5XL11 P5MM 85C
C602 605 610 612 616 619 624 627 669	H01-CEMFC0106AH-7	CAP ELEC 10UF 16V M 5X11 P5MM SHL
C1 607 608 609 614 615 617 622 623 625 681 682 683	CZJII0101BE-2	CCCFMIC 100P0F +5% -5% 50.0V NP0 0603
C686 687	CZKII0103BC-5	CAP CHIP 10N0F +10% -10% 50.0V X7R 0603
C684	CZKII0223BC-6	CAP CHIP 22N0F +10% -10% 50.0V X7R 0603
C665 666 676 679	CZZFI0104BF-8	CAP CHIP 100N0F +80% -20% 16.0V Y5V 0603
C673 674 675	CZJII0101BE-2	CCCFMIC 100P0F +5% -5% 50.0V NP0 0603
C653	CZJII0181BE-0	CCCFMIC 180P0F +5% -5% 50.0V NP0 0603
C652	CZKII0561BC-8	CAP CHIP 560P0F +10% -10% 50.0V X7R 0603
C2 634 657	CZZFI0104BF-8	CAP CHIP 100N0F +80% -20% 16.0V Y5V 0603
<i>Semiconductors</i>		
Q201 202	H01-TRKTA107MNA-7	TR-SLPSWA KRA107M P
IC1 2	H01-ICPC17T10B1-2	IC PHOTOCOUPLER PC-17T1 DIP4 KODENSHI
D207 208 209	H01-DS0KDS160NB-4	D-SLP KDS160 85.0V 100MIOA
D601 602 603 604	H01-DS1S50094NB-A	D-SLP 1SS355 35.0V 225MIOA
IC612	H01-ICBU4053BB4-7	IC BU4053BCF SOP16 ANALOG MPX/DEMPX
IC609	H01-ICBU4094BD3-2	IC CMOS BU4094BF SOP16
IC604	H01-ICLM01232D3-7	IC VIDEO SW MM1232 SOP16
IC601 602 603	H01-ICNJM2296D3-7	IC-LINEAR NJM2296
Q601 602	H01-TRKTA1504ND-7	TRANSISTOR PNP KTA1504Y(S)SOT-23
D1 10 2 3 4 5 6 7 8 9	H01-DS05GBUSCNB-A	DIODE PG05GBUSC
IC611	H01-ICBU4094BD3-2	IC CMOS BU4094BF SOP16
IC608	H01-ICLM01232D3-7	IC VIDEO SW MM1232 SOP16
IC614	H01-ICMM1501XDL-A	IC-VIDEO SW MM1501XNRE SOT-26B

Ref Designator	Part Number	Description
<b>VIDEO PCB</b>		
IC605 606 607	H01-ICNJM2296D3-7	IC-LINEAR NJM2296
IC613	H01-ICTSH95IDB4-6	IC-VIDEOPROC TSH95ID VIDEO AMPLIFIER
Q603 604	H01-TRDTA114YNI-9	TR-SSD DTA114YKA P 10K0 OHM 47K0 OHM
Q611 612 613	H01-TRDTC114YNS-1	TRANSISTOR NPN DTC114YK (S) SPT/RHOM
<i>Resistors</i>		
R636 637 638	RS3AD0102NA-3	RMGCFMIC 1K0 OHM +5% 62MI5W
R251 606 611 612 616 621 622 626 631 632	RS3AD0103NA-1	RMGCFMIC 10K0 OHM +5% 62MI5W
R639	RS3AD0123NA-6	RMGCFMIC 12K0 OHM +5% 62MI5W
R673 674	RS3AD0222NA-4	RMGCFMIC 2K2 OHM +5% 62MI5W
R651	RS3AD0223NA-2	RMGCFMIC 22K0 OHM +5% 62MI5W
R247	RS3AD0271NA-2	RMGCFMIC 270R0 OHM +5% 62MI5W
R646	RS3AD0331NA-A	RMGCFMIC 330R0 OHM +5% 62MI5W
R671 675	RS3AD0333NA-6	RMGCFMIC 33K0 OHM +5% 62MI5W
R240	RS3AD0392NA-1	RMGCFMIC 3K9 OHM +5% 62MI5W
R244 248	RS3AD0470NA-7	RMGCFMIC 47R0 OHM +5% 62MI5W
R246	RS3AD0471NA-5	RMGCFMIC 470R0 OHM +5% 62MI5W
R242 243	RS3AD0473NA-1	RMGCFMIC 47K0 OHM +5% 62MI5W
R672 676	RS3AD0680NA-7	RMGCFMIC 68R0 OHM +5% 62MI5W
R3	RS1AD0750NA-6	RES CHIP 750HM 1% 1/16W 0603
R241	RS3AD0104NA-A	RMGCFMIC 100K0 OHM +5% 62MI5W
R1	RS3AD0361NA-1	RES CHIP,360 OHM,1/16W,+/-5%,0603
R641 642 643 658 668 711 713 718	RS3AD0102NA-3	RMGCFMIC 1K0 OHM +5% 62MI5W
R656 657 666 669	RS3AD0103NA-1	RMGCFMIC 10K0 OHM +5% 62MI5W
R661 667	RS3AD0122NA-8	RMGCFMIC 1K2 OHM +5% 62MI5W
R644	RS3AD0123NA-6	RMGCFMIC 12K0 OHM +5% 62MI5W
R2 647 649	RS1AD1580NA-0	RES CHIP 1580HM 1% 1/16W 0603
R662 712 715 717 719	RS3AD0154NA-6	RMGCFMIC 150K0 OHM +5% 62MI5W
R659 665	RS3AD0223NA-2	RMGCFMIC 22K0 OHM +5% 62MI5W
R654 655	RS3AD0330NA-1	RMGCFMIC 33R0 OHM +5% 62MI5W
R607 608 609 617 618 619 627 628 629	H01-RS1AD78R7NA-9	RES CHIP 78.7OHM 1% 1/16W 0603
R600 601 602 603 604 605 613 614 615 623 624 625 633 634 635	RS1AD0750NA-6	RES CHIP 750HM 1% 1/16W 0603
R714 716	RS3AD0753NA-6	RES CHIP 75K 1/16W +-5% 0603.
R663	RS3AD0822NA-2	RMGCFMIC 8K2 OHM +5% 62MI5W
<i>Miscellaneous</i>		
NJ611 612 613 614	H01-SQJW2350SNN-A	JACK PHONE 3.6 EP-1401A 1P BK
NJ601 602 603 604 605 606 607 608	H01-SORA11Y00NN-5	JACK RCA+S VIDEO C5016031DN
N601	H01-WN04AB100WH-8	CONN WAFER 2.0MM 4P 35237-0410 WHT
P603	H01-WN10SB00000-0	CONNECT 2.0MM 10P GIL-S-10P-S2T2-EF
N602	H01-WN19AB00000-9	CONN 2.0MM 19 MA R NAT SOCKET MOLEX 35237-1910 0 0
J600	RS3AD0000NA-0	RMGCFMIC 0 OHM +0% 62MI5W
<b>FAROUDJA PCB</b>		
<i>Capacitors</i>		
C123 129 140 162 164 166 170 188 237 240 241 248 249	CEMFC01062S-4	CE 10UF 16V M 5X11 SHL P2.5MM
C102 130 131 132 133 134 207 210 220 239	CEHFC01075E-1	CE 100UF +20% 16.0V D6.3XL11 P5MM 85C
C158 234 235 236	CEMFC04762S-4	CE 47UF 16V M 5X11 SHL P2.5MM
C196 198	CEHIC01055E-6	CE 1UF +20% 50V D5XL11 P5MM 85C
C205 233	CEMFC0226MN-A	CAP ELEC 22UF 16V M 5X11 P2.5MM
C242 244 246	CEHEC0477MN-A	CE 470U0F +20% 10.0V 6.3X11 85C ELITE
C175 176	CSDIE080ABG-7	CAP CHIP FORM 8PF 50V +/-0.25 0603 COG
C191 192	CZJII0330BE-9	CCCFMIC 33P0F +5% -5% 50.0V NP0 0603
C200	CZKII0102BC-7	CAP CHIP 1N0F +10% -10% 50.0V X7R 0603
C165 167 171	CZKII0103BC-5	CAP CHIP 10N0F +10% -10% 50.0V X7R 0603

Ref Designator	Part Number	Description
<b>FAROUDJA PCB</b>		
C183 185 238	CZKII0152BC-3	CAP CHIP 1N5F 50V X7R K 0603
C184	CZKII0391BC-7	CAP CHIP 390PF 50V X7R K 0603
C112 113 114 115 116 193	CTK4I0106ZN-0	TANT CAP CASE-B 10UF +10%-10% 20V 3528
C100 101 103 104 105 106 107 108 109 110 117 118 119 120 121 122 124 125 126 127 128 138 139 144 156 157 179 180 182 195 199 208 215 216 223 224 225 228 230 243 245 247	CZZFI0104BF-8	CAP CHIP 100N0F +80% -20% 16.0V Y5V 0603
C186	CZZFI0224BF-9	CAP CHIP 220NF 16V Y5V +80%-20% 0603
C159 160 161	CZJII0101BE-2	CCCFMIC 100P0F +5% -5% 50.0V NPO 0603
C137 154	CZJII0121BE-7	CAP CHIP 120PF 50V J NPO 0603
C136 153	CZJII0151BE-9	CAP CHIP 150PF 50V J NPO 0603
C142	CZJII0390BE-2	CAP CHIP 39PF 50V CH J NPO 0603
C146 150	CZJII0471BE-2	CCCFMIC 470P0F +5% -5% 50.0V NPO 0603
C168	CZKII0102BC-7	CAP CHIP 1N0F +10% -10% 50.0V X7R 0603
C163	CZKII0103BC-5	CAP CHIP 10N0F +10% -10% 50.0V X7R 0603
C177	CZKII0152BC-3	CAP CHIP 1N5F 50V X7R K 0603
C111 190	CTK4I0106ZN-0	TANT CAP CASE-B 10UF +10%-10% 20V 3528
C143 155 178 181 187 189 194 197 211 212 213 214 217 218 219 221 222 226 227 229 232	CZZFI0104BF-8	CAP CHIP 100N0F +80% -20% 16.0V Y5V 0603
C169	CZZFI0105BF-6	CAP CHIP 1UF 16V Y5V +80% -20% 0603
C172 173 174	CZZFI0224BF-9	CAP CHIP 220NF 16V Y5V +80%-20% 0603
<i>Semiconductors</i>		
Q106 107	H01-TRDTC114YNI-5	TR-SSD DTC114YKA N 10K0 OHM 47K0 OHM
D101 102 103	H01-DS1S50094NB-A	D-SLP 1SS355 35.0V 225MIOA
Q100 101 104	H01-TR2SA933ANW-2	TR-SLPLF 2SA933ASR P -3.0A -20V
IC15	H01-ICBU4053BB4-7	IC BU4053BCF SOP16 ANALOG MPX/DEMPX
IC13	H01-ICBU4094BD3-2	IC CMOS BU4094BF SOP16
IC11	H01-ICFLI2300NN-2	IC VIDEO ENHANCER FLI2300 PQFP-208
IC12	H01-ICK4S6432I6-1	IC 64M SDRAM K4S643232F-TC60/TC70
IC14	H01-ICMM1623XDA-7	IC VIDEO DRIVER MM1623X SOP-28D
IC10	H01-ICVPC3230NN-8	IC VIDEO DECODER VPC3230D
IC16	H01-ICPJCW3X3DG-8	IC VOLTAGE REGULATOR PJ1117CW-3.3 3.3V SOT-223
IC17	H01-ICPJCW1X8DG-0	IC VOLTAGE REGULATOR PJ1117CW-1.8 1.8V SOT-223
<i>Resistors</i>		
R129	RS1AD1870NA-2	RES CHIP 187 OHM 1/16W 1% 0603
R104 108	RS3AD0101NA-5	RMGCFMIC 100R0 OHM +5% 62MI5W
R115 125 126 134 135	RS3AD0103NA-1	RMGCFMIC 10K0 OHM +5% 62MI5W
R148 149 160	RS3AD0104NA-A	RMGCFMIC 100K0 OHM +5% 62MI5W
R128	RS3AD0105NA-8	RES CHIP 1M 1/16W +5% 0603
R101 102 113 114	RS3AD0151NA-1	RMGCFMIC 150R0 OHM +5% 62MI5W
R123 124	RS3AD0470NA-7	RMGCFMIC 47R0 OHM +5% 62MI5W
R105	RS3AD0511NA-8	RMGCFMIC 510R0 OHM +5% 62MI5W
R118 151	RS3AD0750NA-1	RMGCFMIC 75R0 OHM +5% 62MI5W
R162	RS3AD0101NA-5	RMGCFMIC 100R0 OHM +5% 62MI5W
R119 120 121 141 142 145 146 147	RS3AD0102NA-3	RMGCFMIC 1K0 OHM +5% 62MI5W
R127 136 137 138 139 140	RS3AD0103NA-1	RMGCFMIC 10K0 OHM +5% 62MI5W
R122 143 144	RS3AD0470NA-7	RMGCFMIC 47R0 OHM +5% 62MI5W
R133	RS3AD0472NA-3	RMGCFMIC 4K7 OHM +5% 62MI5W
R106 107 109 110 116 117 130 131 132 152 153 157 158 159	RS3AD0750NA-1	RMGCFMIC 75R0 OHM +5% 62MI5W
RA10 11 12 13 14 15 16 17 18 19 20 21 22 23	RS3AY0470NA-2	RCA 47R0 OHM +5% 62M15W 4
R161	RS3AD0471NA-5	RMGCFMIC 470R0 OHM +5% 62MI5W
<i>Miscellaneous</i>		
X100	H01-OSX13M5HZ00-4	CRYSTAL 13.5MHz WO0IN

Ref Designator	Part Number	Description
<b>FAROUDJA PCB</b>		
X101	H01-OSX20M25H00-2	CRYSTAL 20.25MHz 13PF WOOIN
K101 102	H01-RLL0517811A-A	RELAY D3009(1-1462033-4)
P104	H01-WG02SB81500-6	WIRE ASS'Y 2.0MM 2P 150MM RED UL1007#26
P103	H01-WG04SB82800-7	WIRE ASS'Y 2.0MM 4P 280MM RED UL1007#26
P101	H01-WG05SB84700-4	WIRE ASS'Y UL1007#26 470MM 5P 2.0MM STR WHT
P102	H01-WN20SC00000-6	CONN WAFER 2.54MM TSS-254-20P
P100	H01-WN30SC00000-2	CONN WAFER 2.54MM TSS-254-30P
L111 112 113	H01-FB121201208-2	FERRITE BEADS FCM2012K-121T08 120OHM 2012
L105 106 107 108 109 114 115 116 120 121 123 124 125 126 127	H01-FB121201208-2	FERRITE BEADS FCM2012K-121T08 120OHM 2012
L101	H01-LS1002102CN-9	INDUCTOR COIL FCI2012-100K 100UH 0805
L102 103	H01-LS2U22102CN-0	INDUCTOR COIL FCI2012-2R2K 2U2H 0805
L100 104	H01-LS4U72102CN-4	INDUCTOR COIL FCI2012-4R7K 4U7H 0805
<b>CONNECTOR BD</b>		
N107 108 509 602	H01-WN19SB00000-6	CONN 2.0MM 19 MA ST NAT MOLEX 35336-1910 0 0
N203 208 501	H01-WN19AB00000-9	CONN 2.0MM 19 MA R NAT SOCKET MOLEX 35237-1910 0 0
N104 502 517 601	H01-WN04SB100WH-5	CONN WAFER 2.0MM 4P 35336-0410 WHT
N205	H01-WN14AB100WH-4	CONN WAFER 2.0MM 14P 35237-1410 WHT
N503	H01-WN14SB100WH-1	CONN WAFER 2.0MM 14P 35336-1410 WHT
<b>MECHANICAL/MISCELLANEOUS</b>		
	H01-RP42T100BNN-A	POSISTOR P42T8D100BW16
	H01-SWA2B21PDA&-7	SW PUSH POWER SDDL15700
	H01-TXPWMD05B0-5	MN X'FORMER AVR7300 120V TRANSFORMER
	H01-WF15S1105FU-0	WIRE FFC DHCDF-15/110-P1.25-AT
	H01-WF23S4505FU-2	WIRE FFC DHCDF-23/450-P1.25-AT
	H01-WS0266005FN-8	WIRE ASS'Y UL1533/2547/1007#26 600MM 2.0MM 10P STR
	H01-ZMB01S00100-5	BKT HEADPHONE JACK
	H01-ZMB01S02200-9	SPRING PLATE GND C5212 0.2T
	H01-ZMD05S02A00-1	AL DOOR AVR7300
	H01-ZMC11S00300-2	AL PANEL AVR430/630
	H01-ZMC11S06A00-3	SPRING STOPPER AVR430/630
	H01-ZMC11S12A00-8	CAP BUTTON STAND-BY AVR430/630
	H01-ZMC12S09A00-4	BKT HEATSINK
	H01-ZMC12S20A00-2	BADGE AL HARMAN/KARDON SILVER
	H01-ZMD05S03A00-2	HEATSINK 3CH AVR7300
	H01-ZMD05S04A00-3	HEATSINK 4CH AVR7300
	H01-ZMD05S07A00-6	CHASSIS FRONT AVR7300
	H01-ZMD05S08A00-7	COVER TOP AVR7300
	H01-ZMD05S08B00-9	BKT TRANS BOTTOM AVR7300
	H01-ZMD05S09A00-8	BKT TOP
	H01-ZMD05S10A00-8	BKT SIDE
	H01-ZMD05S11A00-9	PANEL REAR AVR7300US
	H01-ZMD05S12AYE-8	STUD STANDOFF HEX M4X0.7 6X15H
	H01-ZMD05S13A00-0	CHASSIS MAIN AVR7300
	H01-ZMD05S13AYE-9	STANDOFF HEX M4X0.7 6X55H
	H01-ZMD05S14AYE-A	STANDOFF HEX M4X0.7 6X34H
	H01-ZMD05S15A00-2	BKT SUPPLY
	H01-ZMD05S16A00-3	BKT HINGE AVR7300
	H01-ZPC1004GASG-0	BUTTON 7 KEY
	H01-ZPC1018GART-7	FILTER VFD
	H01-ZMGEN00GAGY-0	AL LOGO BADGE TOP
	H01-ZPD0515GAMW-A	VOLUMN KNOB AVR7300
	H01-ZPD0316GASG-A	COVER KNOB
	H01-ZPD0317GACR-4	CAP KNOB VOLUMN
	H01-ZPD0501GAGY-9	FRONT PANEL AVR7300
	H01-ZMD05S17A00-4	AL DOOR PANEL AVR7300
	H01-ZPD0503GAGY-5	FRAME DOOR L
	H01-ZPD0504GAGY-3	FRAME DOOR R
	H01-ZPD0522GABT-3	WINDOW DISPLAY AVR7300



Ref Designator	Part Number	Description
	H01-ZVC11DWT100-3	TAPE DOOR
	H01-ZVC11DWT200-5	TAPE PANEL
	H01-ZVC11GEAR01-A	DAMPER GEAR DP120
	H01-ZVC11TUNE01-7	TUNER MODULE KST-MB011MW0-81 US
	ZFNR19720SB-5	RUBBER FOOT 19.7X19.7X2T BK
	ZKC1222HA00-2	LABEL RISK
	ZKC1229HA00-7	LABEL DATE
	ZKC1281HA00-9	LABEL QC CHECK
	ZKD0530HA00-8	LABEL SERIAL AVR7300US
	ZKD0573HA00-9	LABEL BARCODE AVR7300 US
	ZKD0584HA00-0	LABEL LICENSE AVR7300 US
	ZKGEN97HA00-3	LABEL MAIN POWER REMIND
	H01-ZMC12S19A00-2	BKT AC INLET
	ZNSSM4045HZ-4	NUT M4 HEXAGON CIRCULAR EXTERNAL
	ZPD0503GAGY-7	BUTTON POWER
	ZPC1005GAGY-8	BUTTON 8 KEY
	ZPC1006GAWH-0	BUTTON STANDBY
	ZPC1007GAMW-9	INDICATOR STAND-BY
	ZPC1017GABK-6	HOLDER VFD AVR430/630
	ZPC1102GAMW-1	INDICATOR VIDEO 4
	ZPC1103GAGY-A	FOOT 50MM 15.8MM
	ZSMWM4008BZ-2	SCREW M.S M4X8 W/H ZN PLATED
	ZSTBM0318TZ-3	SCREW ST BH 3X18
	XY1N033M0DW-3	DOUBLE SIDE TAPE #Y-4615 (3M)
	ZSTBM3008BY-1	SCREW ST BH 3X8
	ZSTBM3010BB-5	SCREW ST BH 3X10
	ZSTBM3012BY-A	SCREW ST BH 3X12 PIVOT
	H01-ZMD05S19A00-6	BRACKET SHIELD LARGE
	ZSTGM3010BB-3	SCREW ST BH 3X10 GROUND
	ZWMC04810PZ-5	WASHER PLAIN 4
	ZSTWM3008BY-8	SCREW ST WPH 3X8
	ZSTWM4008BC-3	SCREW ST WPH 4X8 SILVER CHROM
	ZTB017030AA-4	CABLE TIE 100MM NYLON 6
	ZWF793008PO-5	WASHER FIBER 3 0.8T
	ZV4P00030TH-3	HEAT SHRINK TUBE L30MM*D4.0MM*T0.5MM
	ZWM623108SZ-2	WASHER SPRING 3
	H01-ZMD05HS0300-0	HEATSINK REG.TR AVR7300
	ZWM763109SZ-2	AC SPRING WASHER RT2250(PAV5005)
	ZWM803305PZ-1	WASHER PLAIN 3
	H01-ZMD05S15AYE-0	STUD STANDOFF HEX M4X0.7 6X71.6H
	H01-ZMD05S05A00-4	SHIELD FAROUDJA
	H01-WG318H8722B-2	WIRE ASS'Y 6.2MM 3P 720MM UL1617#18 STR BRN
	H01-WG02SG8282A-5	WIRE ASS'Y 7.92MM 2P 280MM
	ZSMCM4014BN-6	SCREW MC4X14 NI PLATED
	H01-ZMD05S20A00-6	SHIELD LARGE AVR7300
	ZQB0101AA00-4	SHIELD FOAM GASKET (WOORI)
	H01-FBB0102AA00-7	FCORE FERRIT MAGNET SRH9. 9X20. 0X5. 1+CASE W5
	H01-FBD0480BR00-2	FCORE CLAMP FILTER LF80BR W5 SRH 16X28X9
	H01-ZMD05S21A00-7	SHIELD SMALL AVR7300
	ZFNR1450300-A	RUBBER TOP

CS42528  
DSP PART IC13

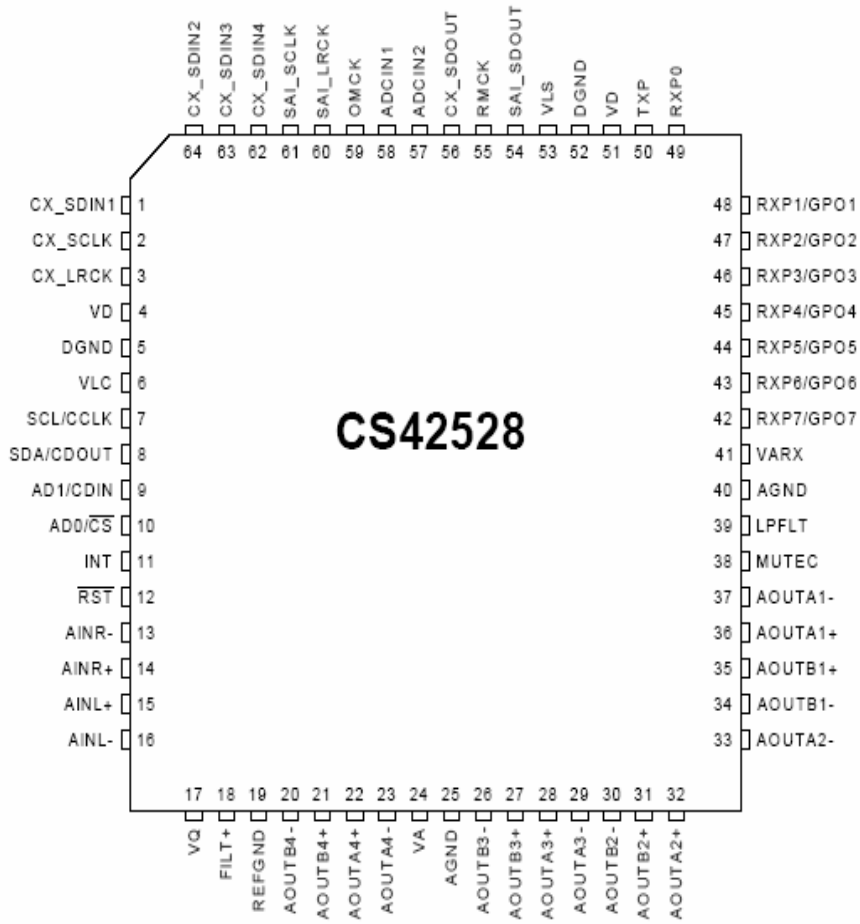

CS42528

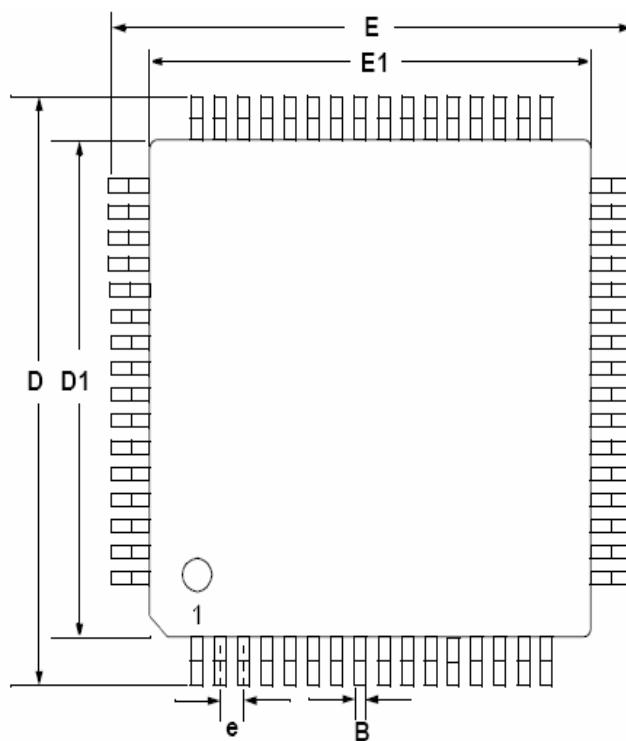

M74HCU04  
 DSP PART IC19, IC20

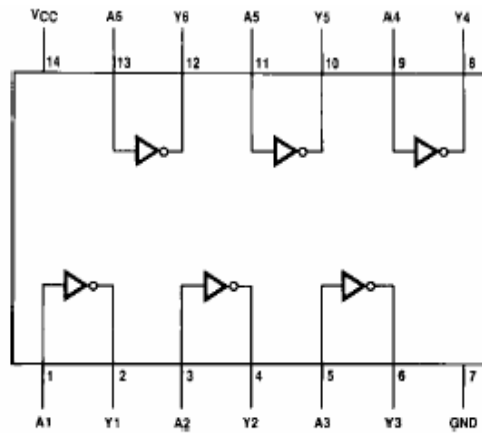
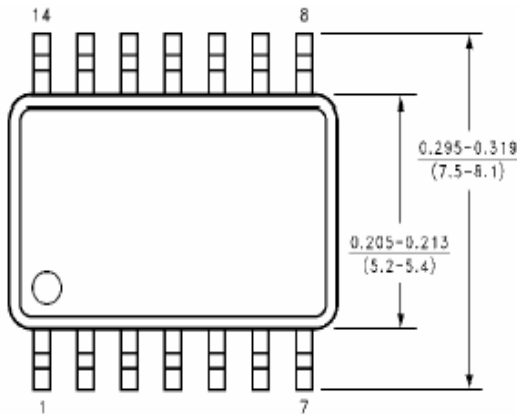

TC9273F  
 PROCESSOR APRT IC6, IC10

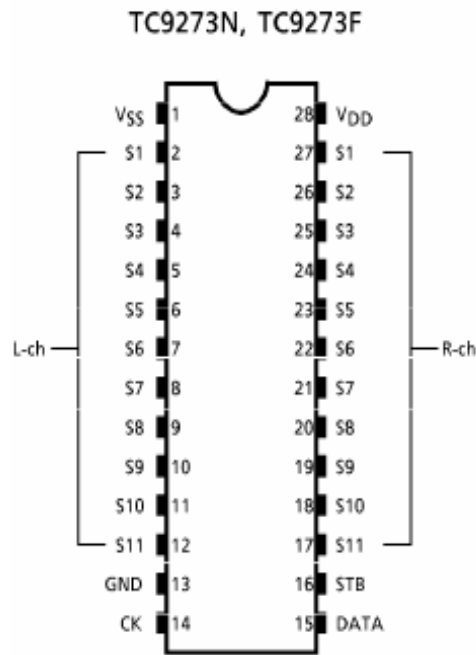
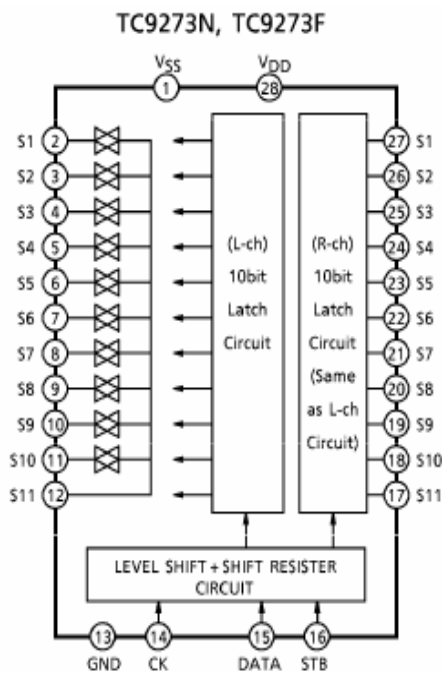

TC9273F

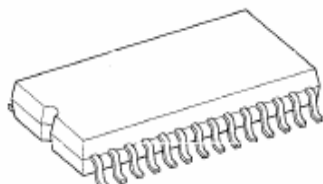

SOP28-P-450-1.27

TOTX179L  
 DSP PART NJ17  
 SUPPLY PART NJ86

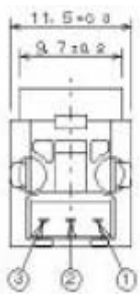

Pin connection

1. Output
2. GND
3. Vcc

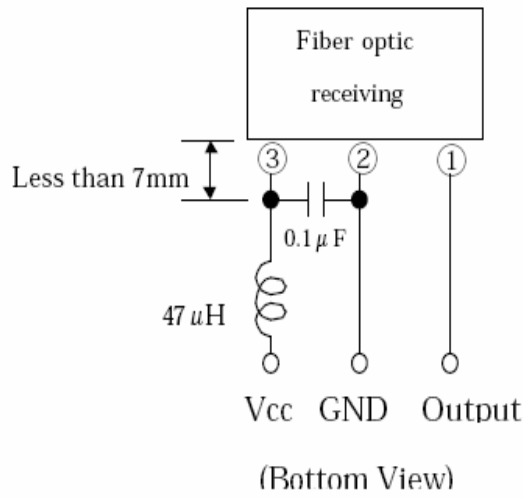

TORX179L  
 DSP PART NJ14, NJ15, NJ16  
 SUPPLY PART NJ87

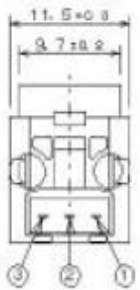

Pin connection

1. GND
2. Vcc
3. Input

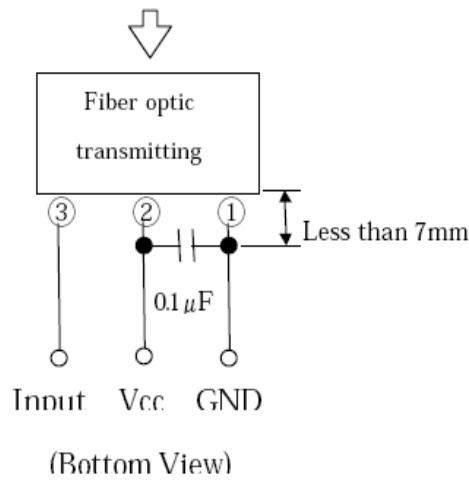

NJU6324M  
 DSP PART IC23



NJU6324XE

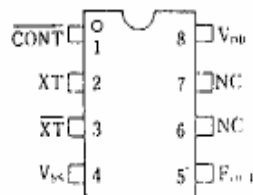

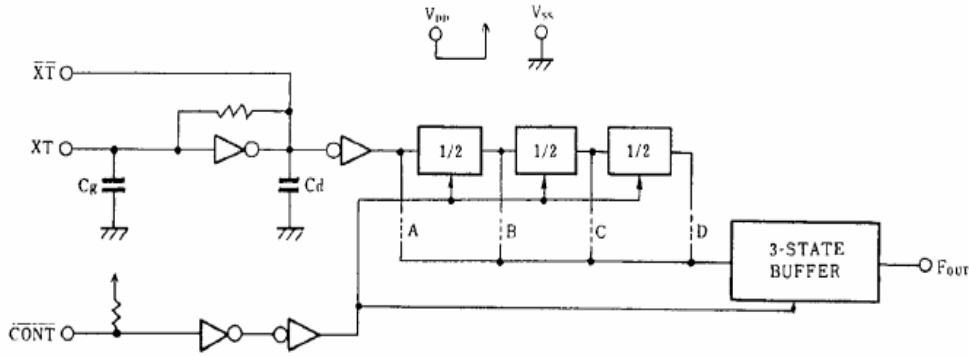

CS4391  
DSP PART IC26

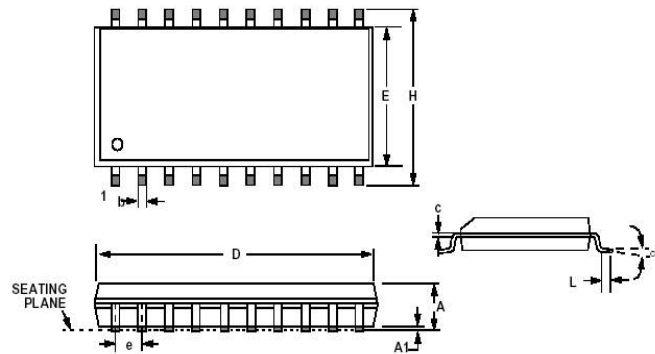
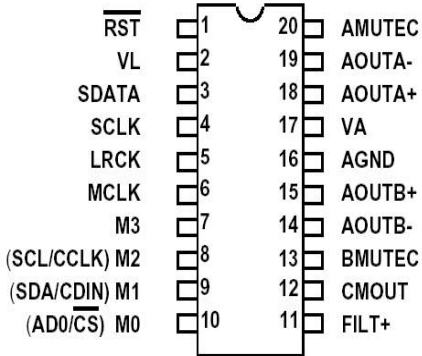

DIM	INCHES		MILLIMETERS	
	MIN	MAX	MIN	MAX
A	0.093	0.104	2.35	2.65
A1	0.004	0.012	0.10	0.30
B	0.013	0.020	0.33	0.51
C	0.009	0.013	0.23	0.32
D	0.496	0.512	12.60	13.00
E	0.291	0.299	7.40	7.60
e	0.040	0.060	1.02	1.52
H	0.394	0.419	10.00	10.65
L	0.016	0.050	0.40	1.27
$\infty$	0°	8°	0°	8°

MM1662H  
DSP PART IC24

LOW DROP VOLTAGE REGULATOR  
100mA REGULATOR

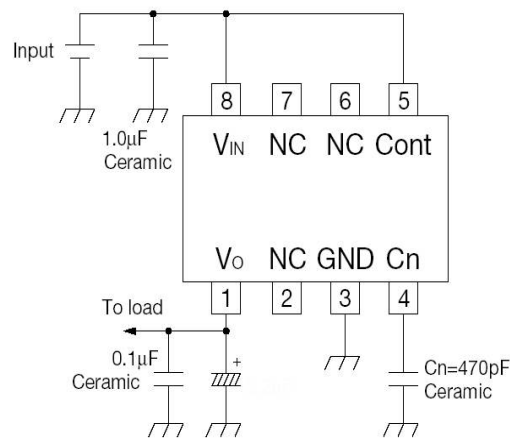
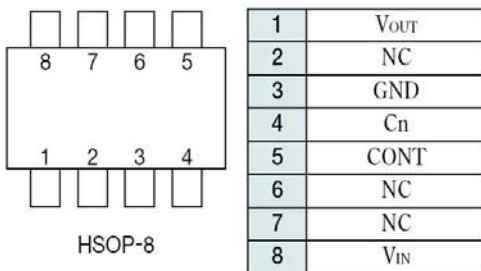

AT49LV8192A  
DSP PART IC804

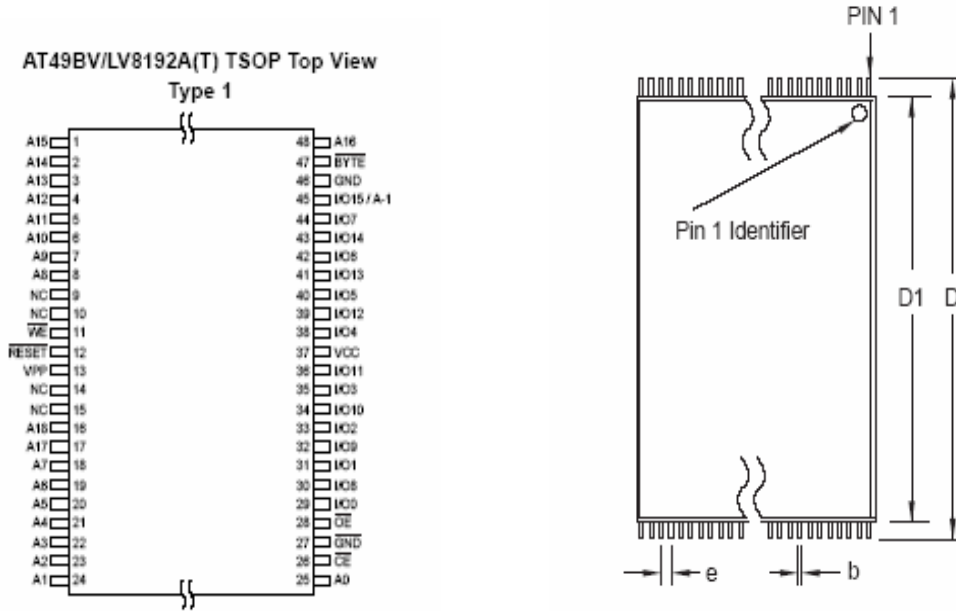

uPD70F3033BGF  
DSP PART IC12

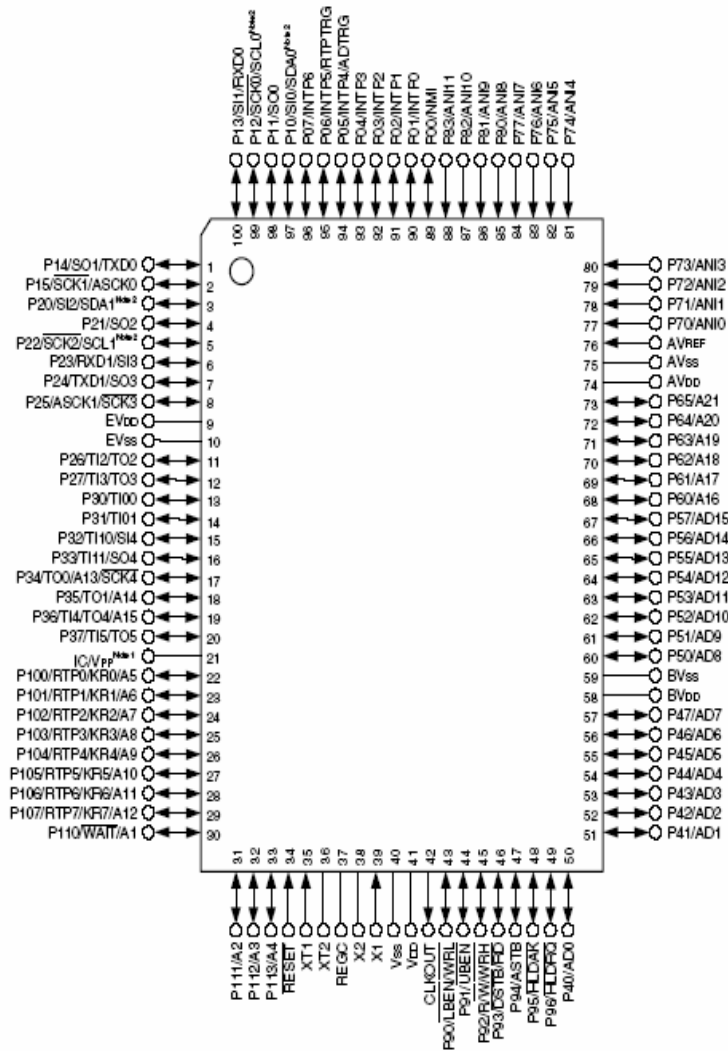

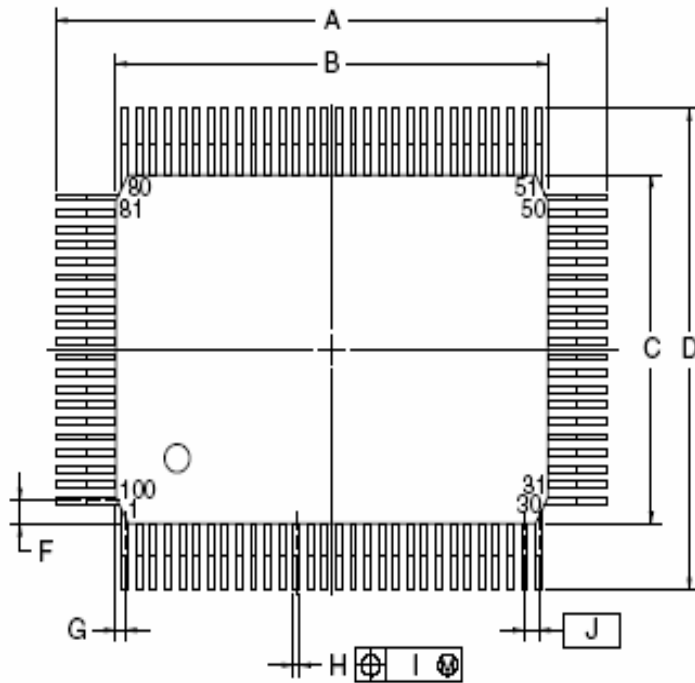

uPD70F3033BGF

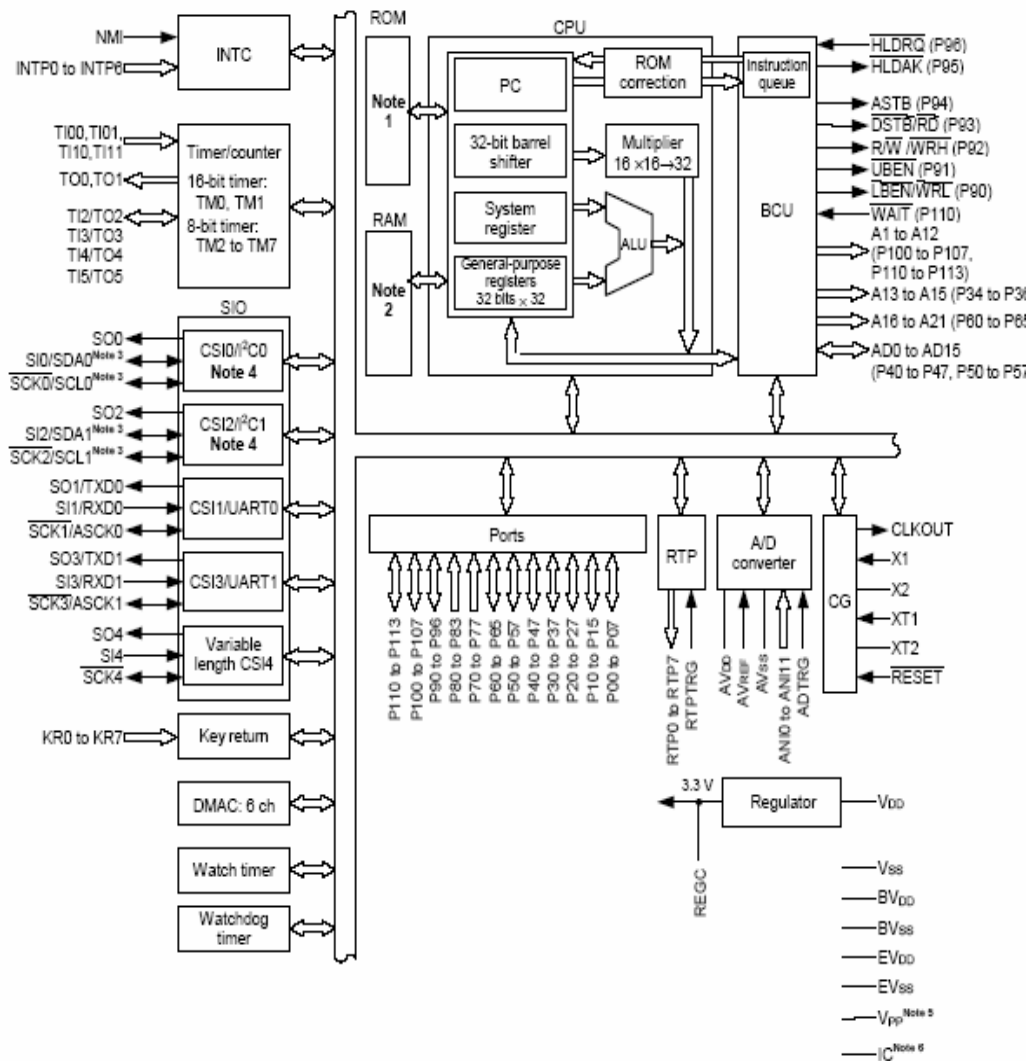

BU4094BF

DSP PART

VIDEO PART

FRONT PART

IC16

IC609, IC6

IC71

FAROUDJA PART IC13

MAIN PART

IC208

BU4094BCF

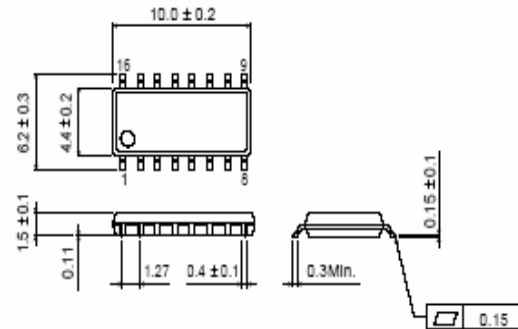
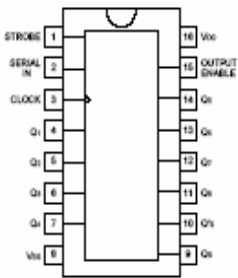

SOP16

VCOX 24M576HZ

DSP PART Y800

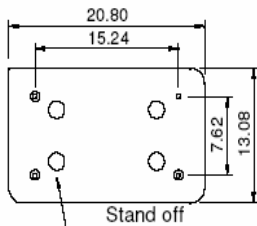
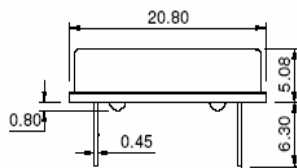

< 14 PIN DIP >

PIN	CONNECTION
# 1	INH or No Connection
# 7	Ground
# 8	Output
# 14	Vdc

BA033T

MAIN PART

SUPPLY PART

IC214

IC45

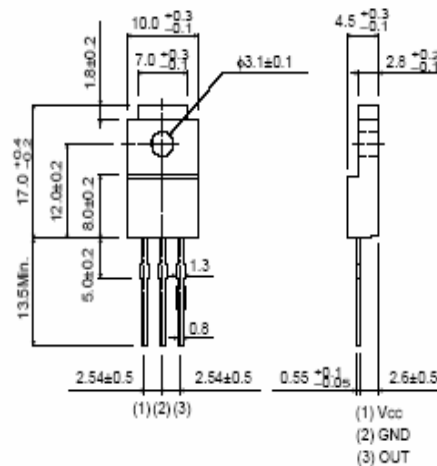
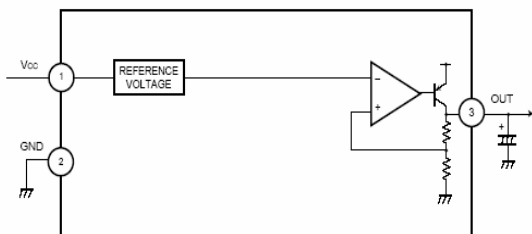



NJM2296M  
VIDEO PART

IC601, IC602, IC603, IC605, IC606, IC607

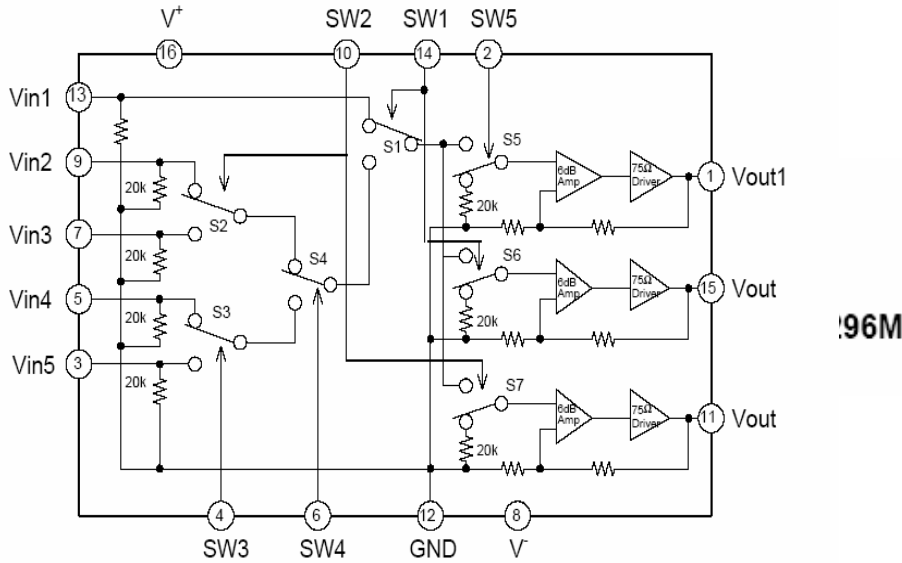

MM1510  
MAIN PART

IC2, IC201, IC202, IC203

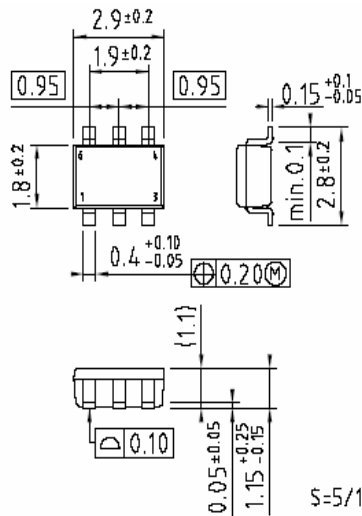
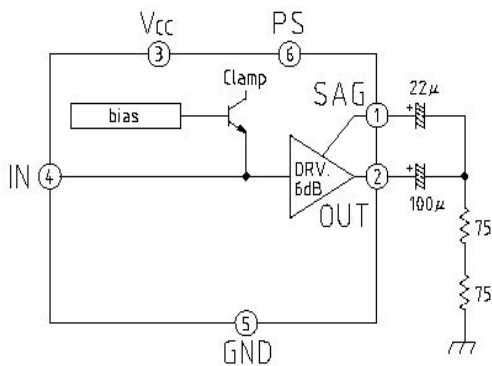

MM1501  
VIDEO PART

IC614

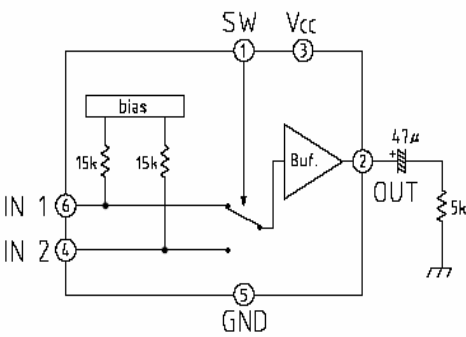

MAIN PART

IC1, IC204, IC205

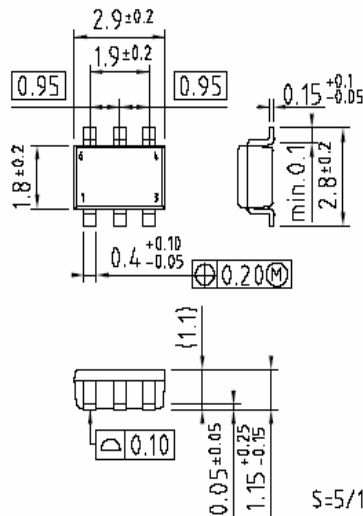

0 | - | 3=3/1

MM1511  
MAIN PART

IC206

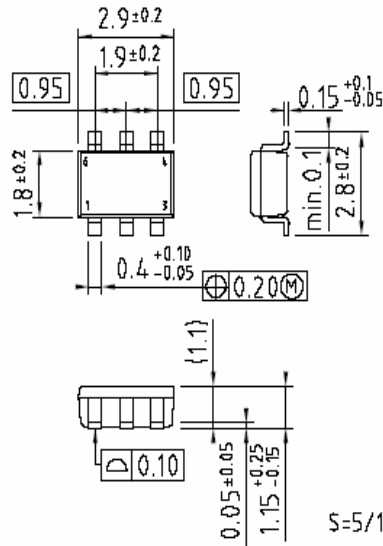
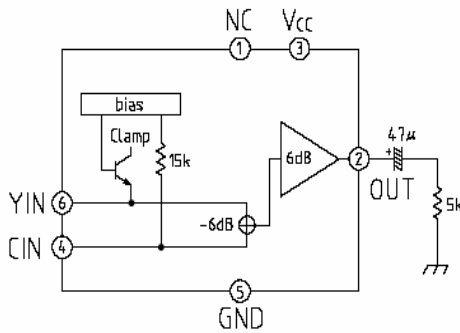

PHOTOCOUPLER PC-17T1

VIDEO PART

IC1, IC2

MAIN PART

IC219, IC220

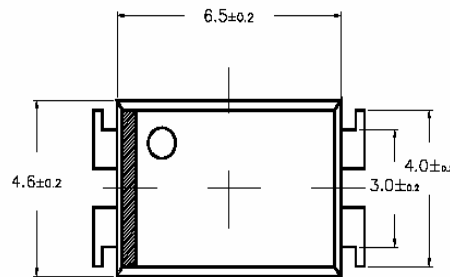
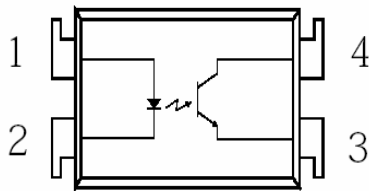

- PIN Connections**
1. Anode
  2. Cathode
  3. Emitter
  4. Collector

TC9162AF  
PROCESSOR

IC5, IC14

TC9162AF  
TC9163AF  
TC9164AF

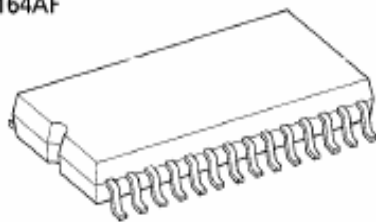

SOP28-P-450-1.27

PIN CONNECTION (TOP VIEW)

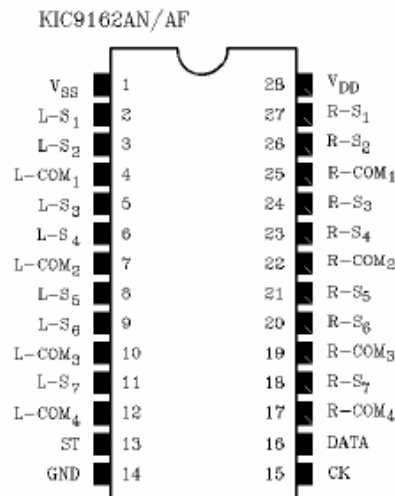

TC9163AF  
PROCESSOR IC3

TC9162AF  
TC9163AF  
TC9164AF

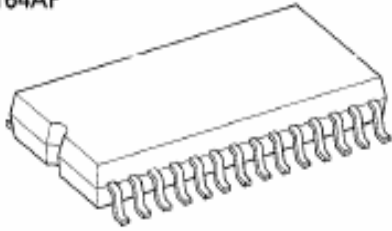

SOP28-P-450-1.27

KIC9163AN/AF

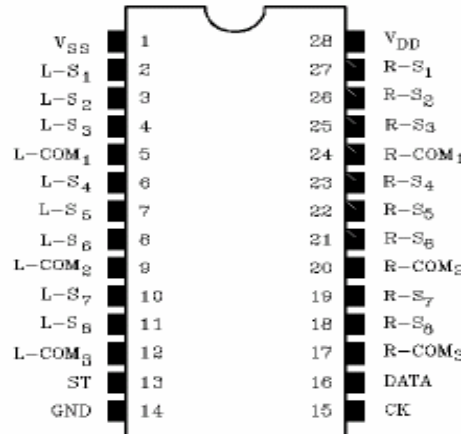

MM1232  
VIDEO PART IC604, IC608

MM1232

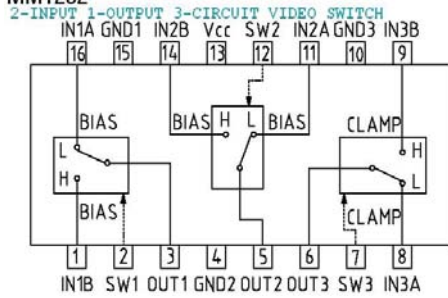

Control input truth table

SW	OUT
L	IN1A
	IN2A
	IN3A
H	IN1B
	IN2B
	IN3B

FLI2300 PQFP (VIDEO ENHANCER IC)  
 FAROUDJA PART IC11

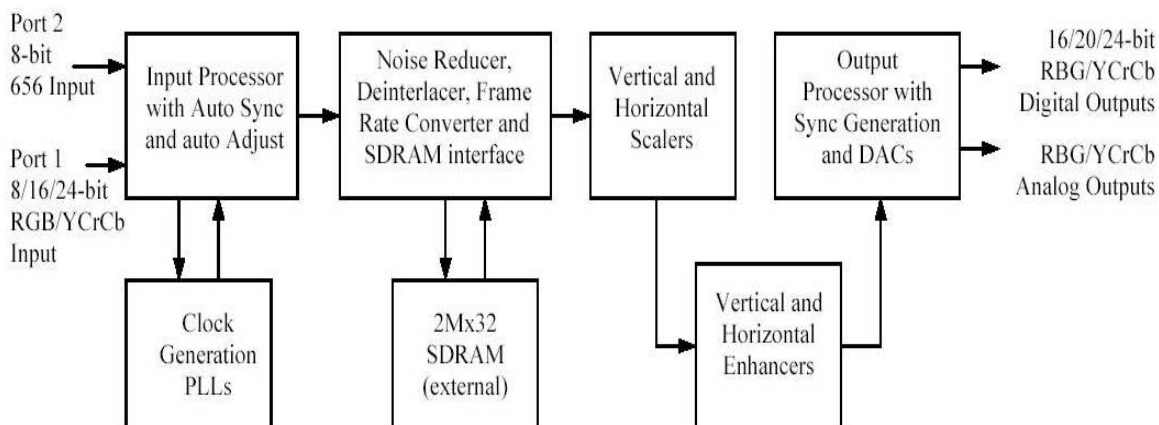
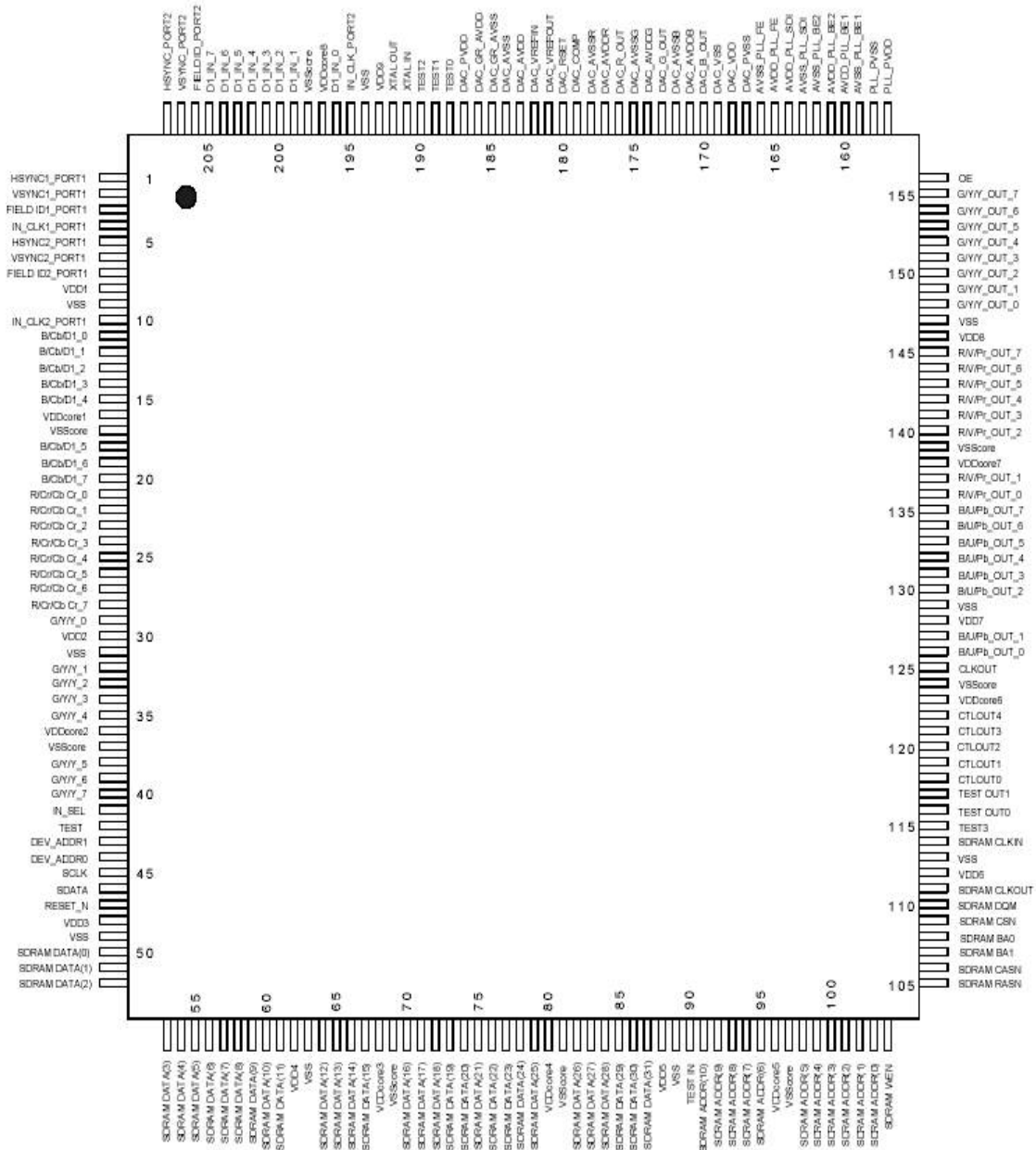

TC9273F  
PROCESSOR

IC6,IC10

PIN CONNECTION (TOP VIEW)

TC9273N, TC9273F

TC9273F

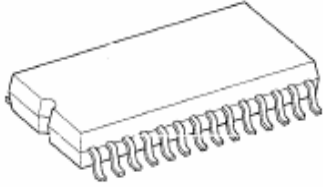

SOP28-P-450-1.27

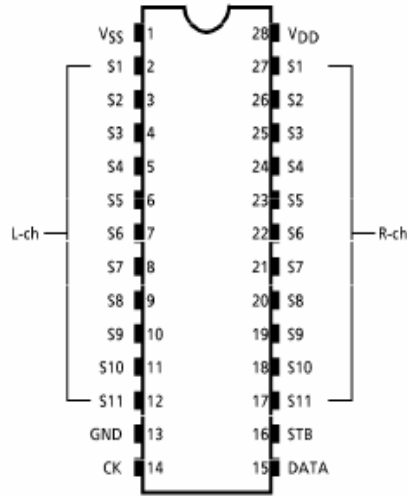

TC9482F  
PROCESSOR

IC19

TC9482F

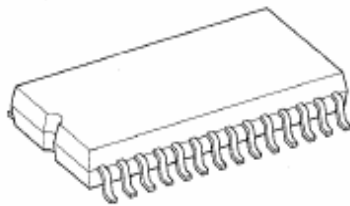

SOP28-P-450-1.27

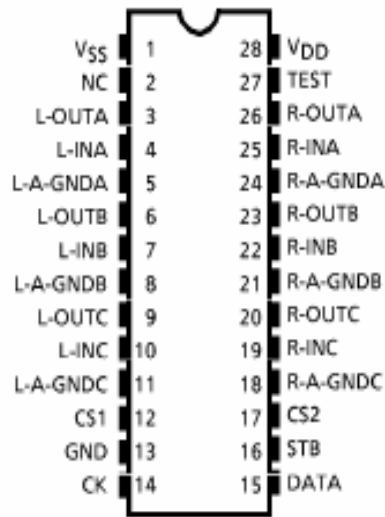

TC9481F  
PROCESSOR

IC28

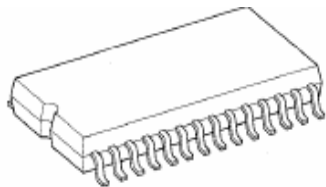

SOP28-P-450-1.27

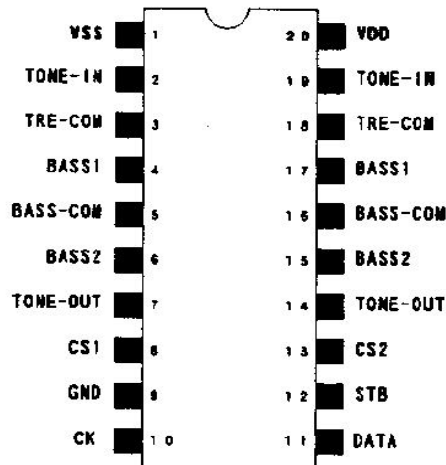

KIC9459F  
PROCESSOR IC2.IC18

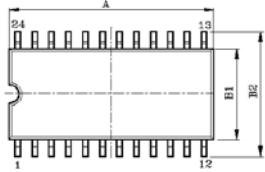
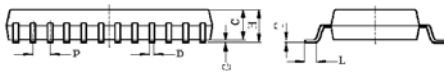

DIM	MILLIMETERS
A	16.0±0.2
B1	8.6±0.2
B2	11.8±0.3
C	2.0±0.2
D	0.40/0.1
G	0.1 +0.1/-0.05
H	2.2MAX
L	1.0±0.2
P	1.27
T	0.15 +0.1/-0.05

24PIN

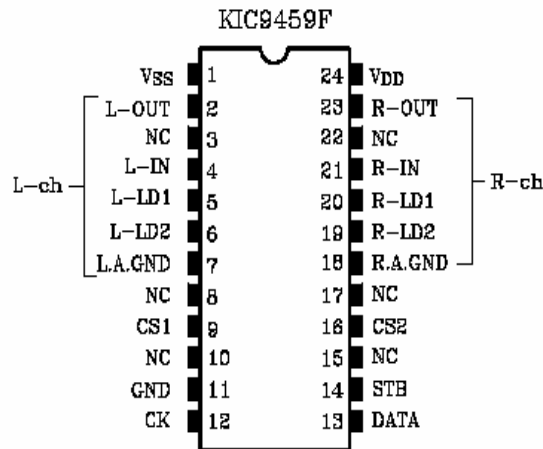

TSH95  
VIDEO PART IC613

SOP 16PIN

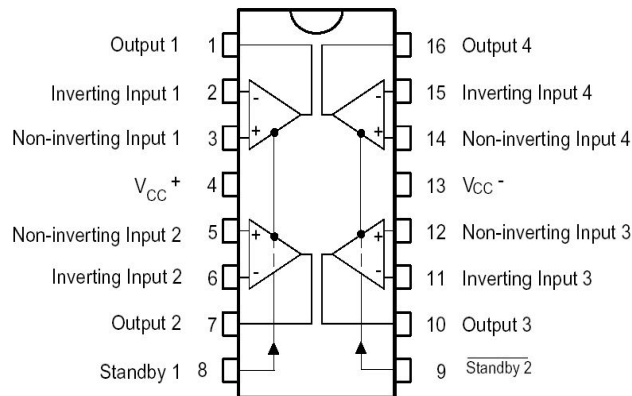

20-PIN PLASTIC SSOP (7.62 mm (300))

uPD4721  
SUPPLY PART IC43

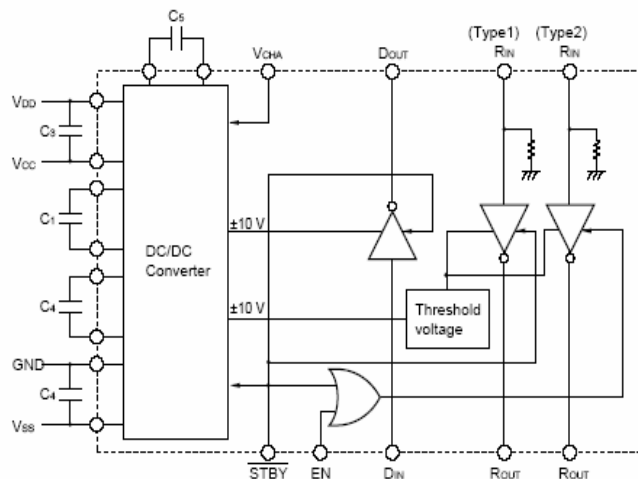
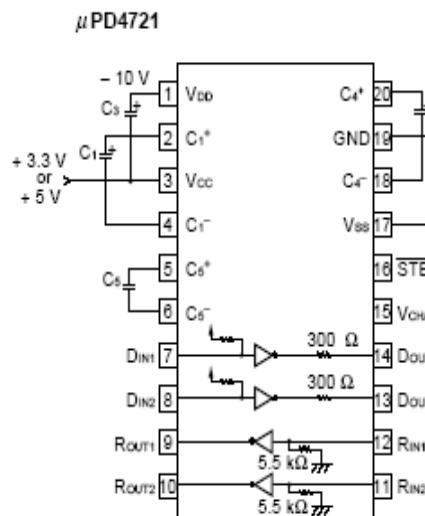
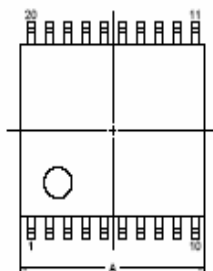

K4S161622D-TC80

DSP PART IC14

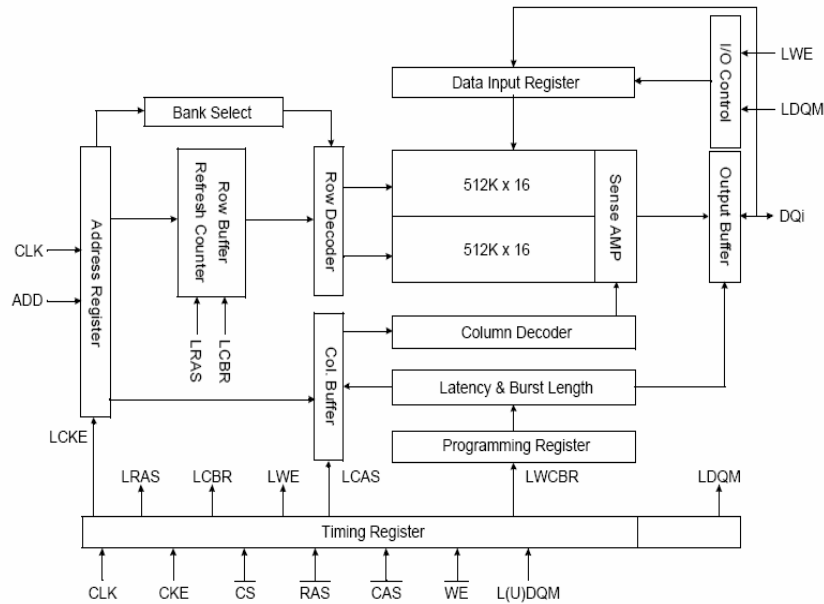
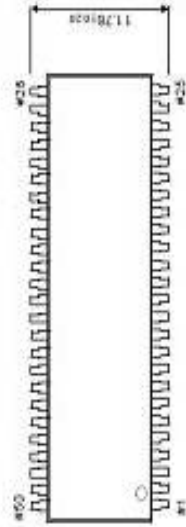
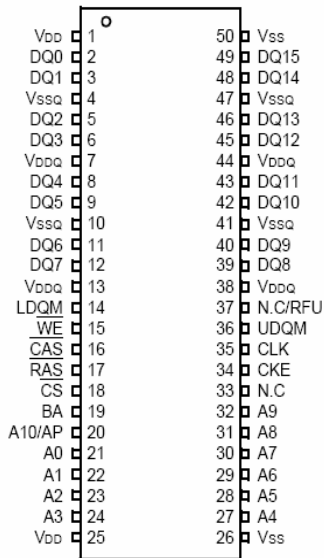

M24C04 DSP PART

IC22

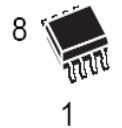
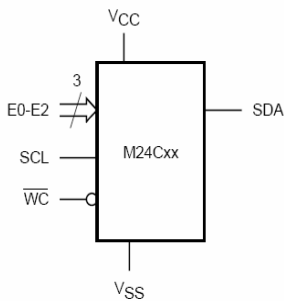

SO8 (MN)  
150 mil width

M24Cxx

16Kb/8Kb/4Kb/2Kb/1Kb

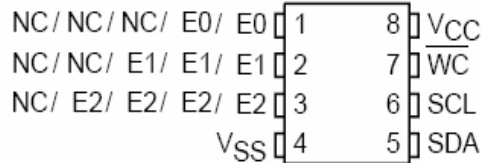

E0, E1, E2	Chip Enable
SDA	Serial Data
SCL	Serial Clock
WC	Write Control
VCC	Supply Voltage
VSS	Ground

74VHCT244A

DSP PART

IC17, IC18, IC25

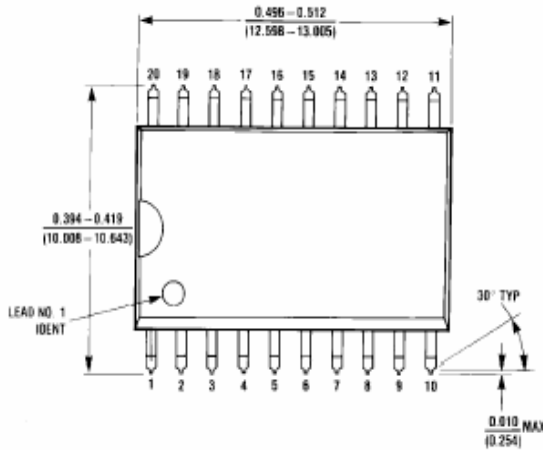
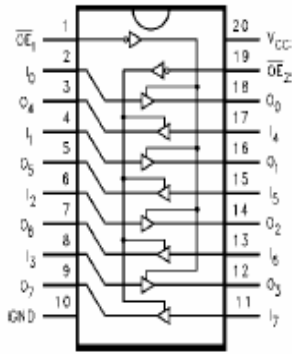

NJM2068M

DSP PART

IC31 ~ IC50

PROCESSOR PART

IC1.IC4.IC7.IC8.IC9.IC11.IC12.IC13.IC15.IC16.IC17.IC20  
IC21.IC23.IC24.IC25.IC26.IC27,IC29,IC30

**PIN FUNCTION**  
1.A OUTPUT  
2.A -INPUT  
3.A +INPUT  
4.V<sup>-</sup>  
5.B -INPUT  
6.B -INPUT  
7.B OUTPUT  
8.V<sup>+</sup>



NJM2068D  
NJM2068M  
NJM2068V



NJM2068M

LC74763M

VIDEO PART

IC209

[LC74763M]

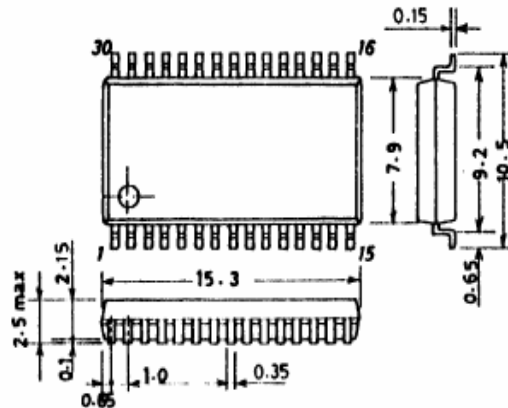

SANYO: MFP30S

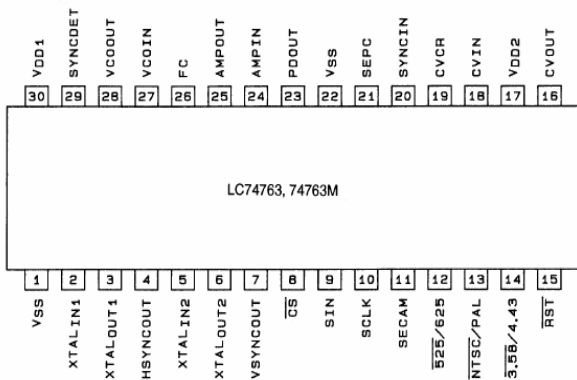

Top View





KIA78R08API  
DSP PART

IC21

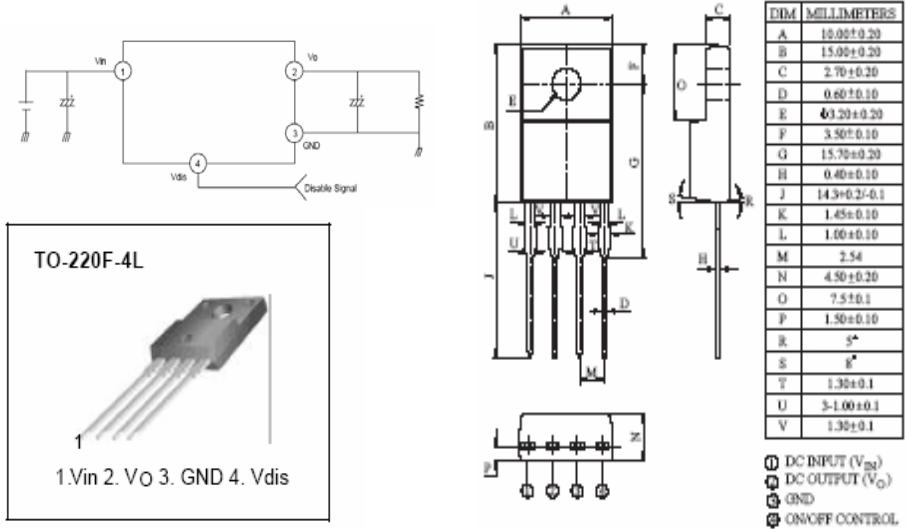

RPM6938-RSIP-A3  
FRONT PART

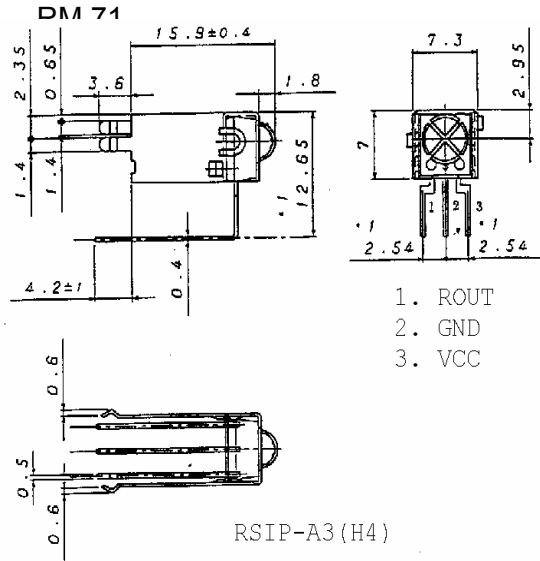

BU4053BC  
VIDEO PART  
FAROUDJA PART

IC612  
IC15

DSP PART

IC5

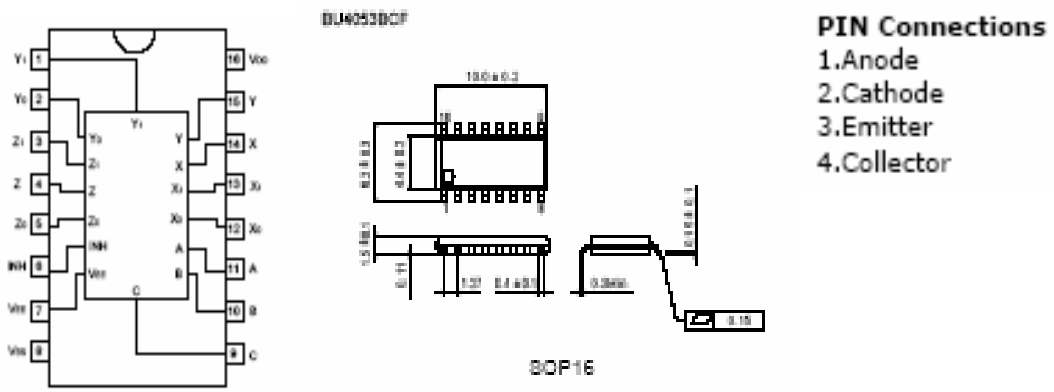

CS5361  
DSP PART

IC27, IC28, IC29, IC30

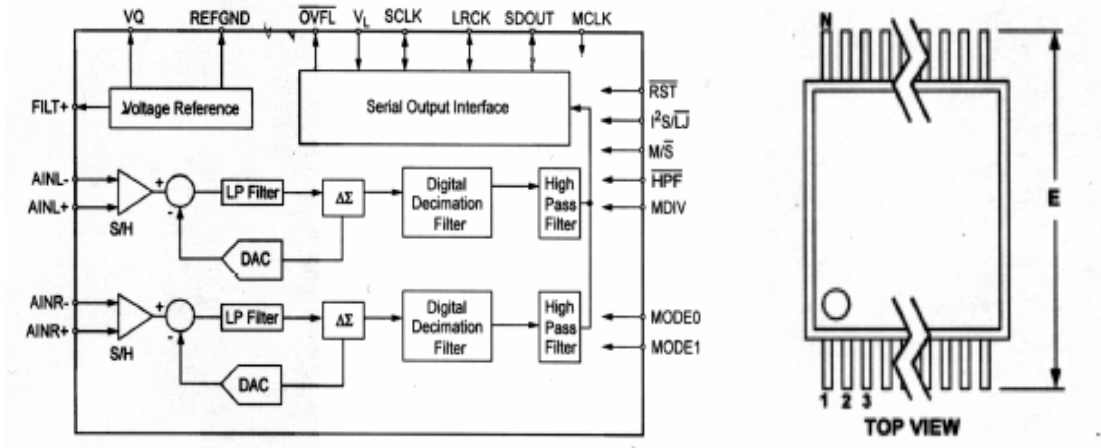

RST	1	24	FILT+
M/S	2	23	REFGND
LRCK	3	22	VQ
SCLK	4	21	AINR+
MCLK	5	20	AINR-
VD	6	19	VA
GND	7	18	GND
VL	8	17	AINL-
SDOUT	9	16	AINL+
MDIV	10	15	OVFL
HPF	11	14	M1
I <sup>2</sup> S/LJ	12	13	M0

CS49400  
DSP PART IC11

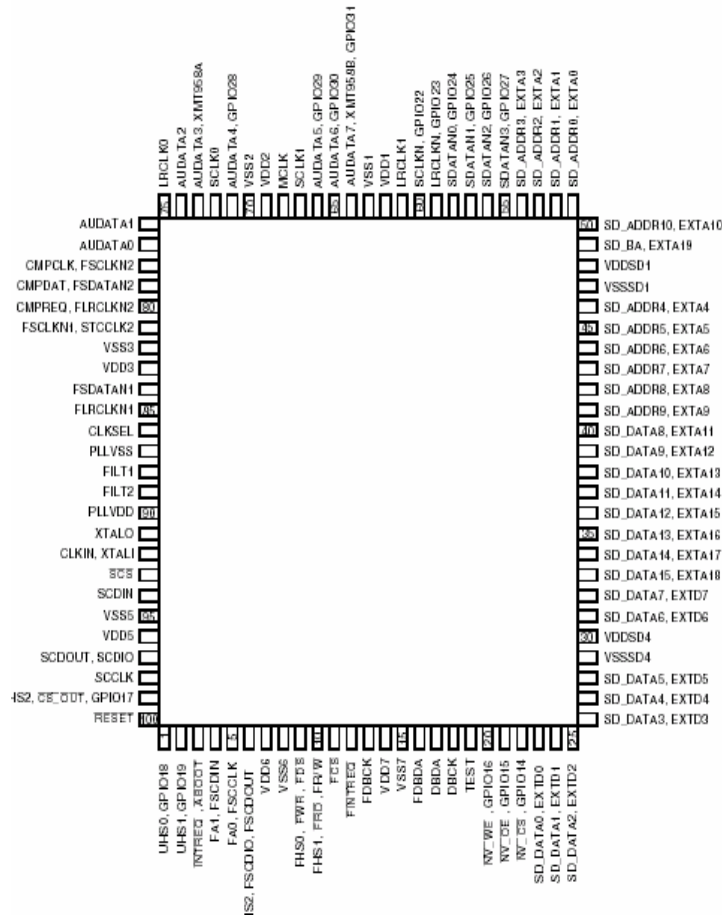

VPC3230D IC VIDEO DECODER  
 FAROUDJA PART IC10

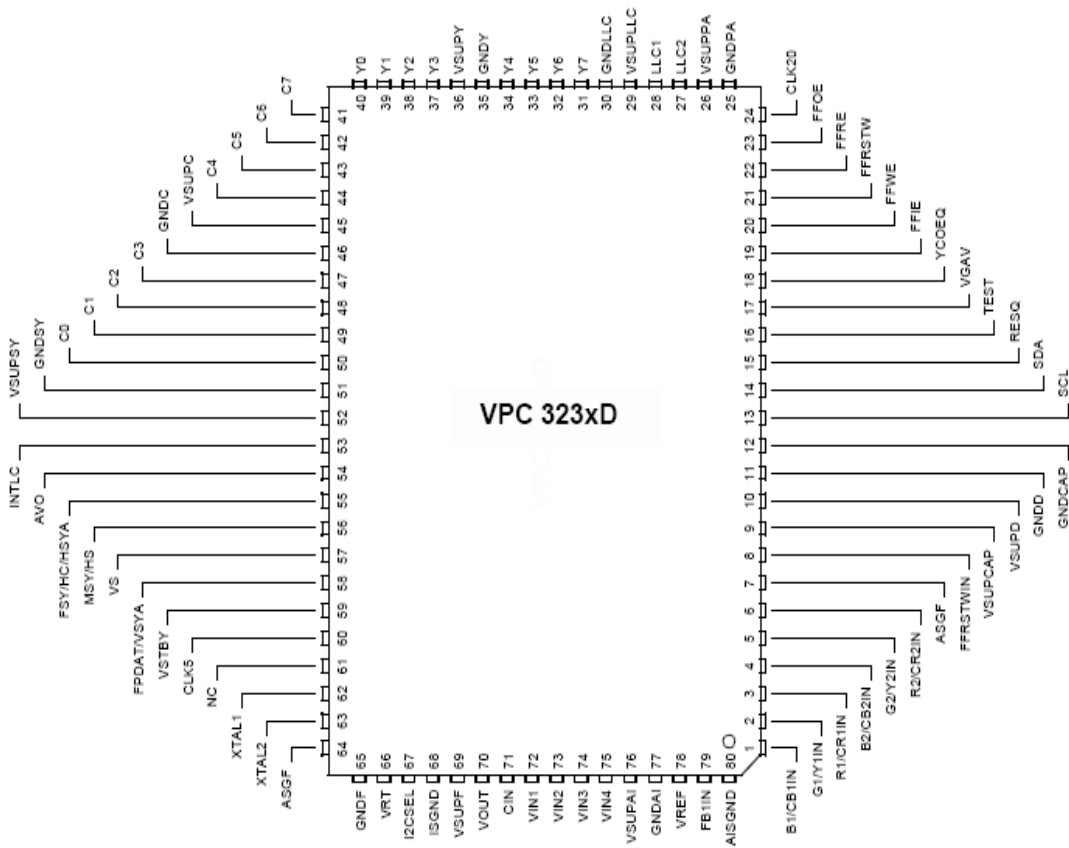
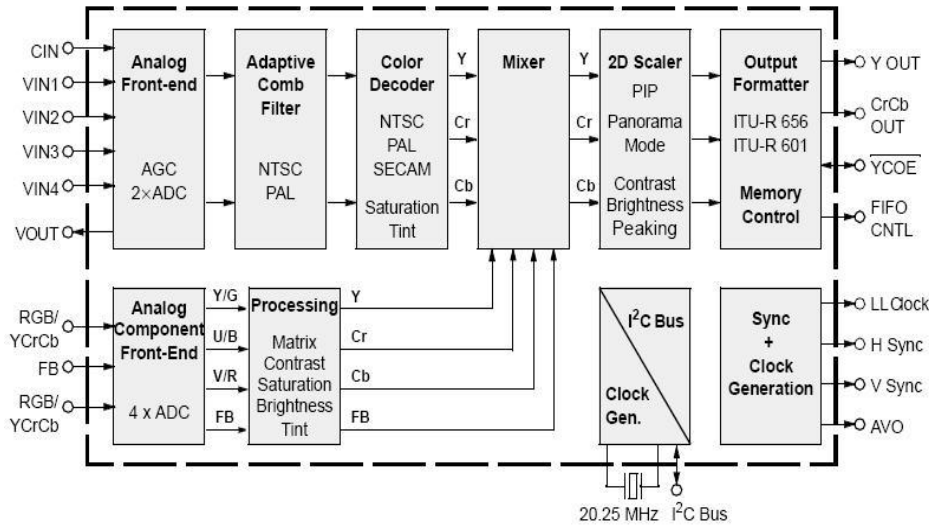

MM1623 VIDEO DRIVER  
PAROUDJA PART IC14

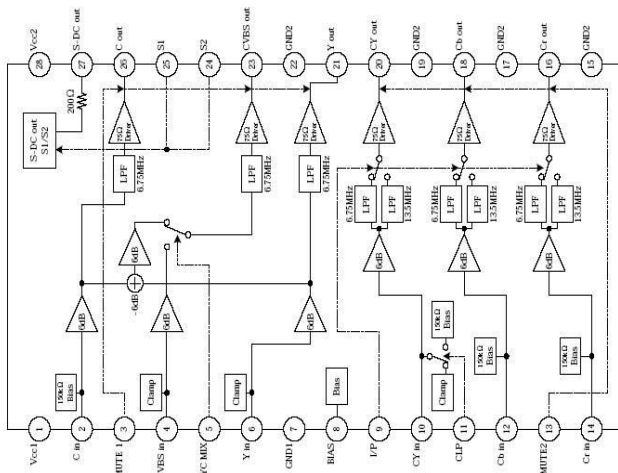

MM1623

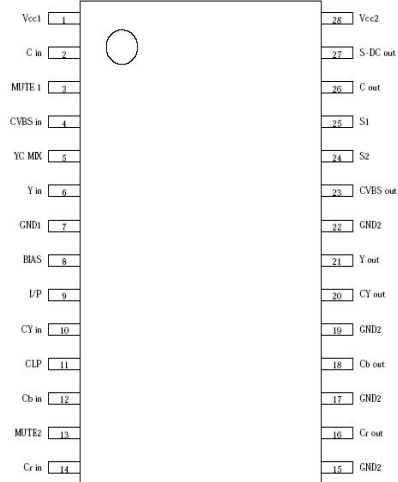
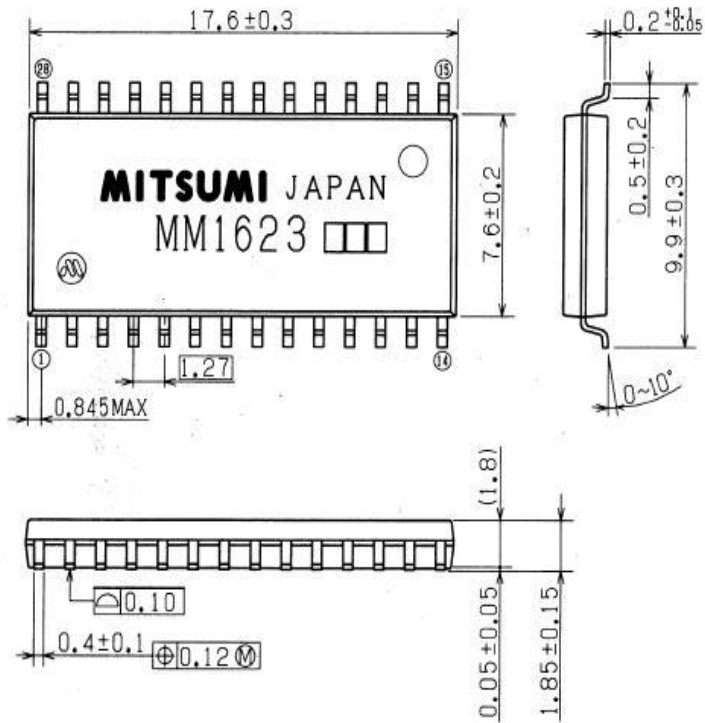

K4S643232F- TC60/TC70 (64M SDRAM)  
 FAROUDJA PART IC12

VDD	1	86	VSS
DQ0	2	85	DQ15
VDDQ	3	84	VSSQ
DQ1	4	83	DQ14
DQ2	5	82	DQ13
VSSQ	6	81	VDDQ
DQ3	7	80	DQ12
DQ4	8	79	DQ11
VDDQ	9	78	VSSQ
DQ5	10	77	DQ10
DQ6	11	76	DQ9
VSSQ	12	75	VDDQ
DQ7	13	74	DQ8
N.C	14	73	N.C
VDD	15	72	VSS
DQM0	16	71	DQM1
WE	17	70	N.C
CAS	18	69	N.C
RAS	19	68	CLK
CS	20	67	CKE
N.C	21	66	A9
BA0	22	65	A8
BA1	23	64	A7
A10/AP	24	63	A6
A0	25	62	A5
A1	26	61	A4
A2	27	60	A3
DQM2	28	59	DQM3
VDD	29	58	VSS
N.C	30	57	N.C
DQ16	31	56	DQ31
VSSQ	32	55	VDDQ
DQ17	33	54	DQ30
DQ18	34	53	DQ29
VDDQ	35	52	VSSQ
DQ19	36	51	DQ28
DQ20	37	50	DQ27
VSSQ	38	49	VDDQ
DQ21	39	48	DQ26
DQ22	40	47	DQ25
VDDQ	41	46	VSSQ
DQ23	42	45	DQ24
VDD	43	44	VSS

FUNCTIONAL BLOCK DIAGRAM

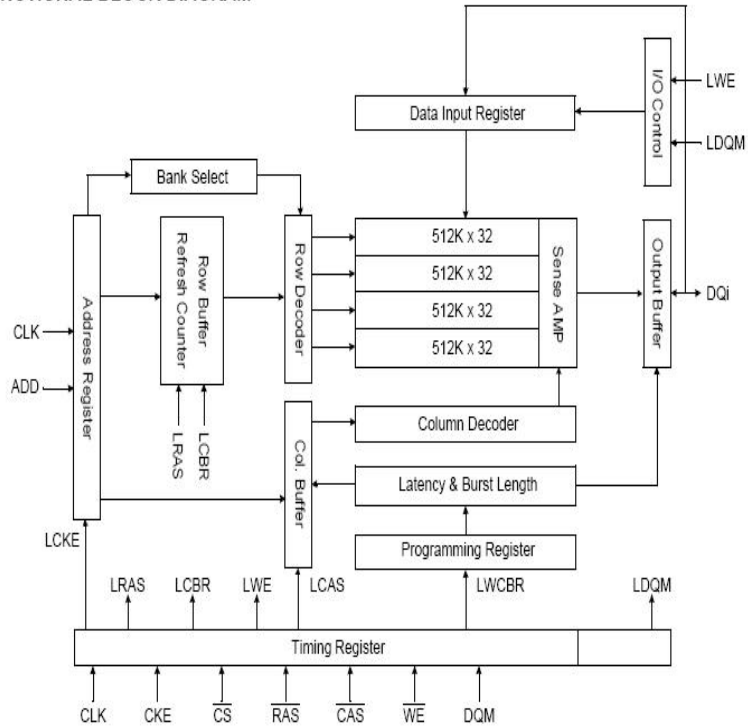

86Pin TSOP (II)  
 (400mil x 875mil)  
 (0.5 mm Pin pitch)

KRA107M  
DTA114YS  
VIDEO PA Q201,Q201

EQUIVALENT CIRCUIT

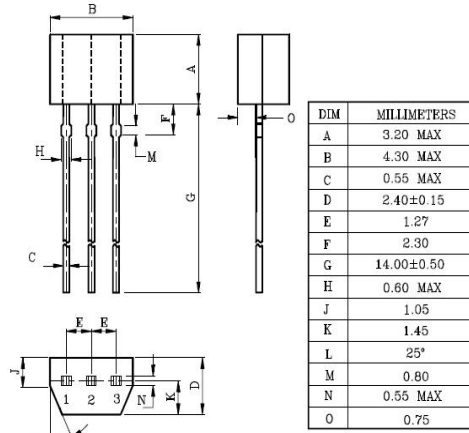
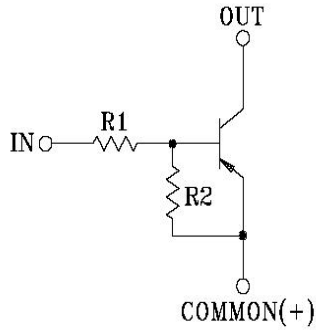

DIM	MILLIMETERS
A	3.20 MAX
B	4.30 MAX
C	0.55 MAX
D	2.40±0.15
E	1.27
F	2.30
G	14.00±0.50
H	0.60 MAX
J	1.05
K	1.45
L	25°
M	0.80
N	0.55 MAX
O	0.75

- 1. EMITTER
- 2. COLLECTOR
- 3. BASE

KRC107M  
DTC114YS  
3CH AMP Q901  
4CH AMP Q802

EQUIVALENT CIRCUIT

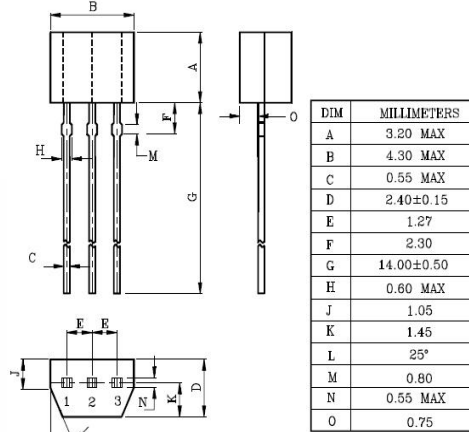
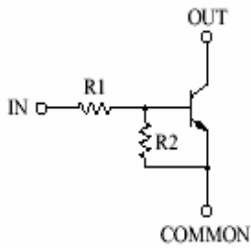

DIM	MILLIMETERS
A	3.20 MAX
B	4.30 MAX
C	0.55 MAX
D	2.40±0.15
E	1.27
F	2.30
G	14.00±0.50
H	0.60 MAX
J	1.05
K	1.45
L	25°
M	0.80
N	0.55 MAX
O	0.75

- 1. EMITTER
- 2. COLLECTOR
- 3. BASE

2SA1145Y  
MAIN PART Q5

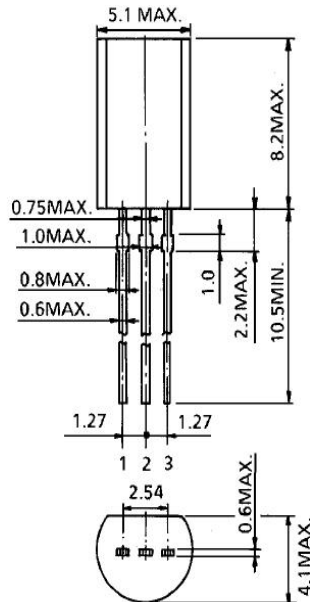
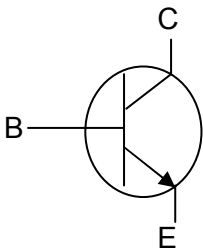

- 1. EMITTER
- 2. COLLECTOR
- 3. BASE

2SA933  
 FAROUDJ Q100,Q101,Q104  
 MAIN PAR Q213,Q214  
 SUPPLY Q501

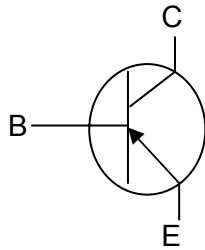

2SA933AS

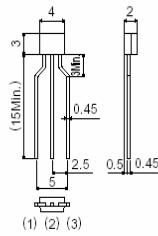

Taping specifications

ROHM : SPT  
 EIAJ : SC-72  
 (1) Emitter  
 (2) Collector  
 (3) Base

2SC1740S  
 3CHAMP Q926,Q927,Q928  
 MAIN Q211,Q7

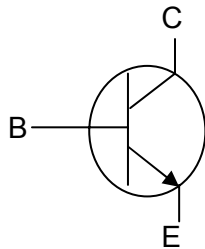

2SC1740S

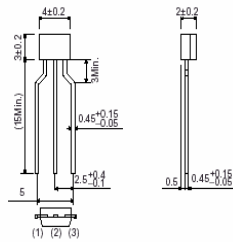

ROHM : SPT  
 EIAJ : SC-72  
 (1) Emitter  
 (2) Collector  
 (3) Base

KTA1024Y  
 3CHAMP Q901  
 4CHAMP Q801

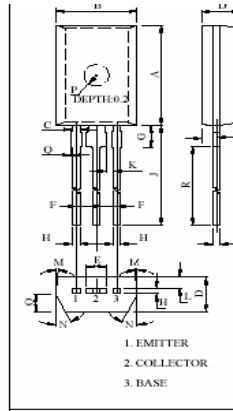
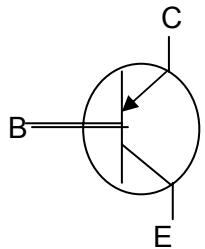

2SA1370  
 3CH AMP Q106,Q206,Q306  
 4CH AMP Q406,Q506,Q606,Q706

[2SA1370]

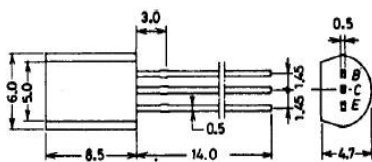

EIAJ : SC-51  
 SANYO : MP  
 B : Base  
 C : Collector  
 E : Emitter



KTA1266  
3CHAMP Q925

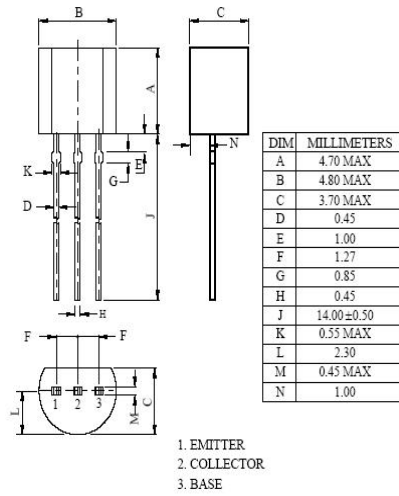

KTA1268  
3CH AMP Q107,Q207,Q307  
4CH AMP Q407,Q507,Q607,Q707

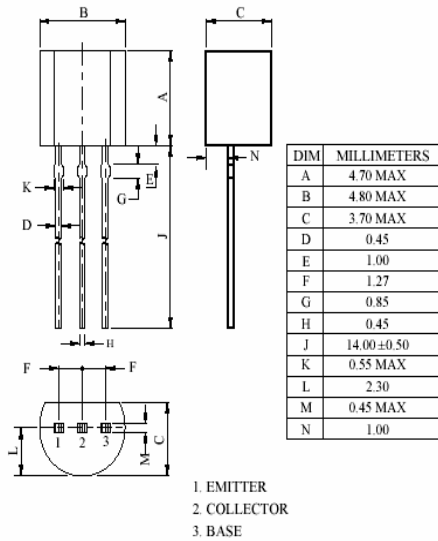

KTC3198  
3CH AMP Q105,Q123,Q205,Q223,Q305,Q323  
4CH AMP Q405,Q423,Q505,Q523,Q605,Q623,Q705,Q723  
MAIN Q6

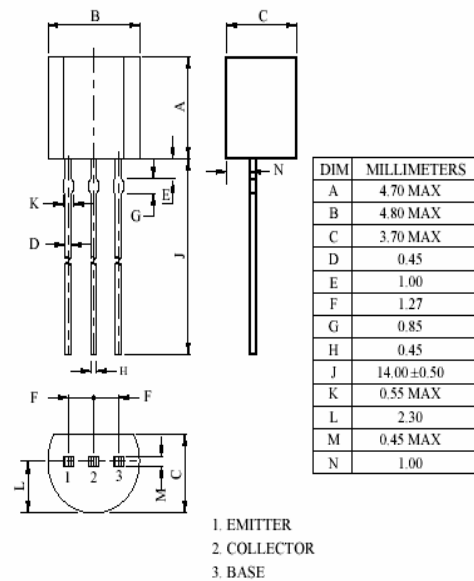

KTC3200

3CHAMP Q101,Q102,Q103,Q104,Q122,Q201~4,Q222,Q301,Q302,Q303,Q304,Q322

4CHAMP Q401~4,Q422,Q501~Q504,Q522,Q601~4,Q622,Q701~4,Q722

TO-92

- 1. EMITTER
- 2. COLLECTOR
- 3. BASE



KTD1302

MAIN  
PROCESSOR

Q241  
Q1,Q18,Q19,Q21

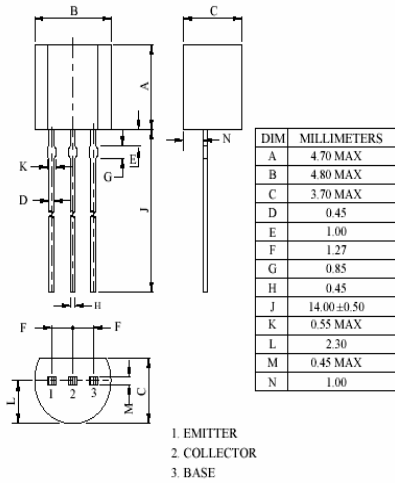

MPSA06

DSP  
PROCESSOR  
SUPPLY

Q611  
Q2, Q5  
Q452,Q453,Q454,Q455,Q456,Q460

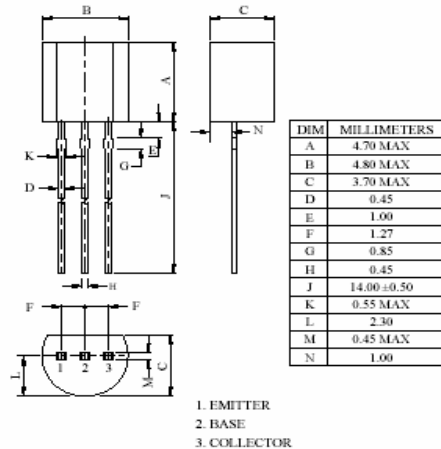
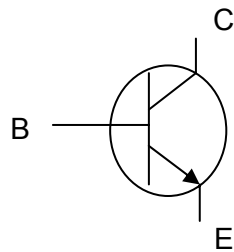

MPSA56  
PROCESSOR

Q4,Q6

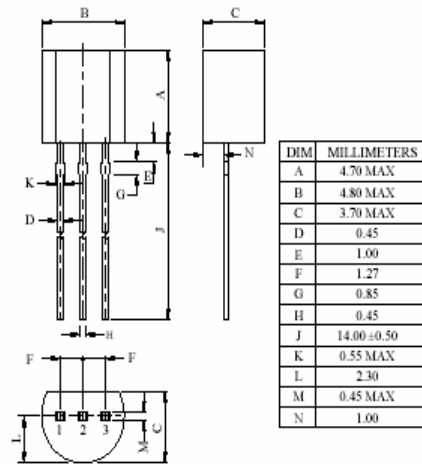
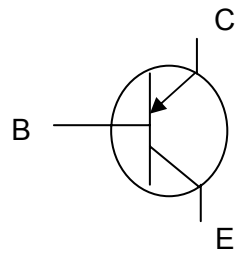

- 1. EMITTER
- 2. BASE
- 3. COLLECTOR

2SC3423

3CH AMP Q110,Q111,Q114,Q210,Q211,Q214,Q310,Q311,Q314

4CH AMP Q410,Q421,Q414,Q510,Q511,Q514,Q610,Q611,Q614,Q710,Q711,Q714

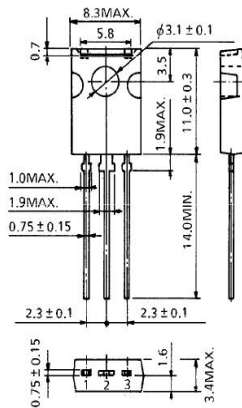

- 1. EMITTER
- 2. COLLECTOR
- 3. BASE

2SC4137

3CH Q112,Q212,Q312

4CH Q412,Q512,Q612,Q712

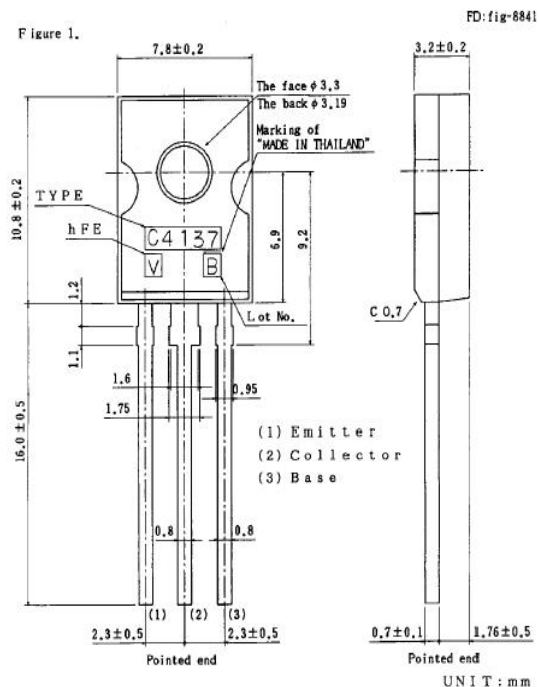

2SA1360

3CH AMP Q108,Q109,Q208,Q209,Q308,Q309,Q116,Q216,Q316

4CH AMP Q408,Q409,Q508,Q509,Q608,Q609,Q708,Q709,Q416,Q516,Q616,Q716

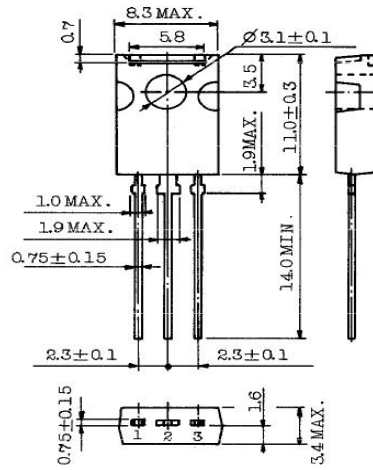

1. EMITTER
2. COLLECTOR
3. BASE

2SC4883

3CH AMP Q117,Q217,Q317

4CH AMP Q417,Q517,Q617,Q717

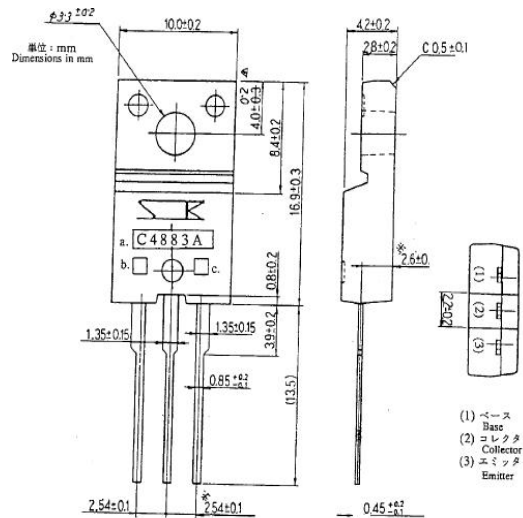

- (1) ベース  
Base
- (2) コレクタ  
Collector
- (3) エミッタ  
Emitter

S2SA1859

3CH AMP Q115,Q215,Q315

4CH AMP Q415,Q515,Q615,Q715

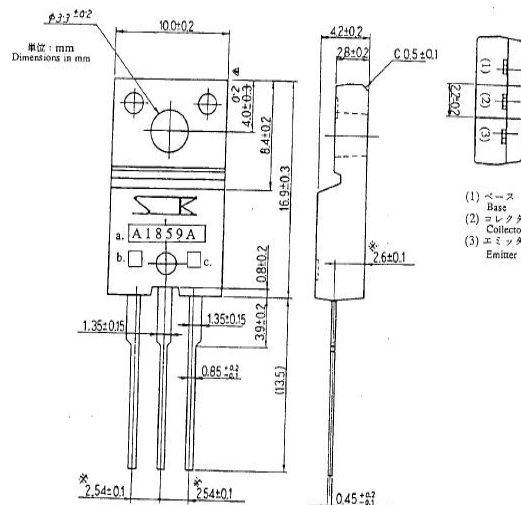

- (1) ベース  
Base
- (2) コレクタ  
Collector
- (3) エミッタ  
Emitter

2SA1943

3CH AMP Q120,Q121,Q120,Q221,Q320,Q321

4CCH AMI Q420,Q421,Q520,Q521,Q620,Q621,Q720,Q721

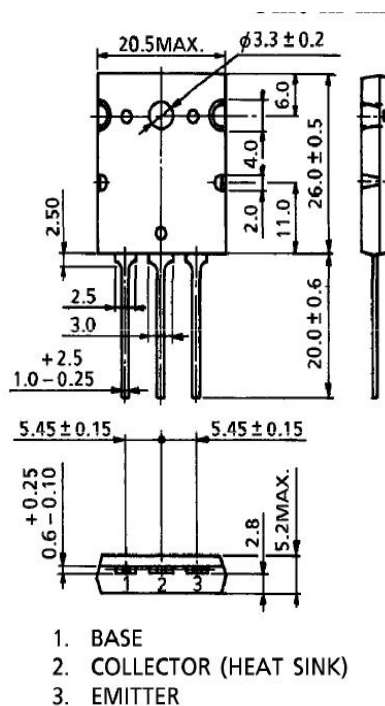

2SC5200

3CH AMP Q118,Q119,Q218,Q219,Q318,Q319,

4CH AMP Q418,Q419,Q518,Q519,Q618,Q619,Q718,Q7198

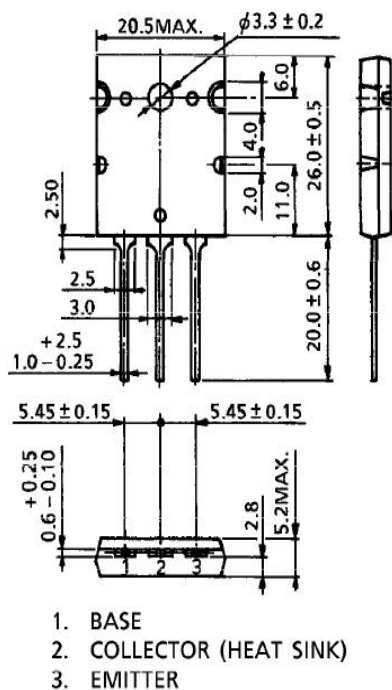

SMD  
 DTA114YKAP  
 DSP Q402,Q403  
 MAIN Q4,Q215,Q617,Q717  
 PROCESSOR Q3,Q13,Q14,Q17,Q20,Q23,Q25,Q32,Q34,Q35,Q37,Q41,Q43,Q50,Q52  
 VIDEO Q603,Q604

EQUIVALENT CIRCUIT

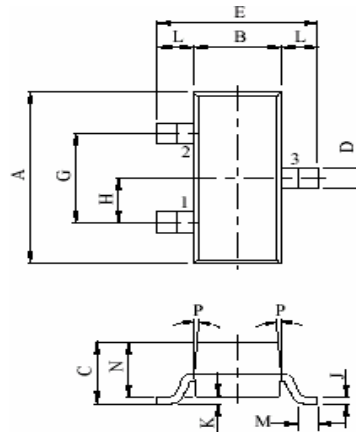
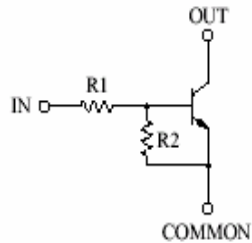

- 1. COMMON (EMITTER)
- 2. IN (BASE)
- 3. OUT (COLLECTOR)

DTC114YKA  
 DSP Q600,Q601,Q604,Q605,Q606,Q607,Q608,Q609,Q612,Q613  
 FAROUDJ Q106,Q107  
 FRONT Q701,Q703,Q704,Q705  
 MAIN Q1,Q2,Q201,Q202,Q203,Q204,Q212  
 PROCESSOR Q54,Q22  
 VEDIO Q611,Q612,Q613

EQUIVALENT CIRCUIT

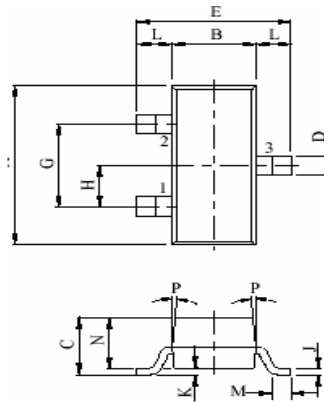
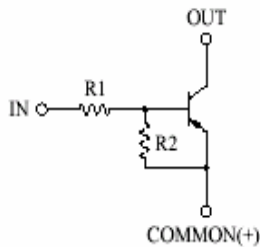

- 1. COMMON (EMITTER)
- 2. IN (BASE)
- 3. OUT (COLLECTOR)

KTD13(  
 DSP  
 FRONT Q702  
 PROCESSOR Q24,Q26,Q27~Q31,Q33,  
 Q36,Q38~40,Q42,Q44~46  
 Q7~12,Q15~16,Q51,Q53,Q58,Q59

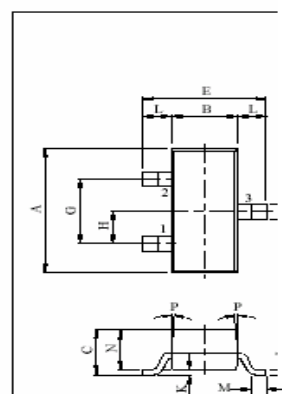
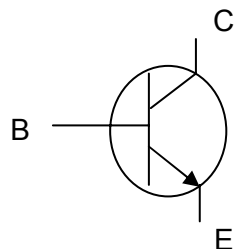

- 1. EMITTER
- 2. BASE

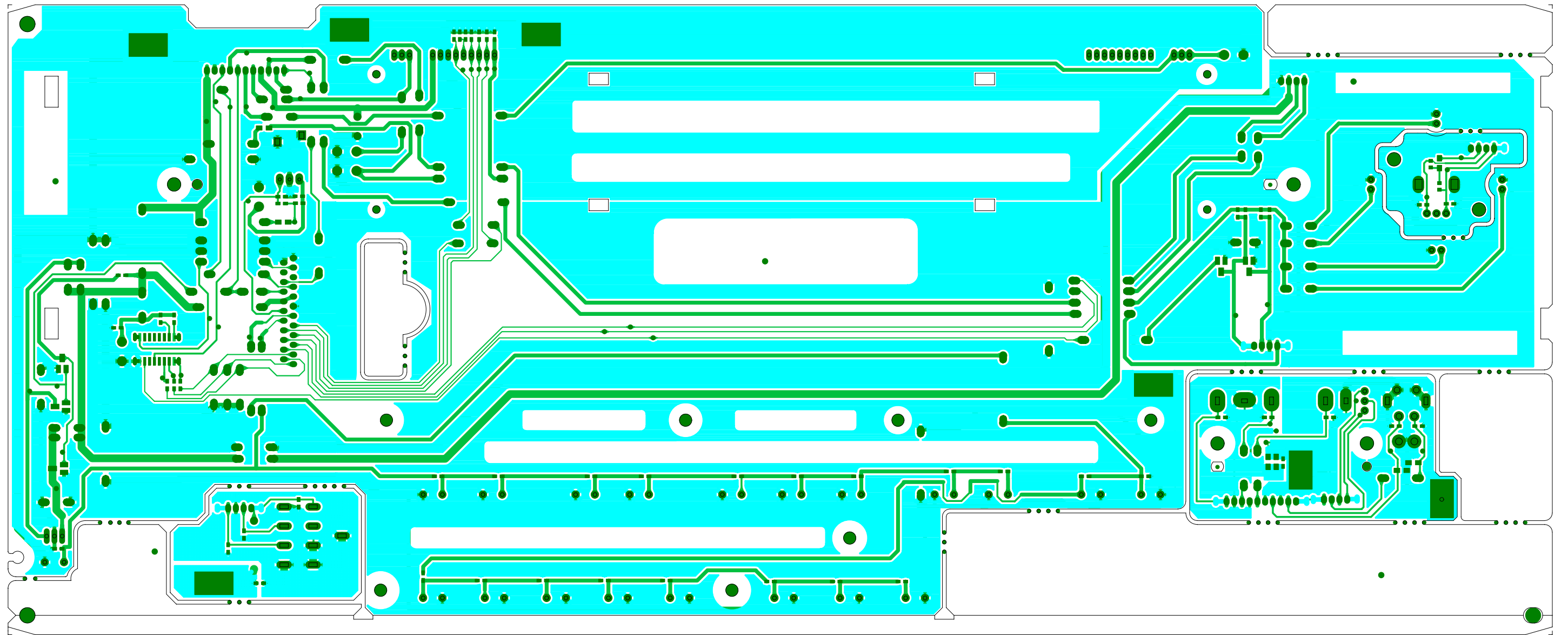

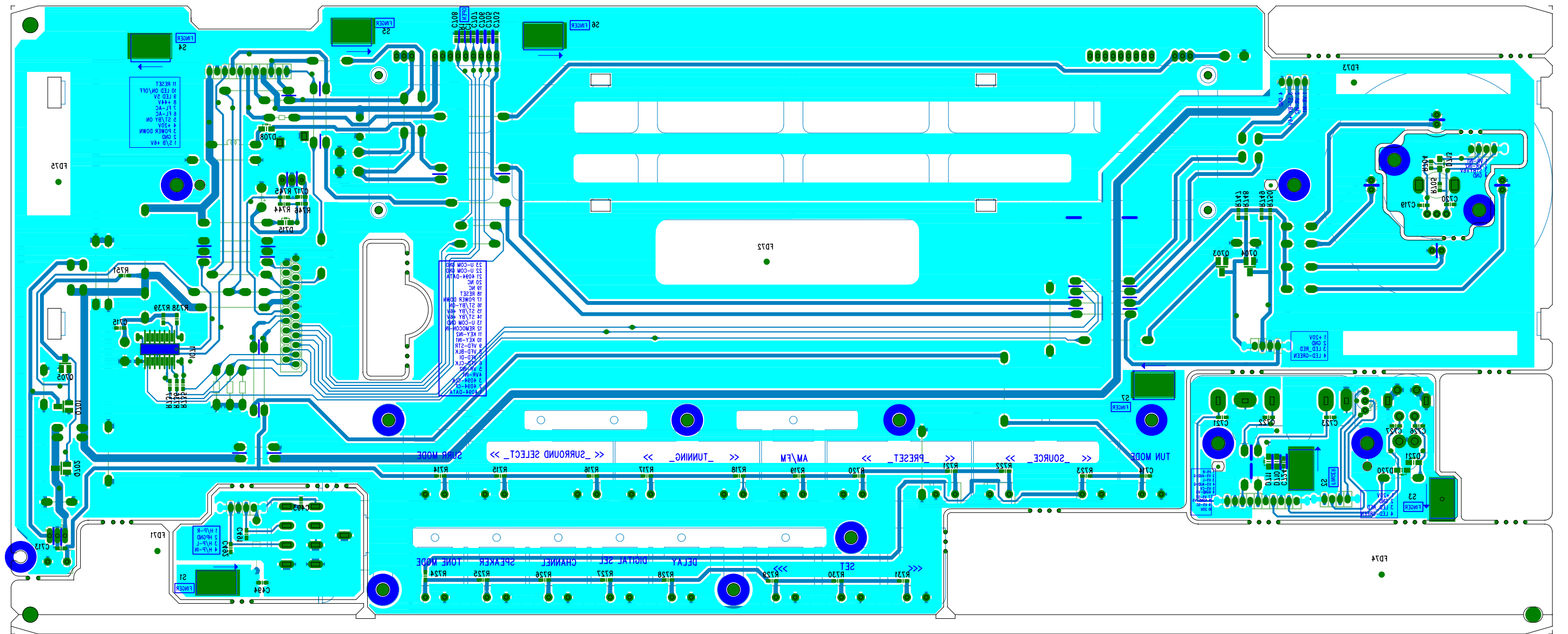



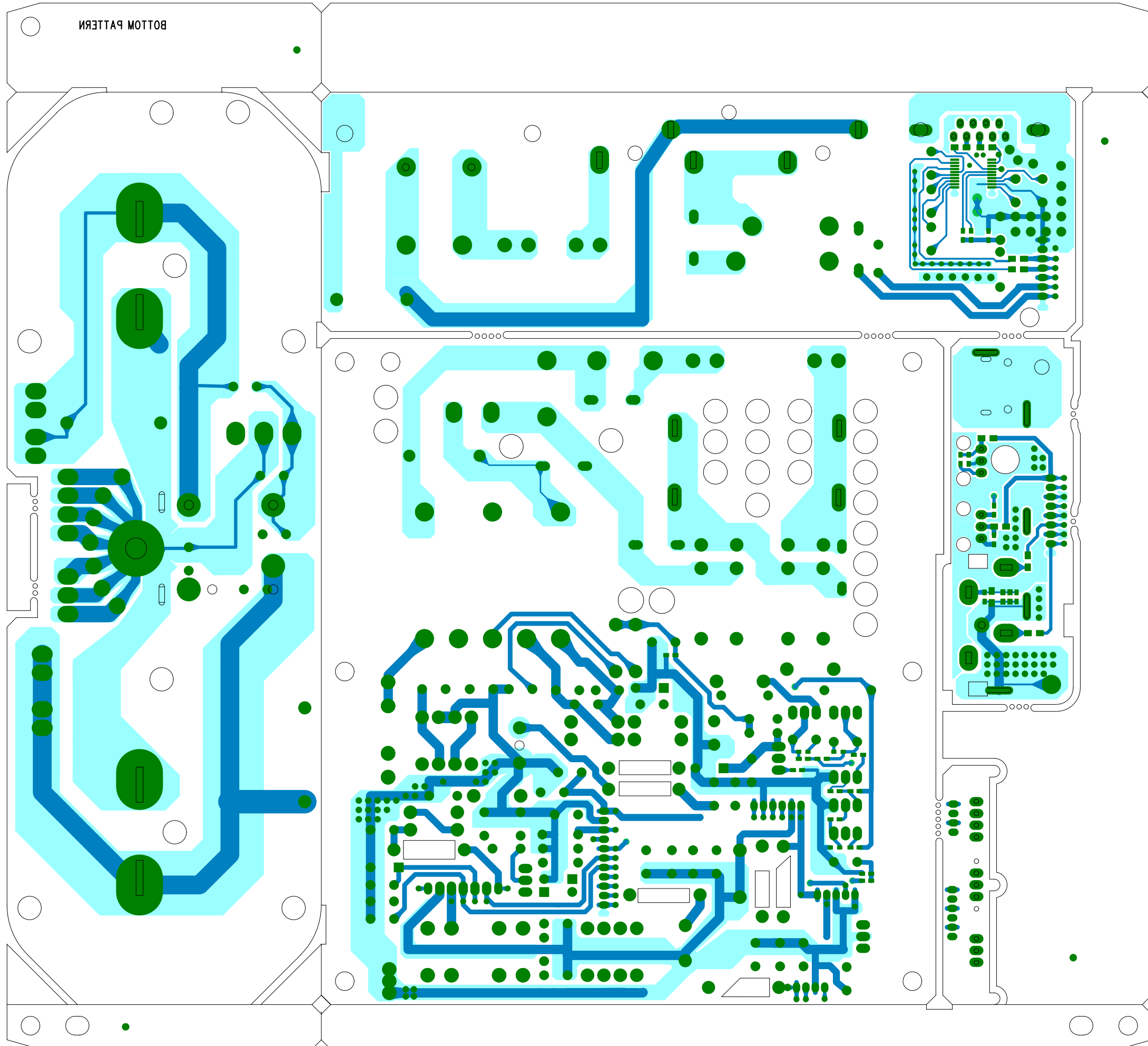

BOTTOM PATTERN



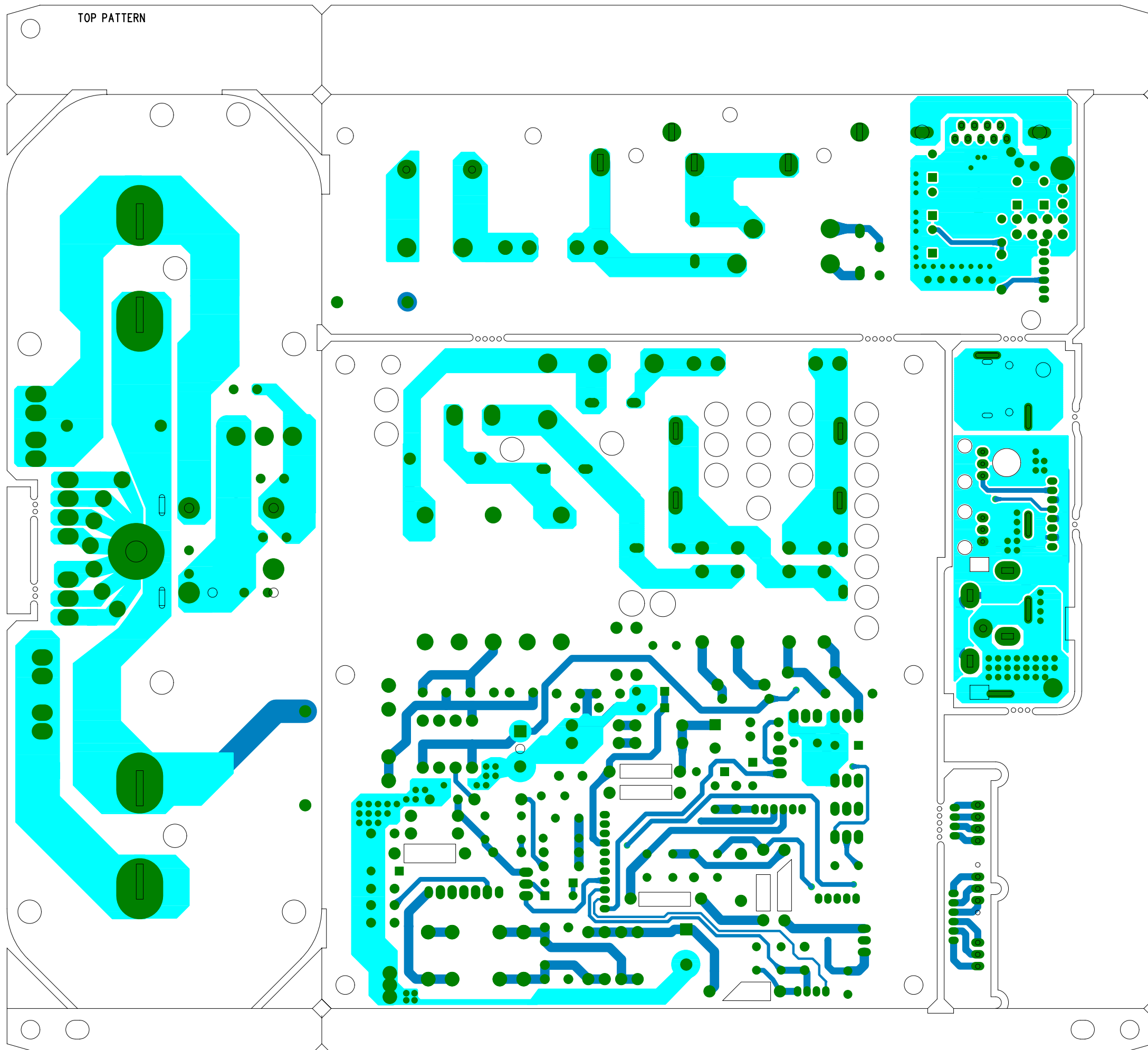

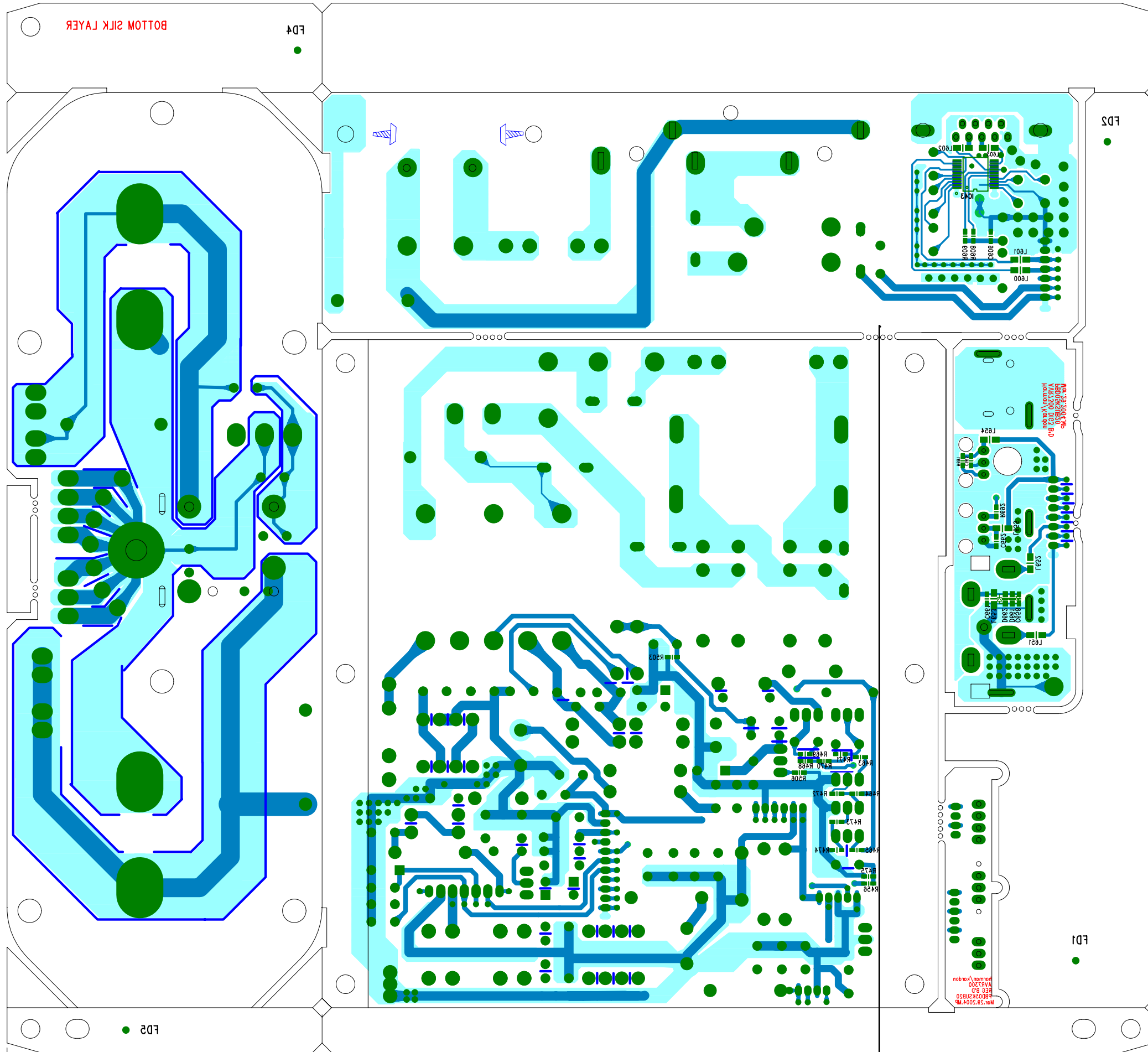

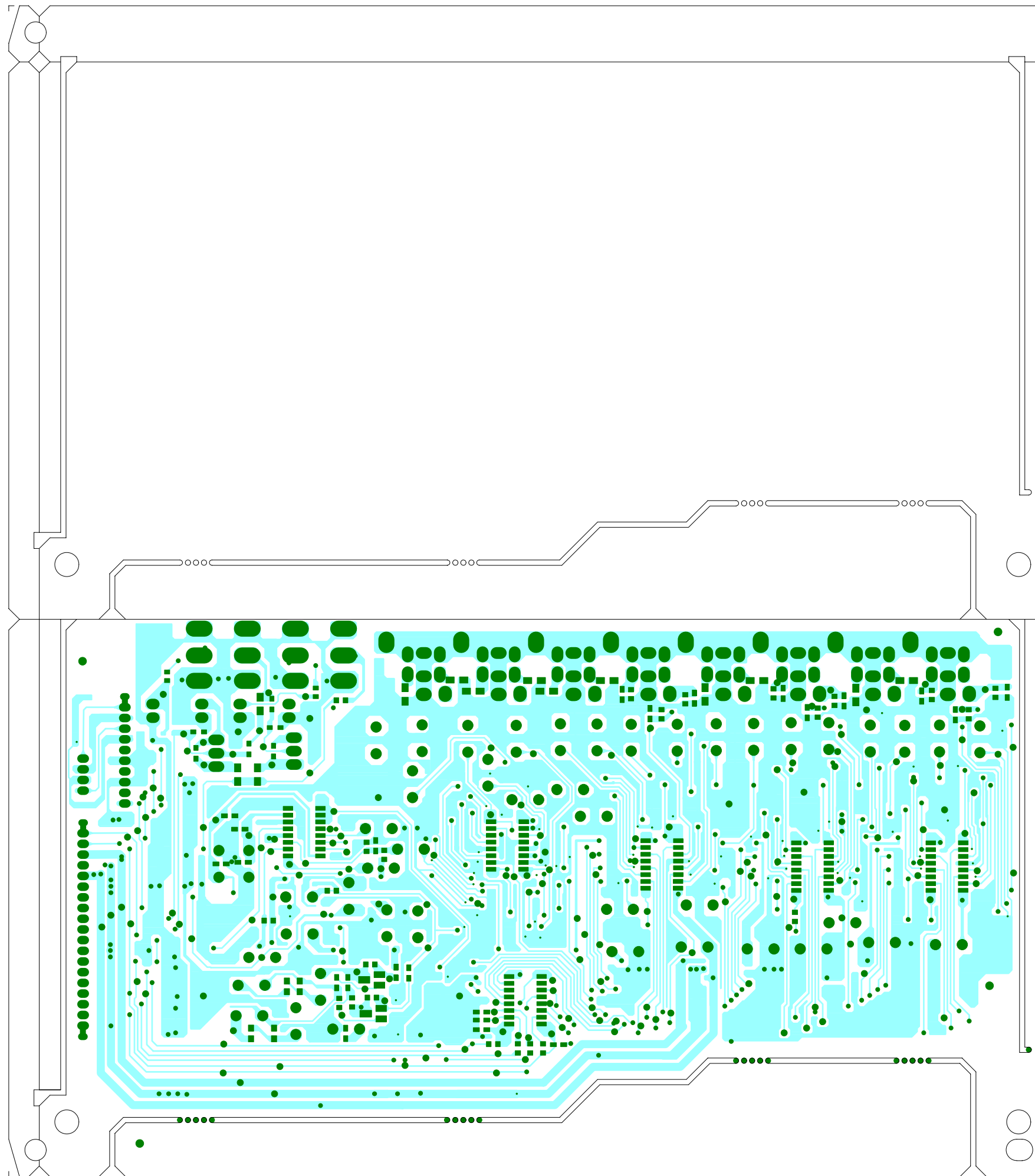





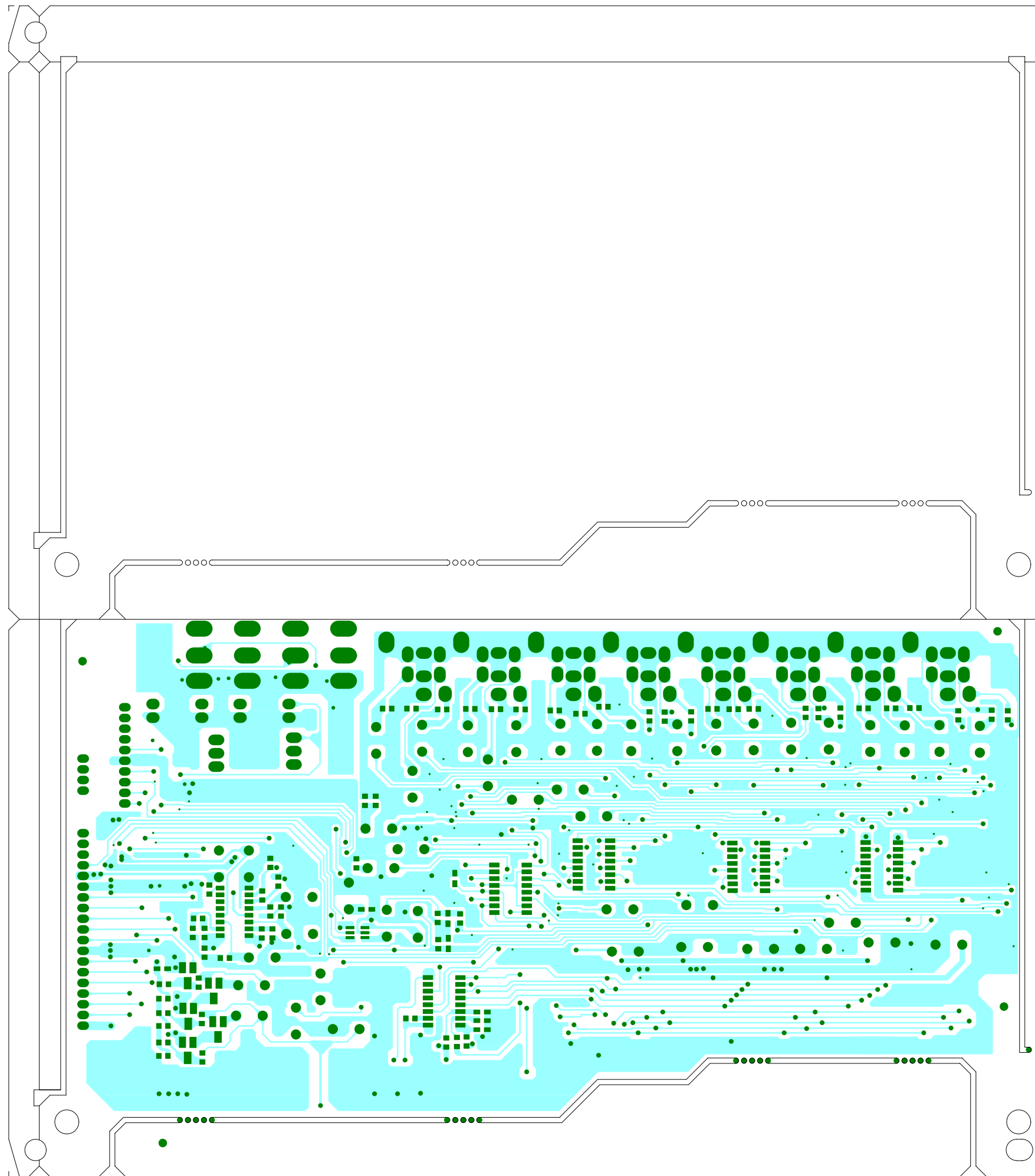

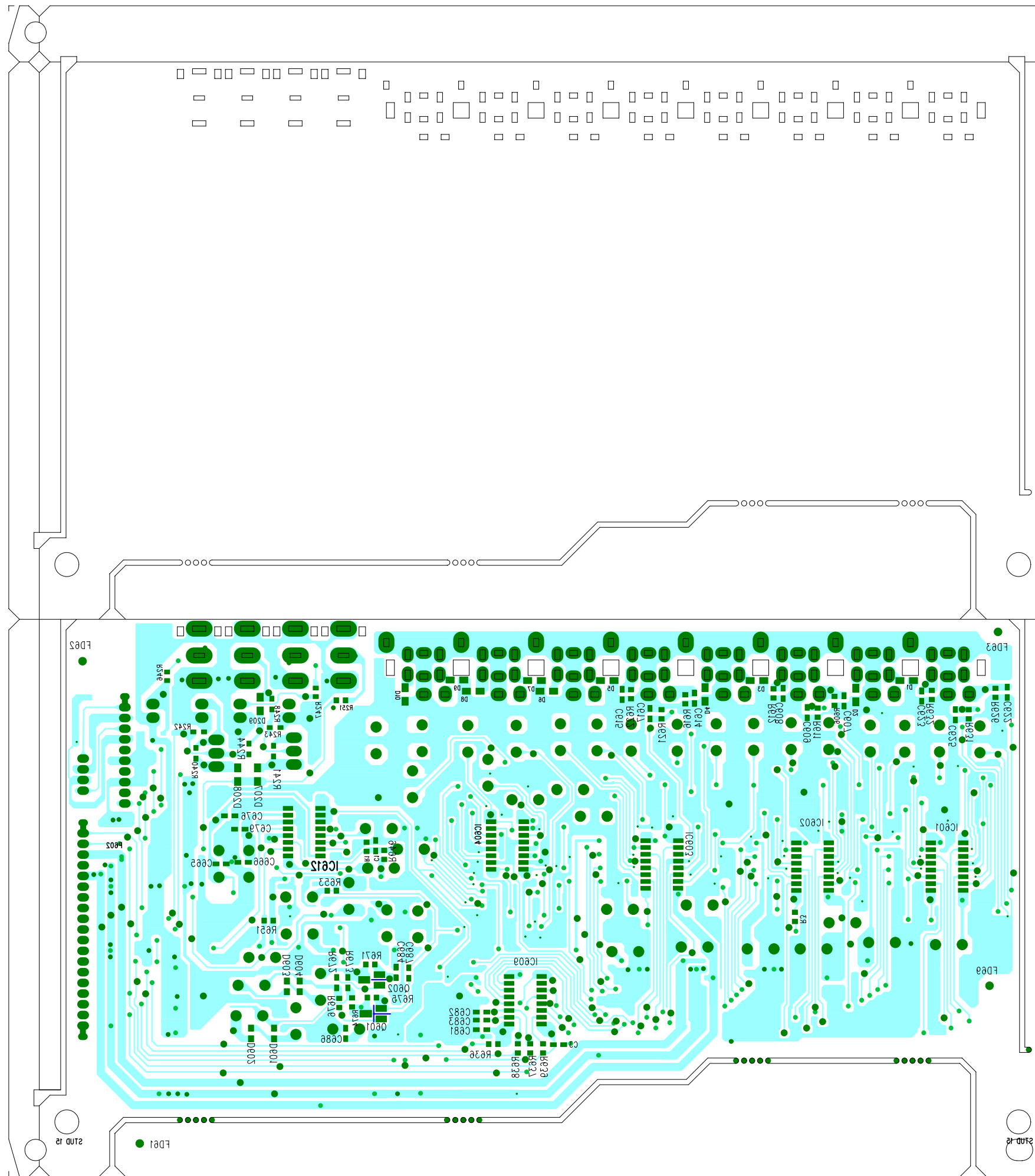



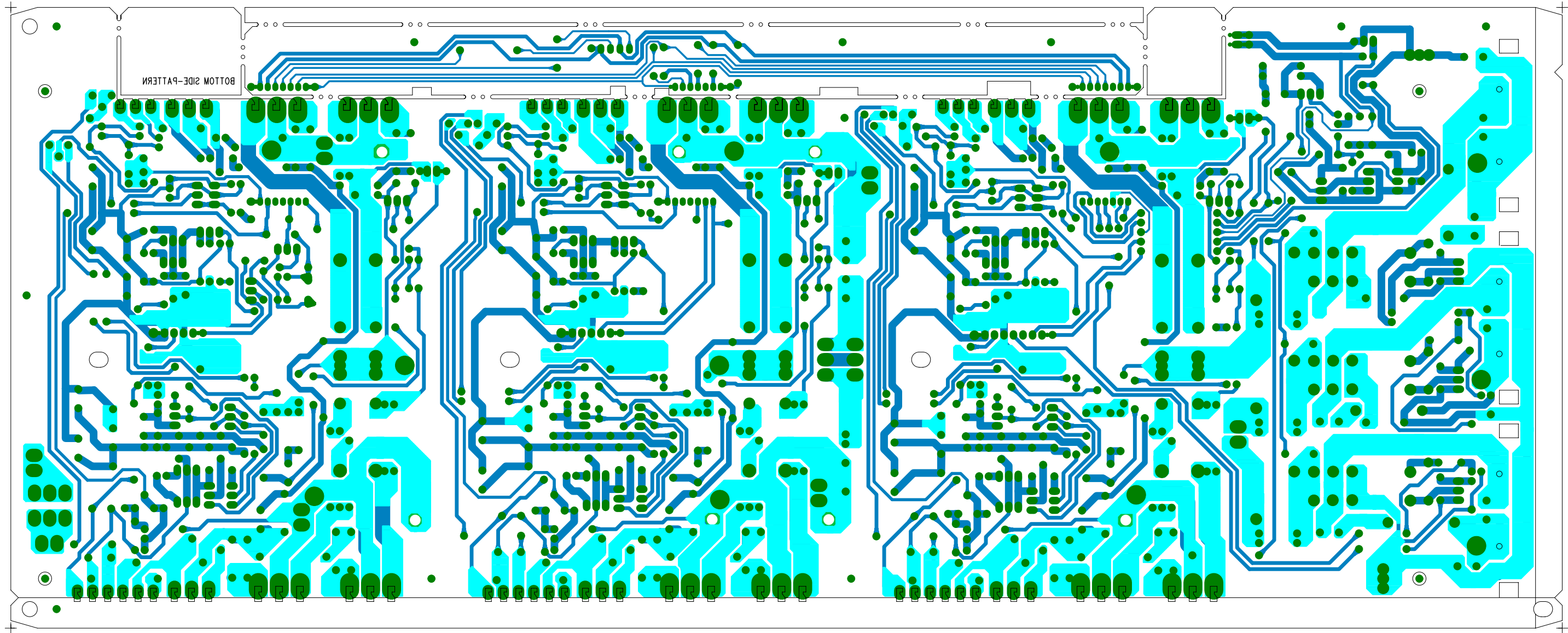

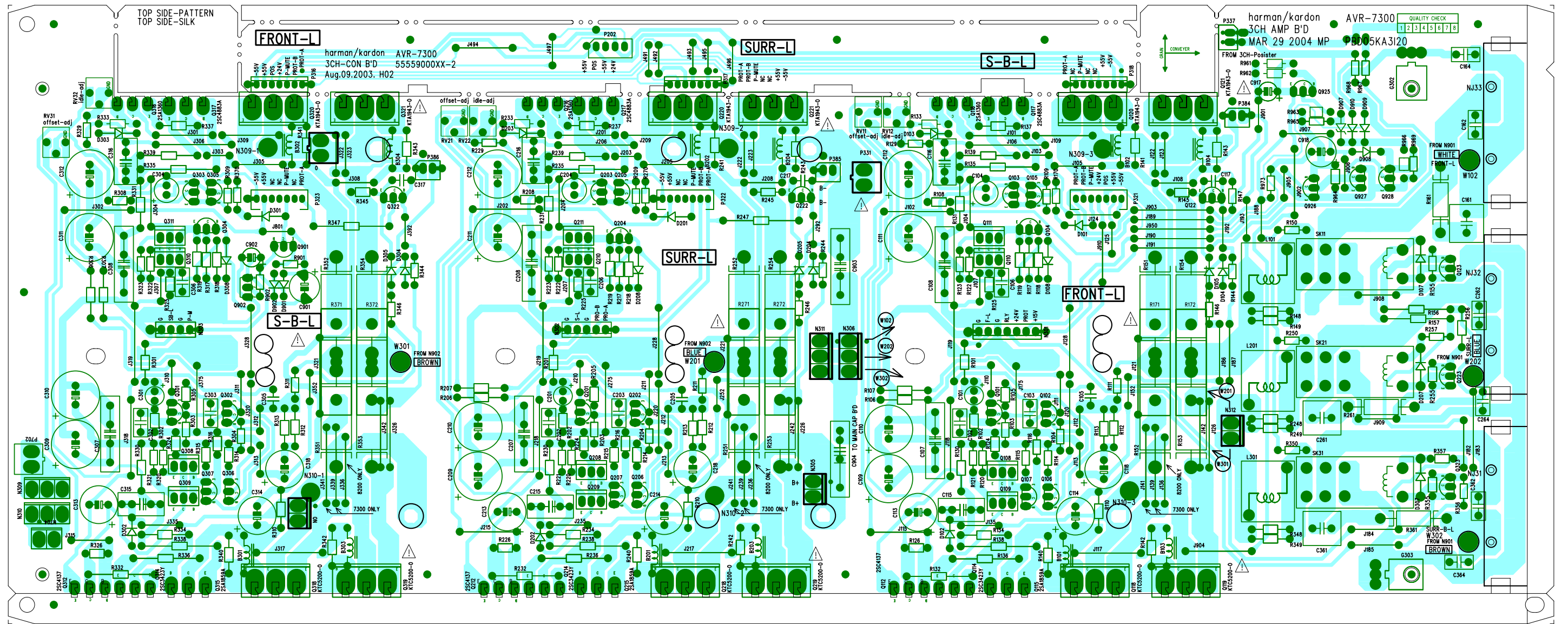

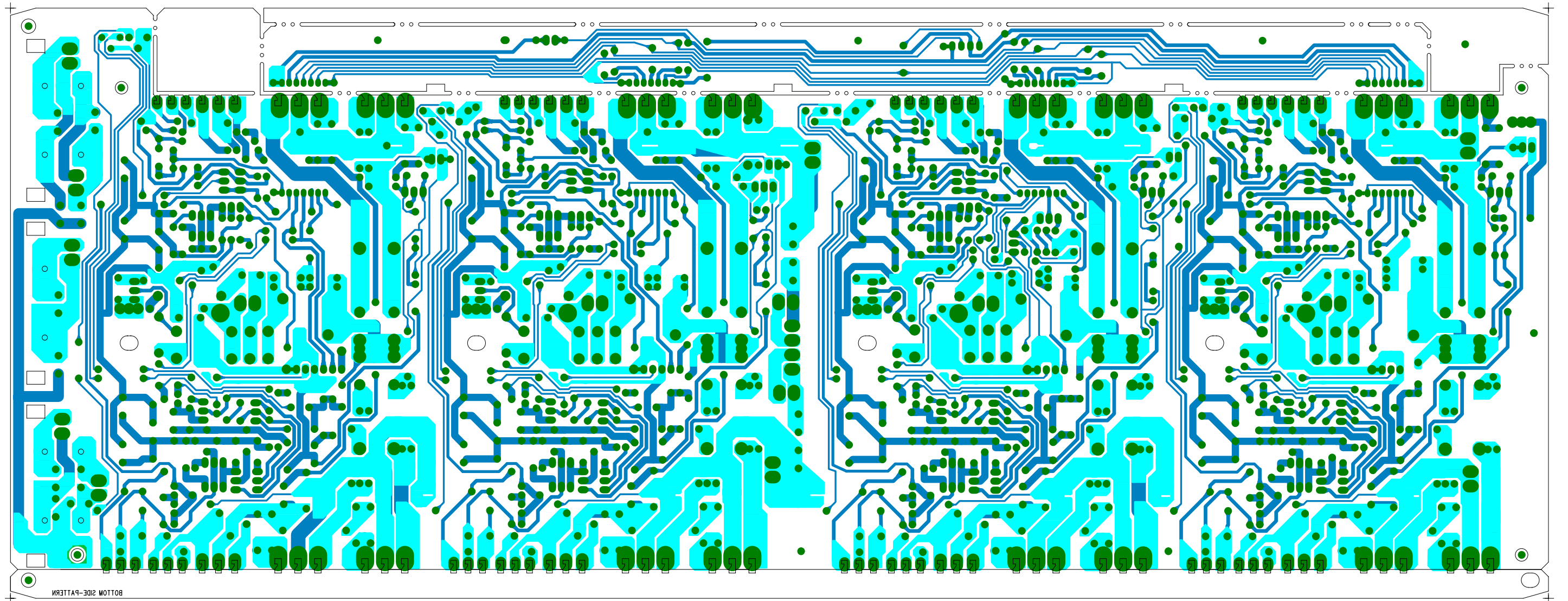



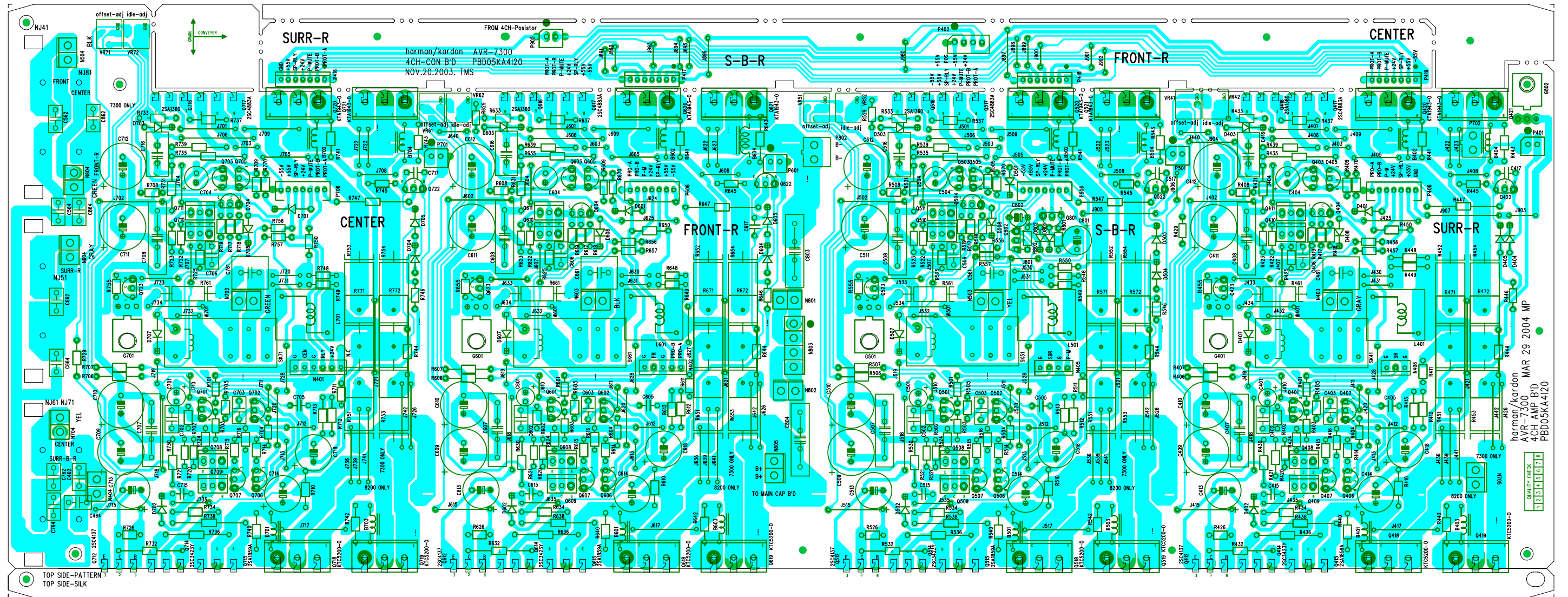

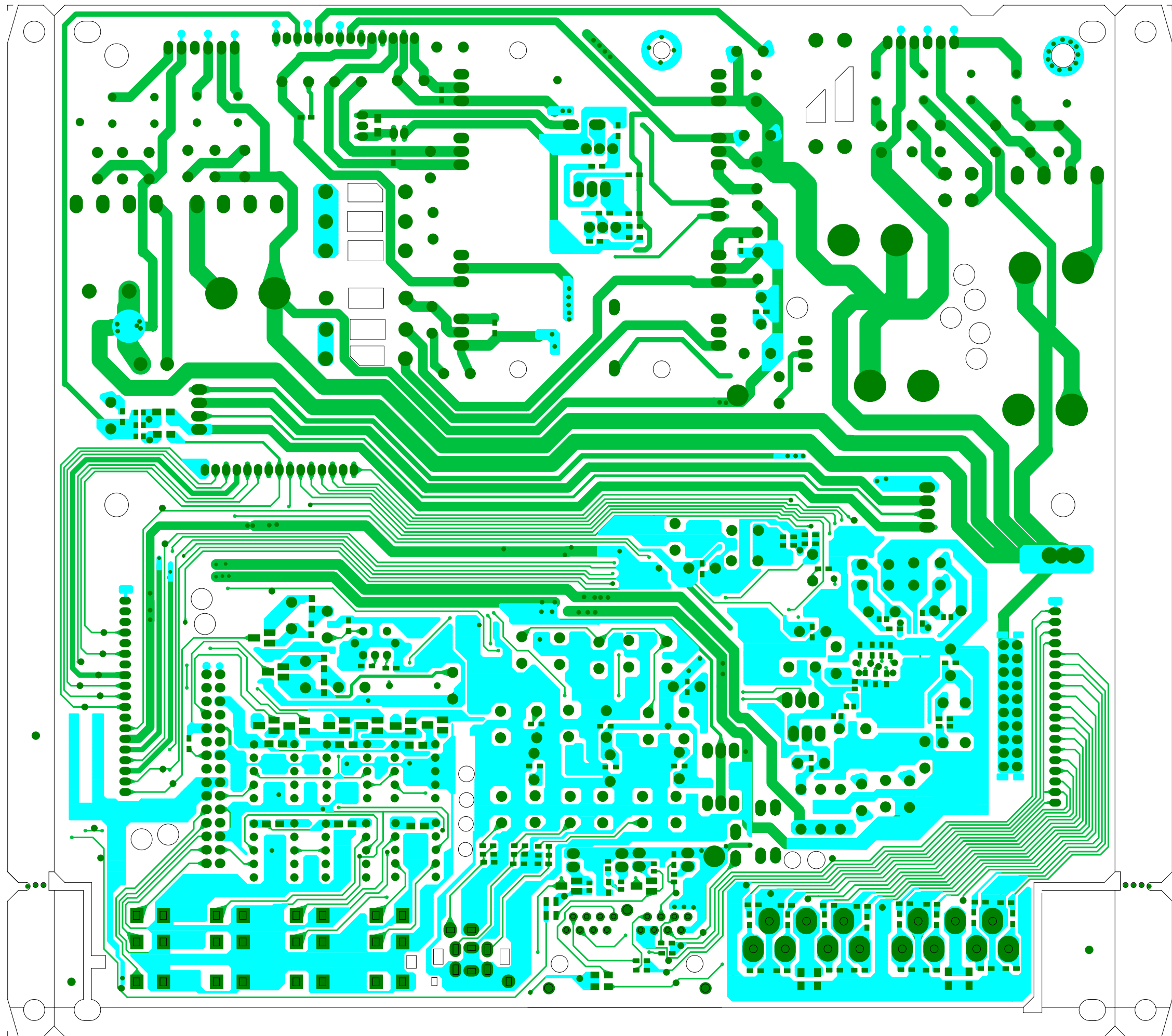

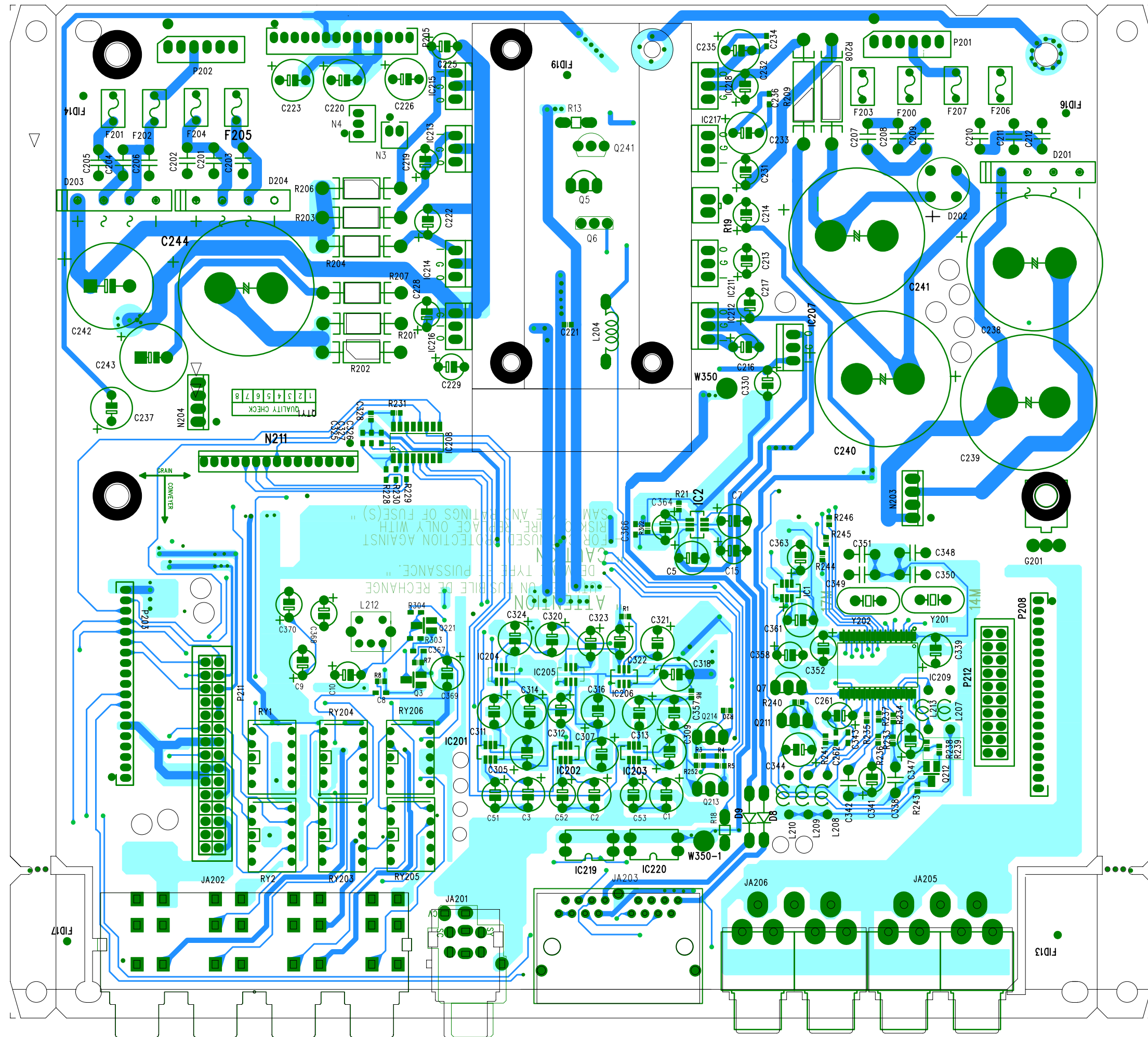



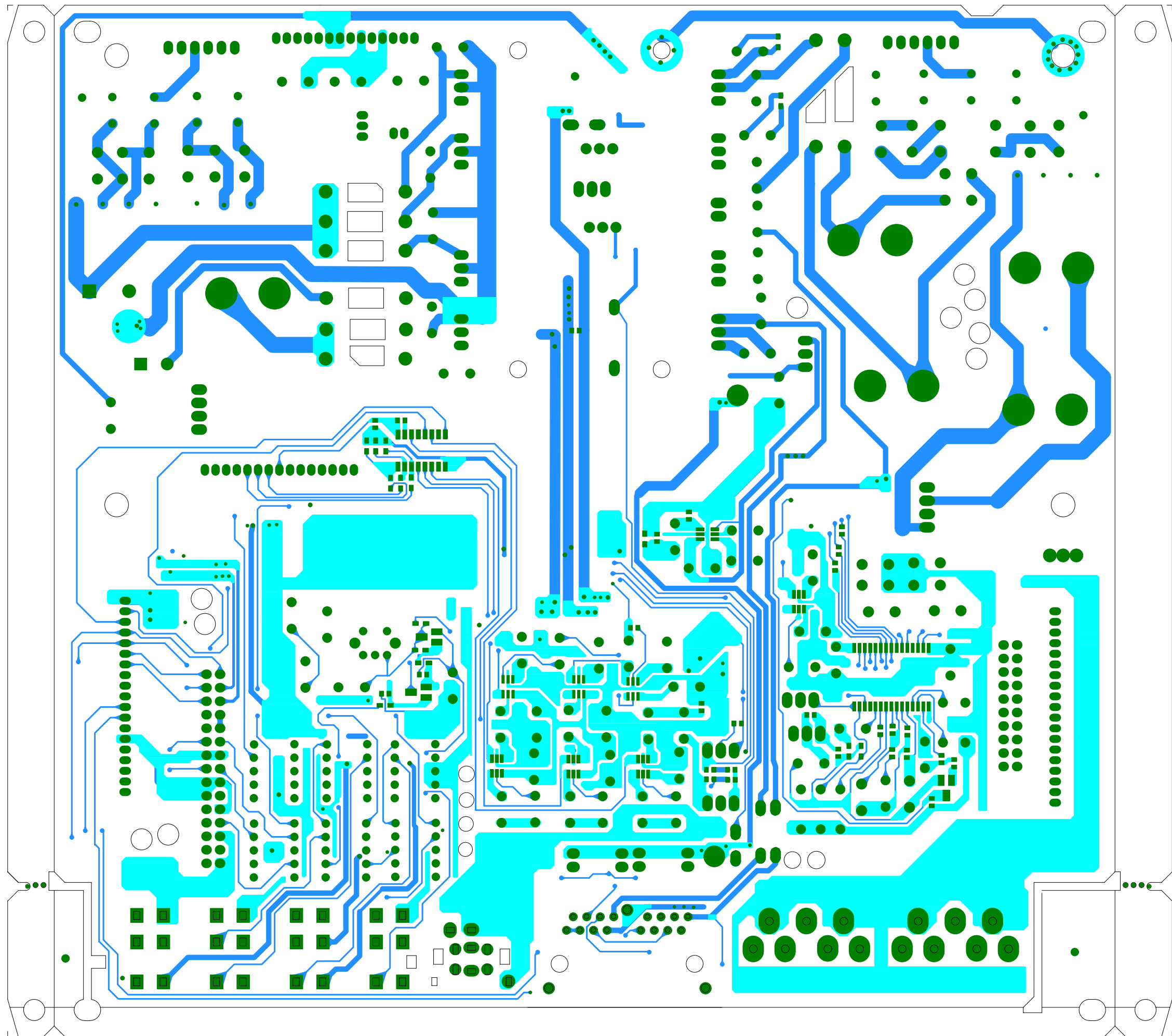

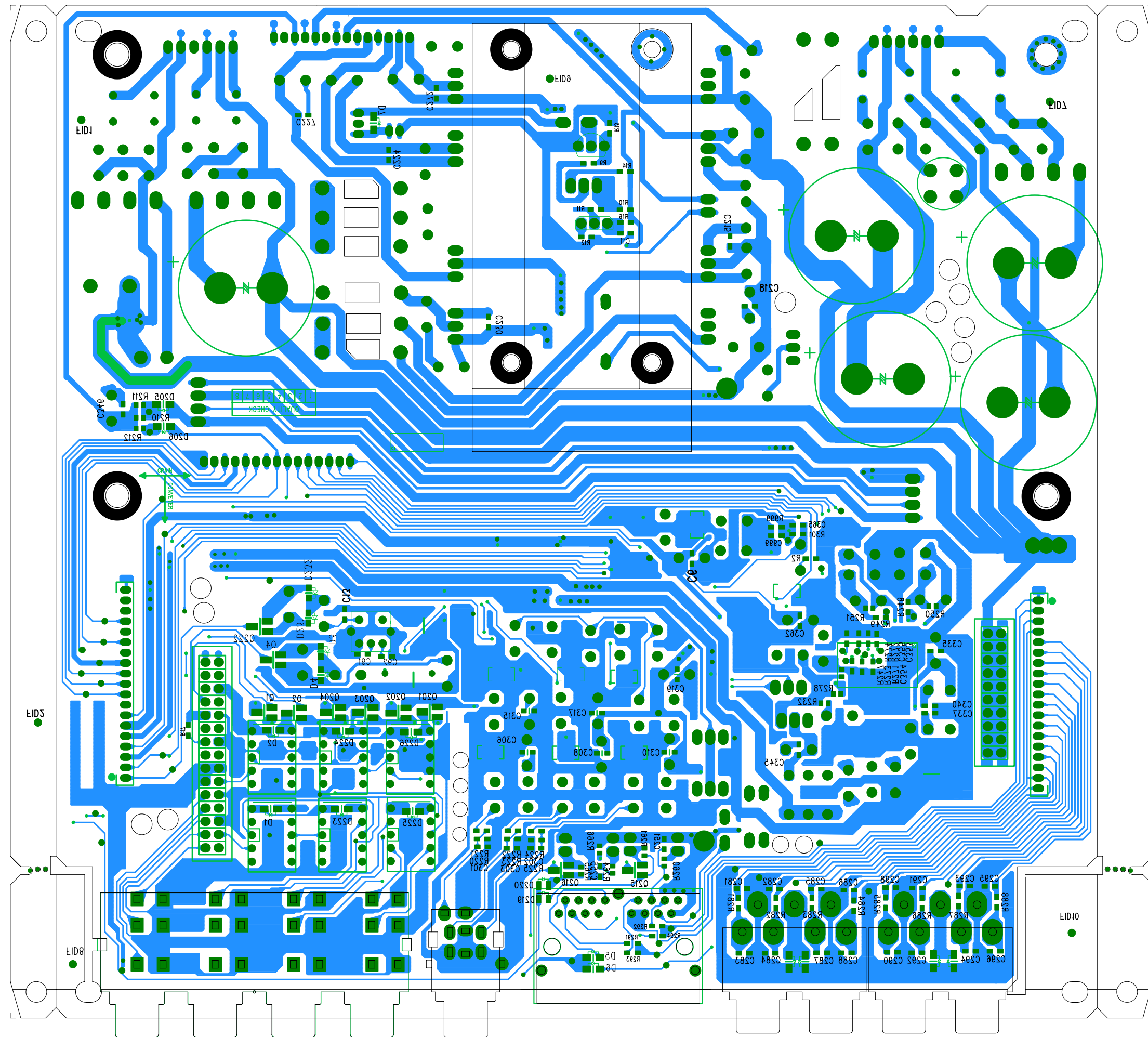



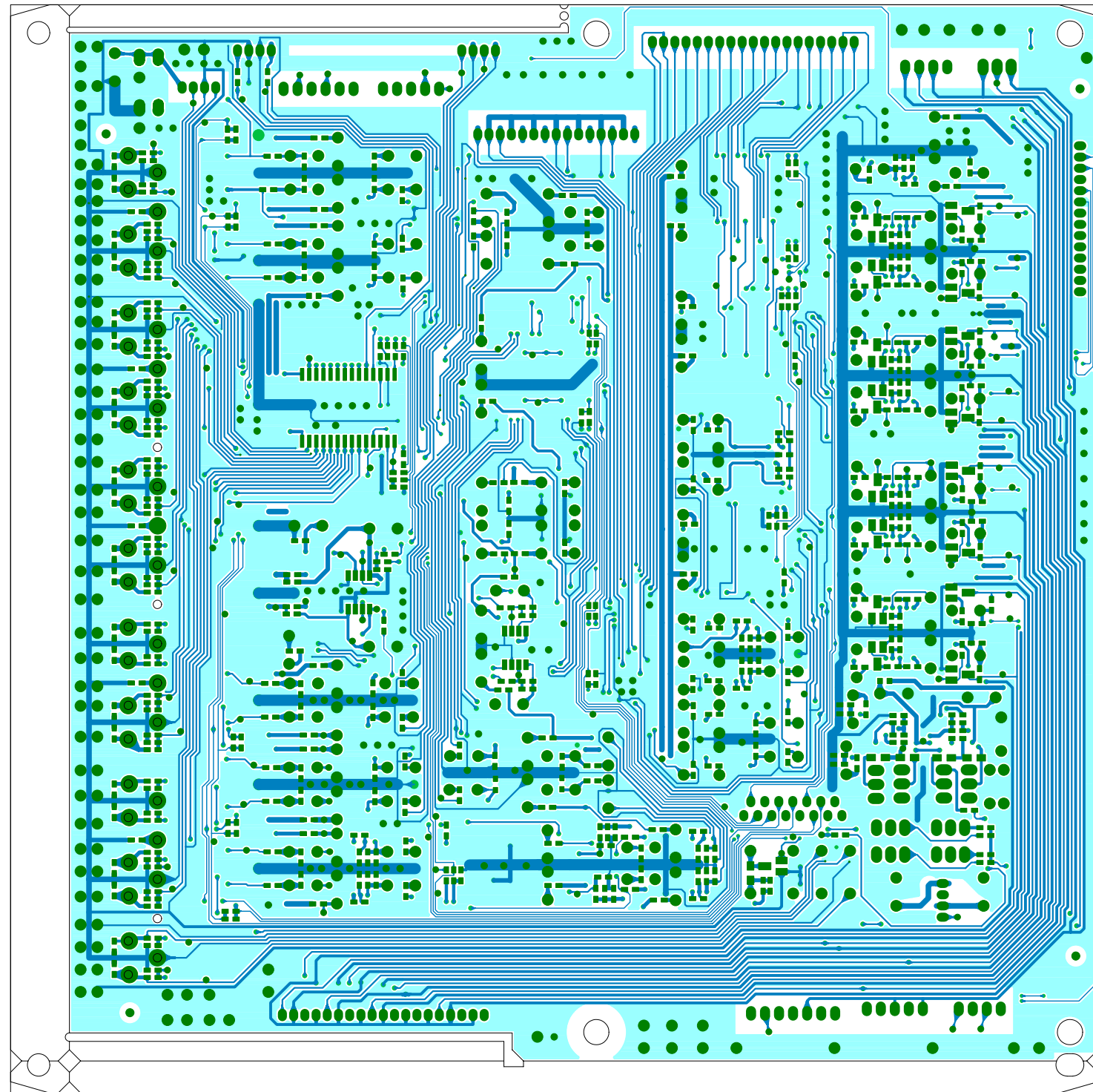

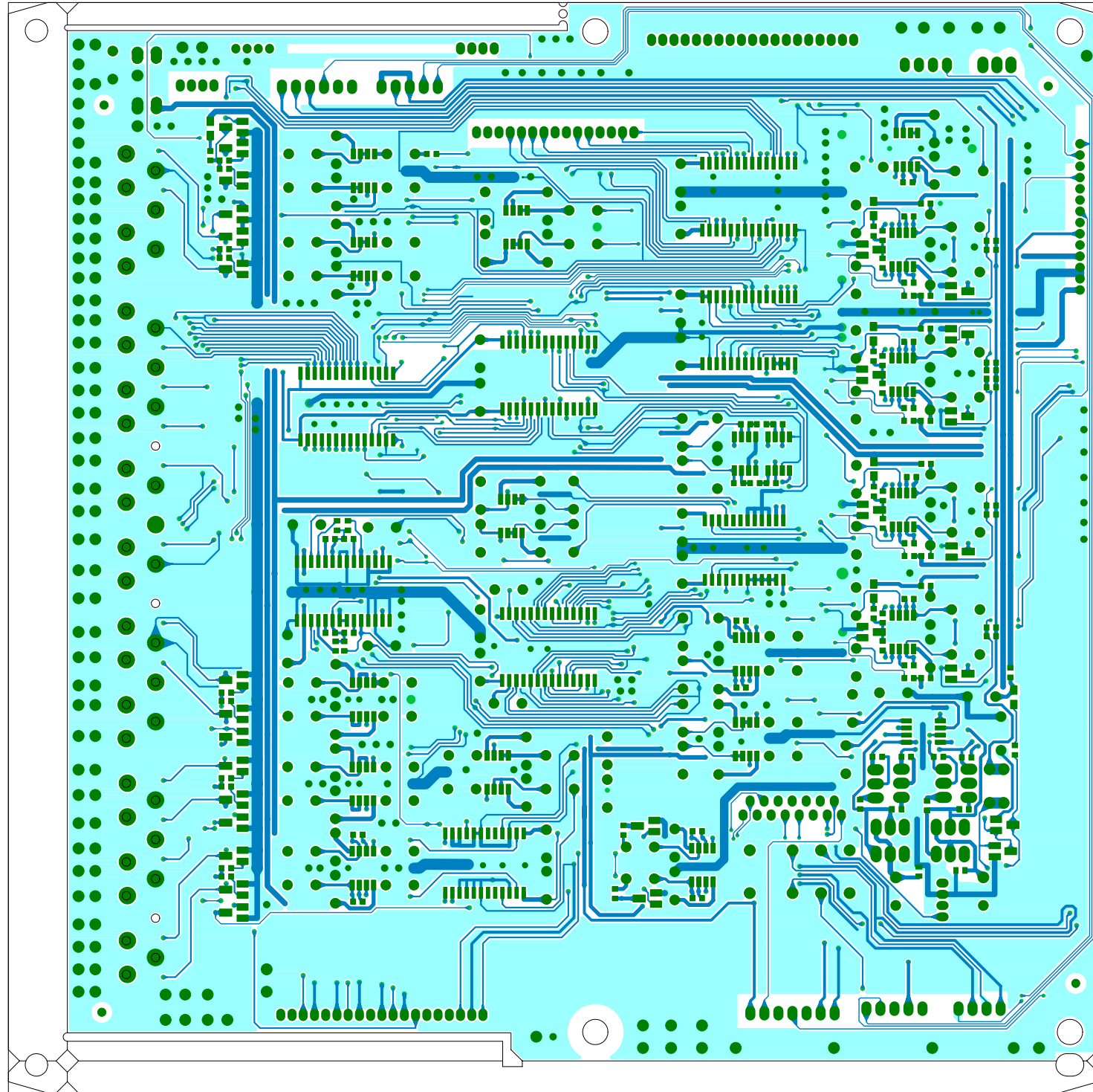





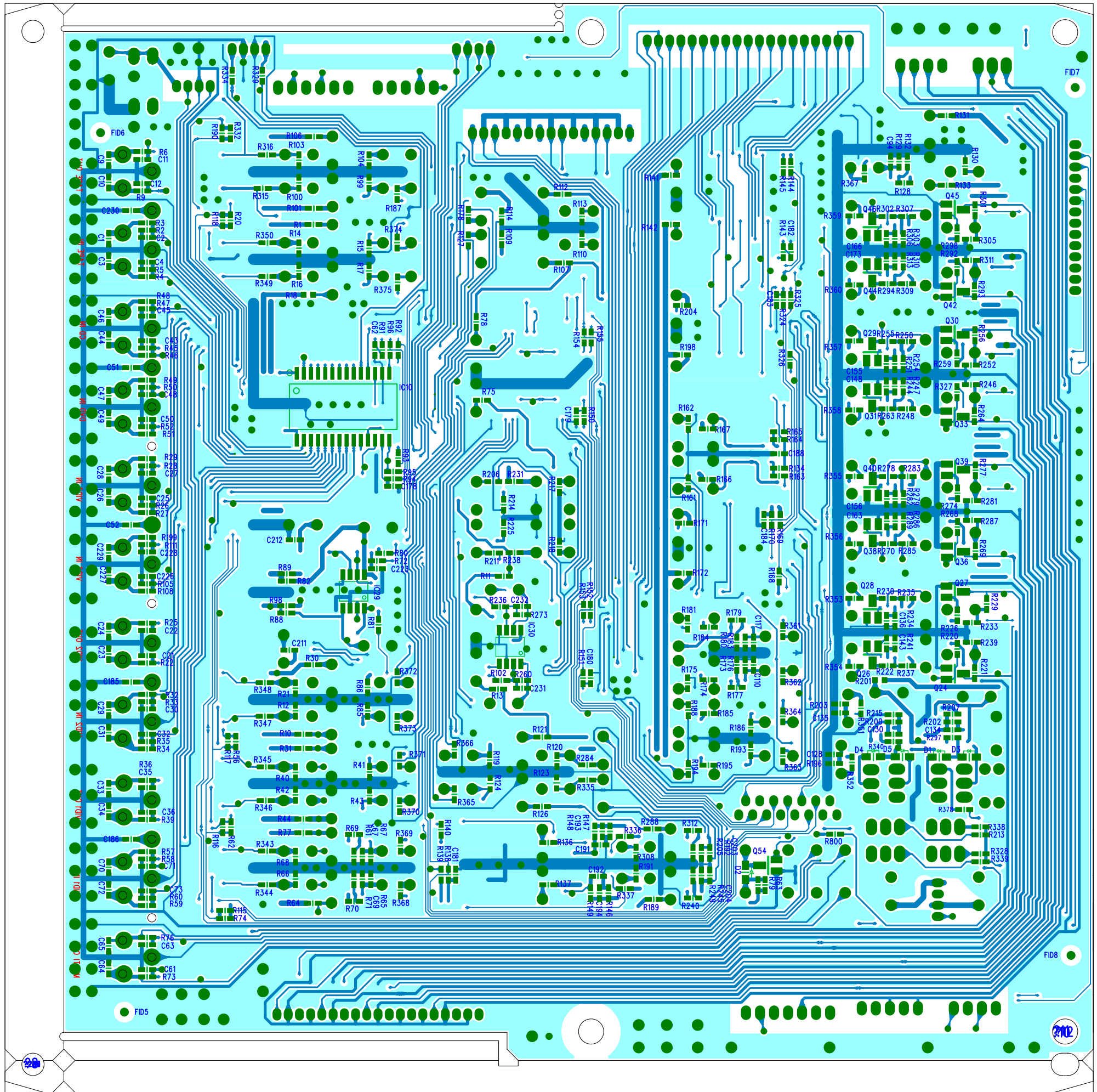

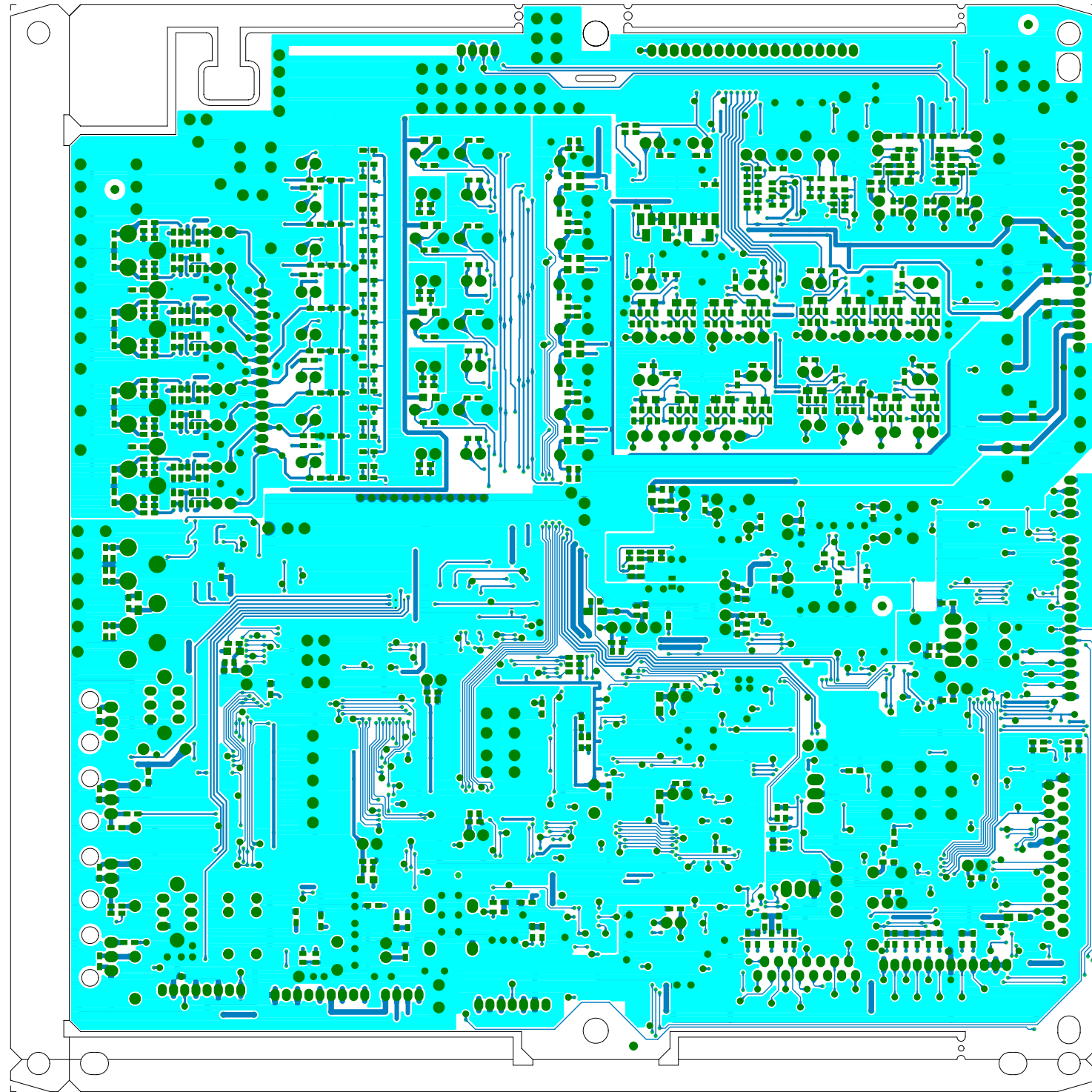

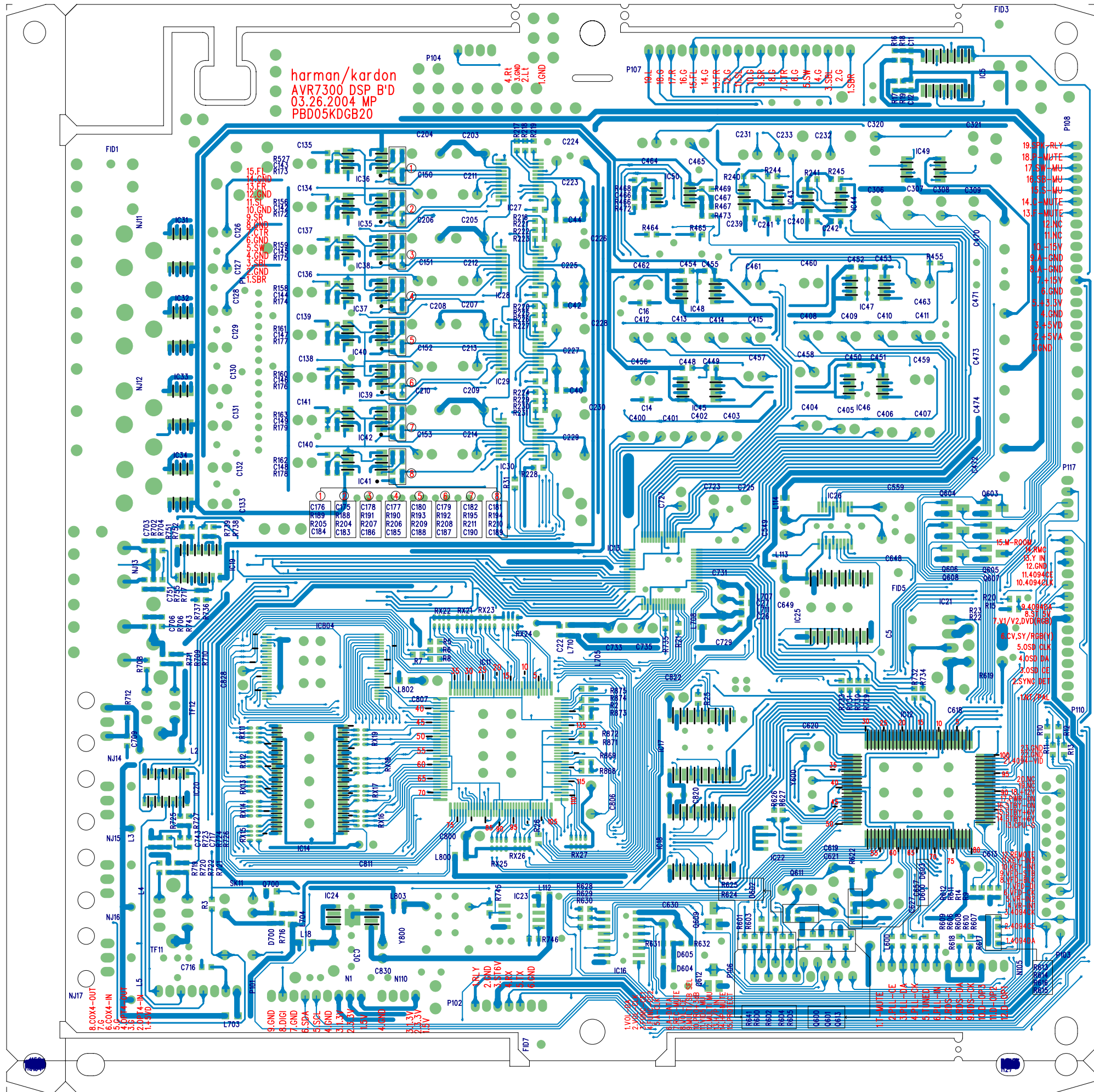



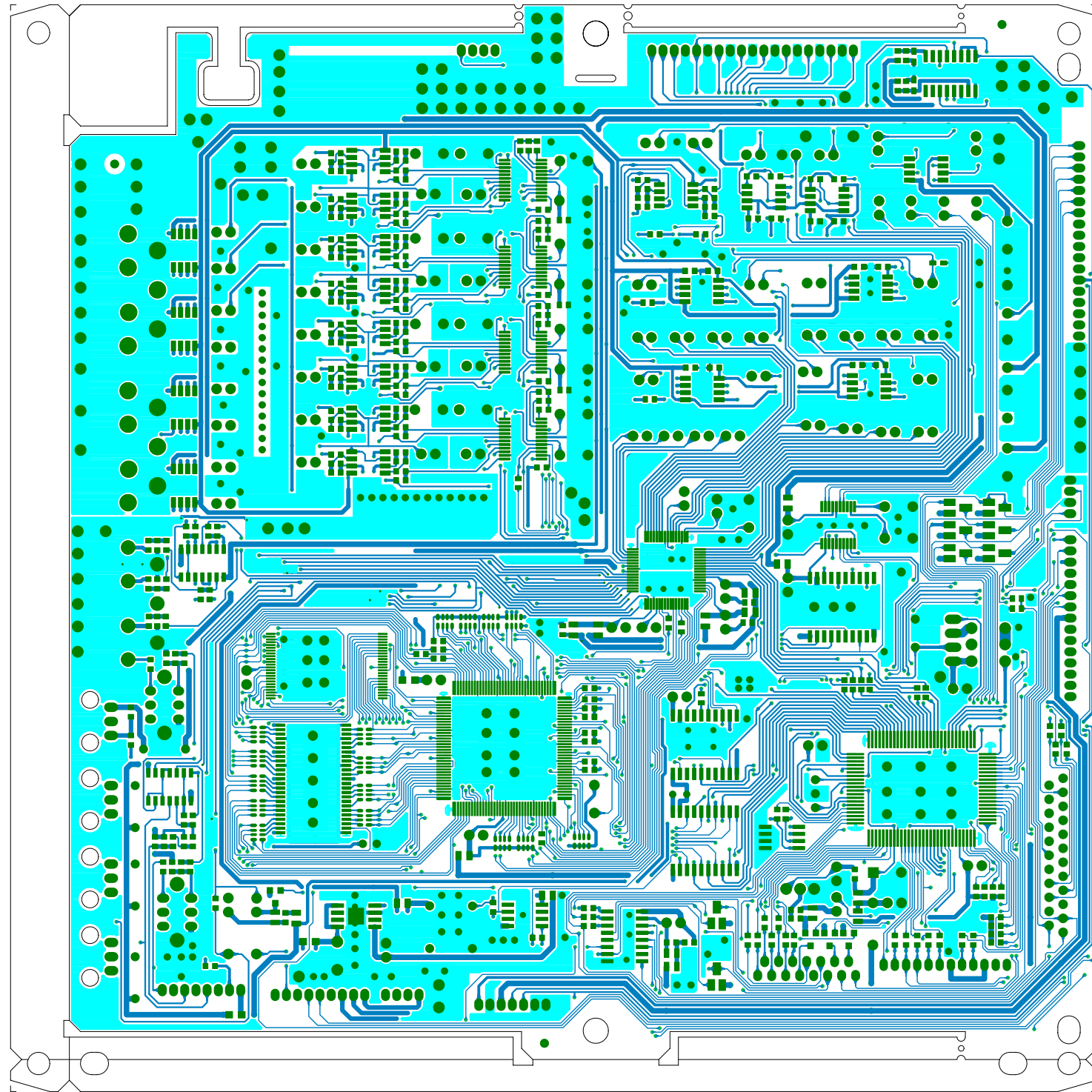

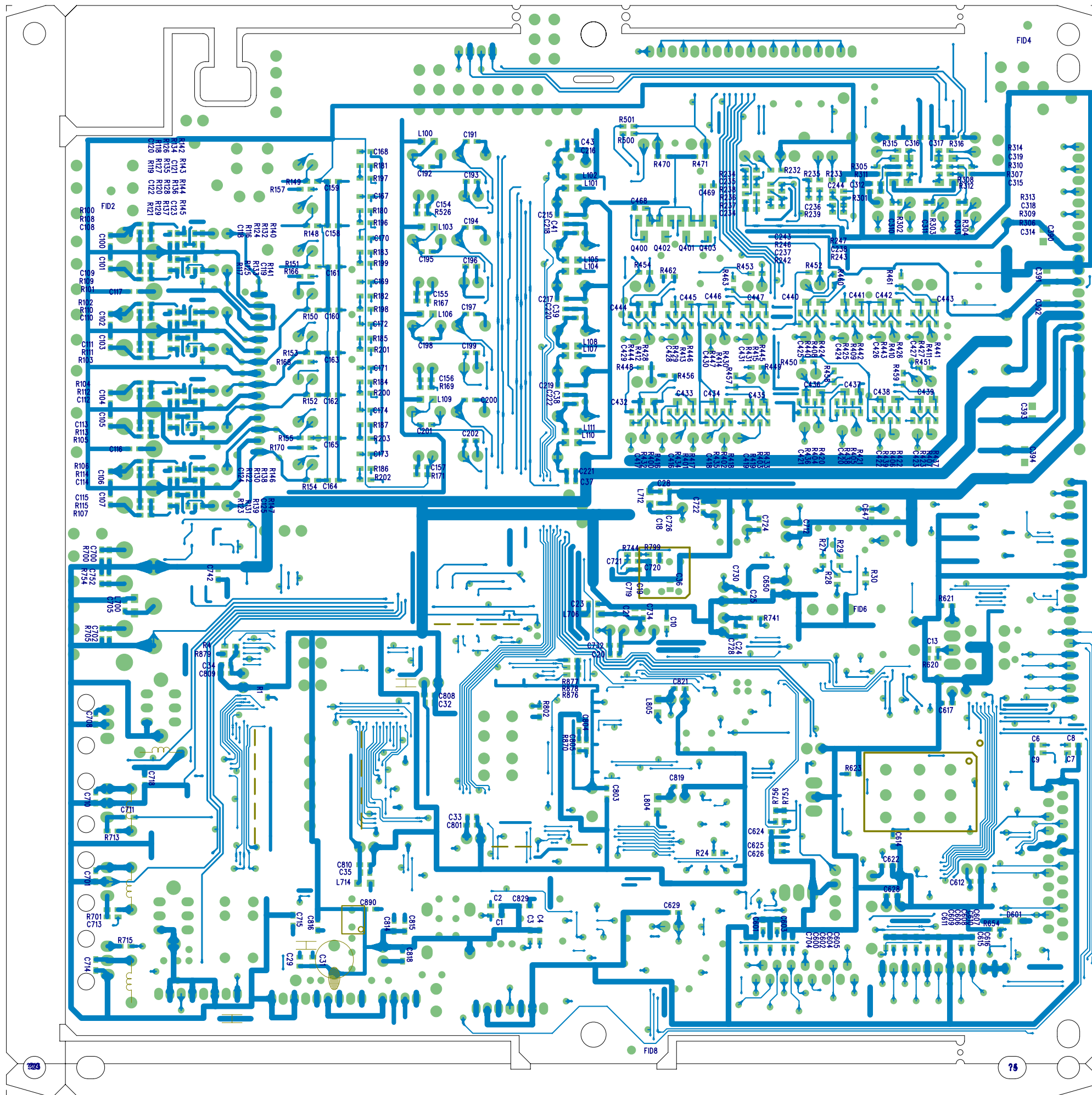



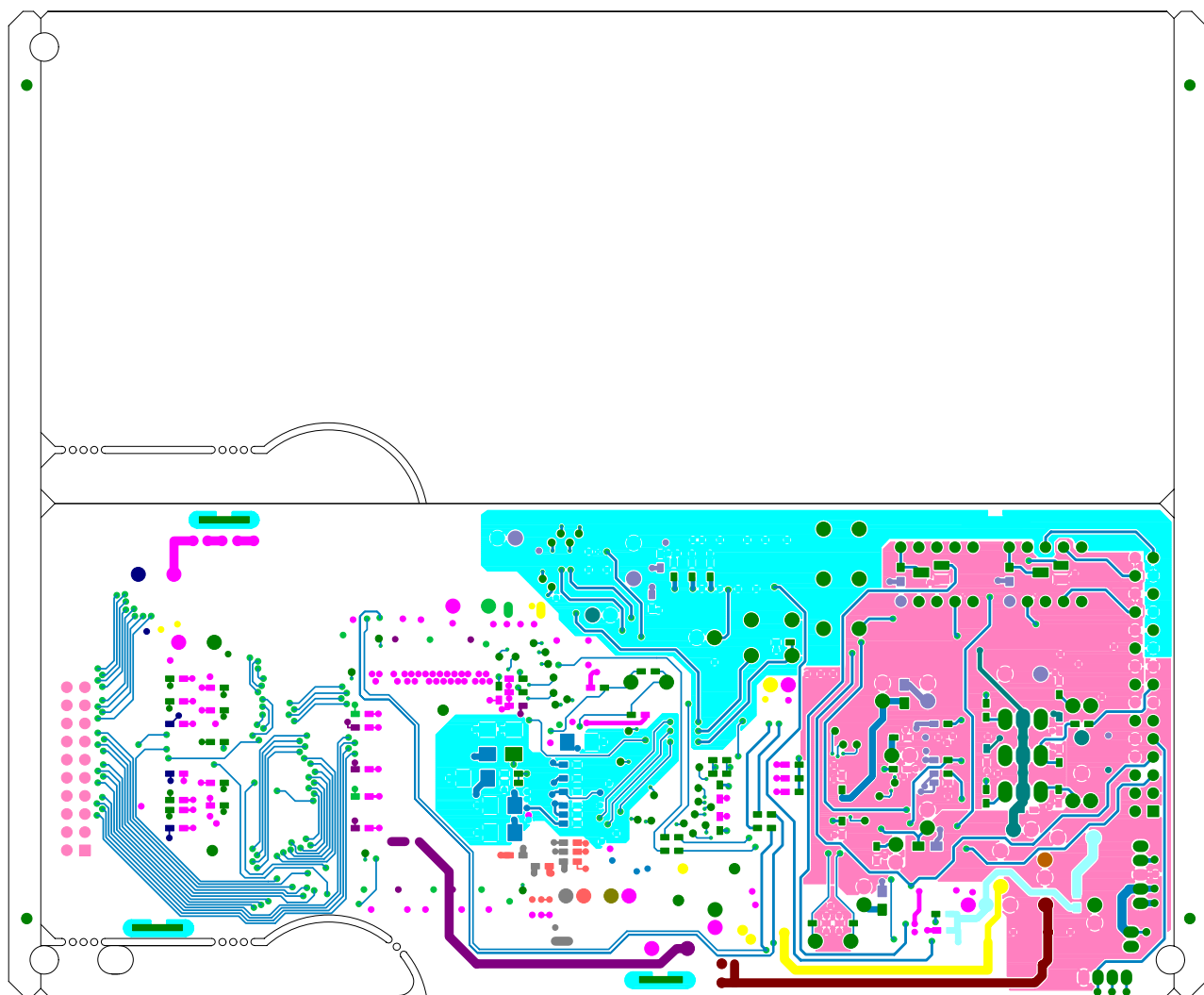

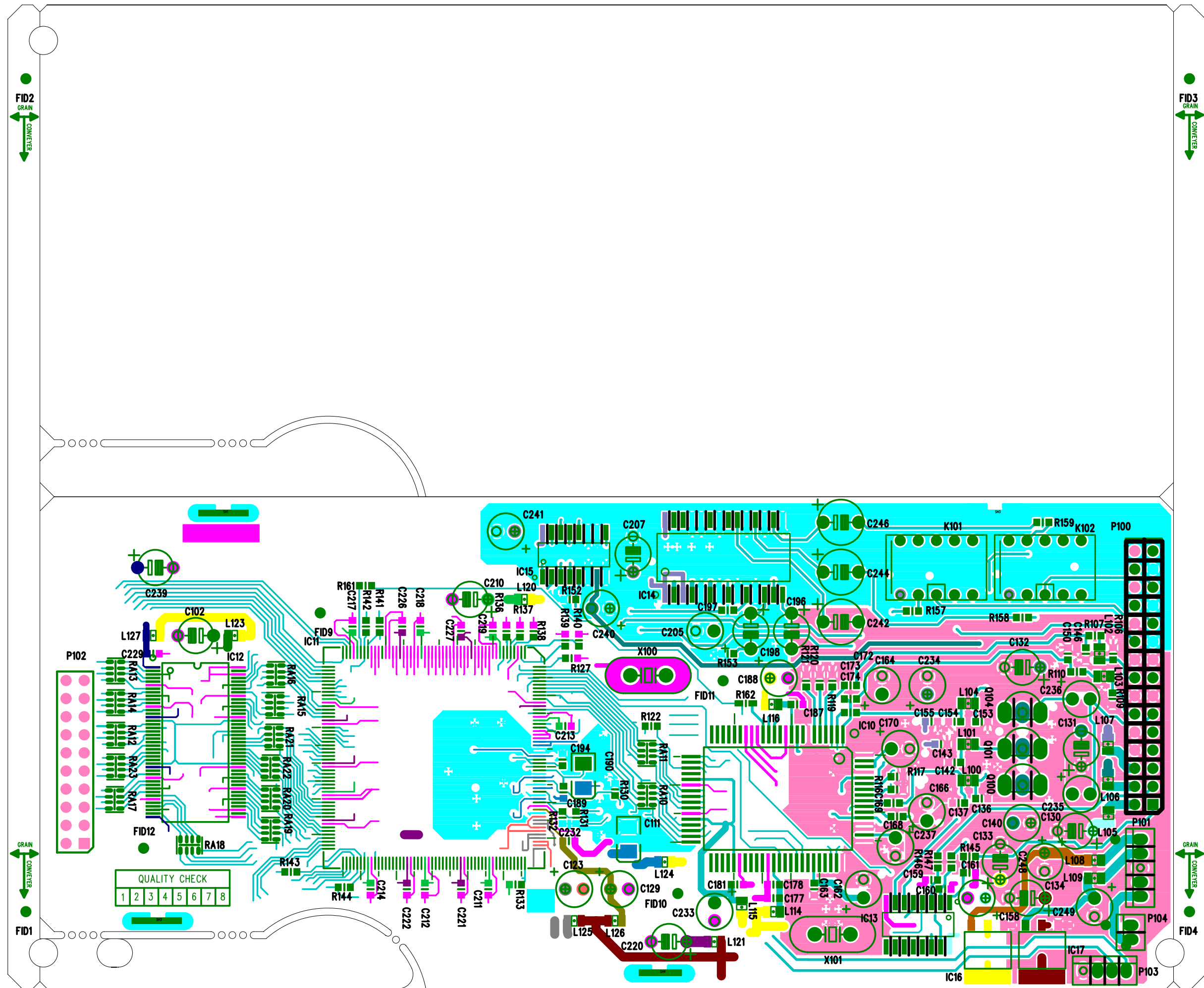

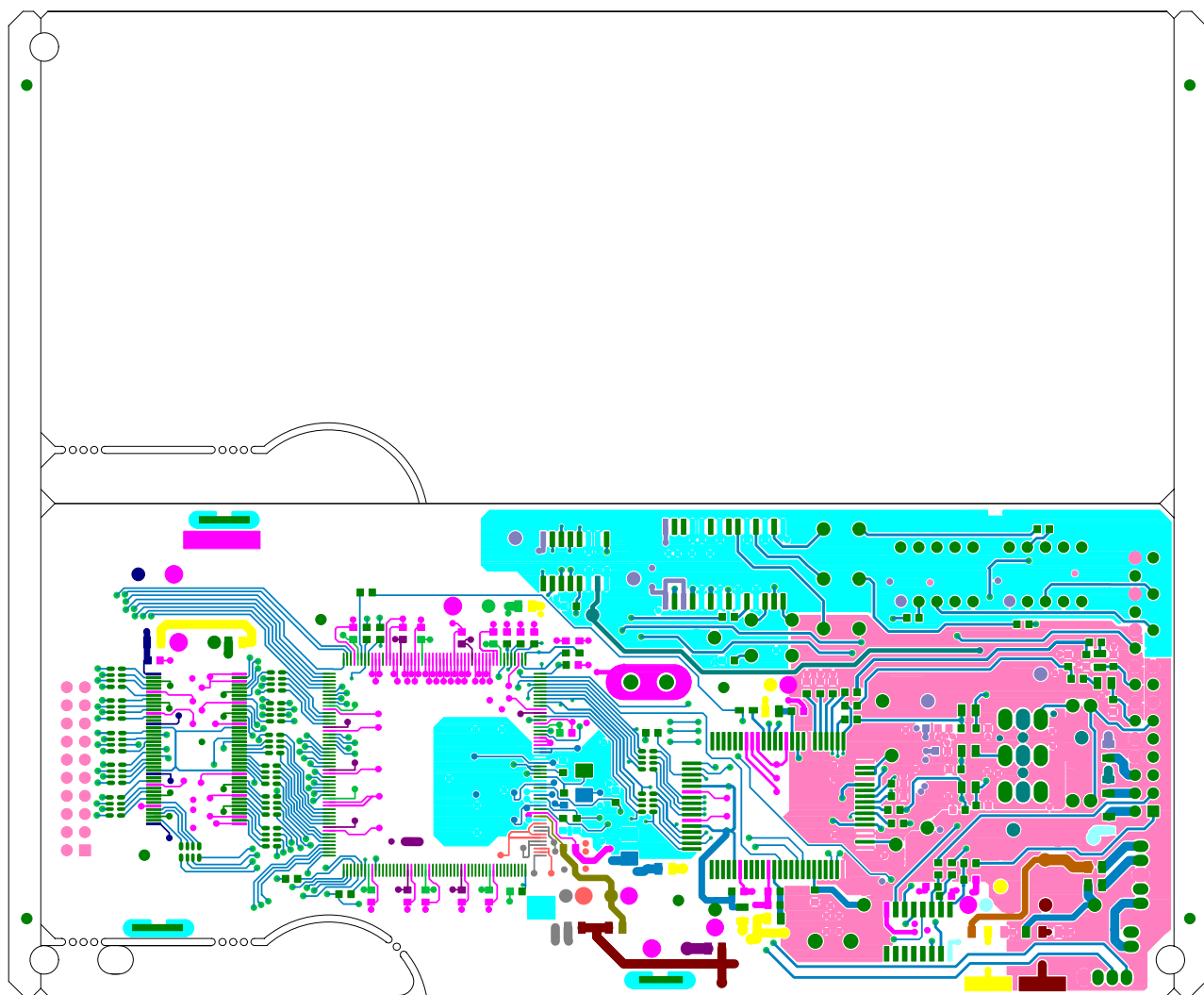

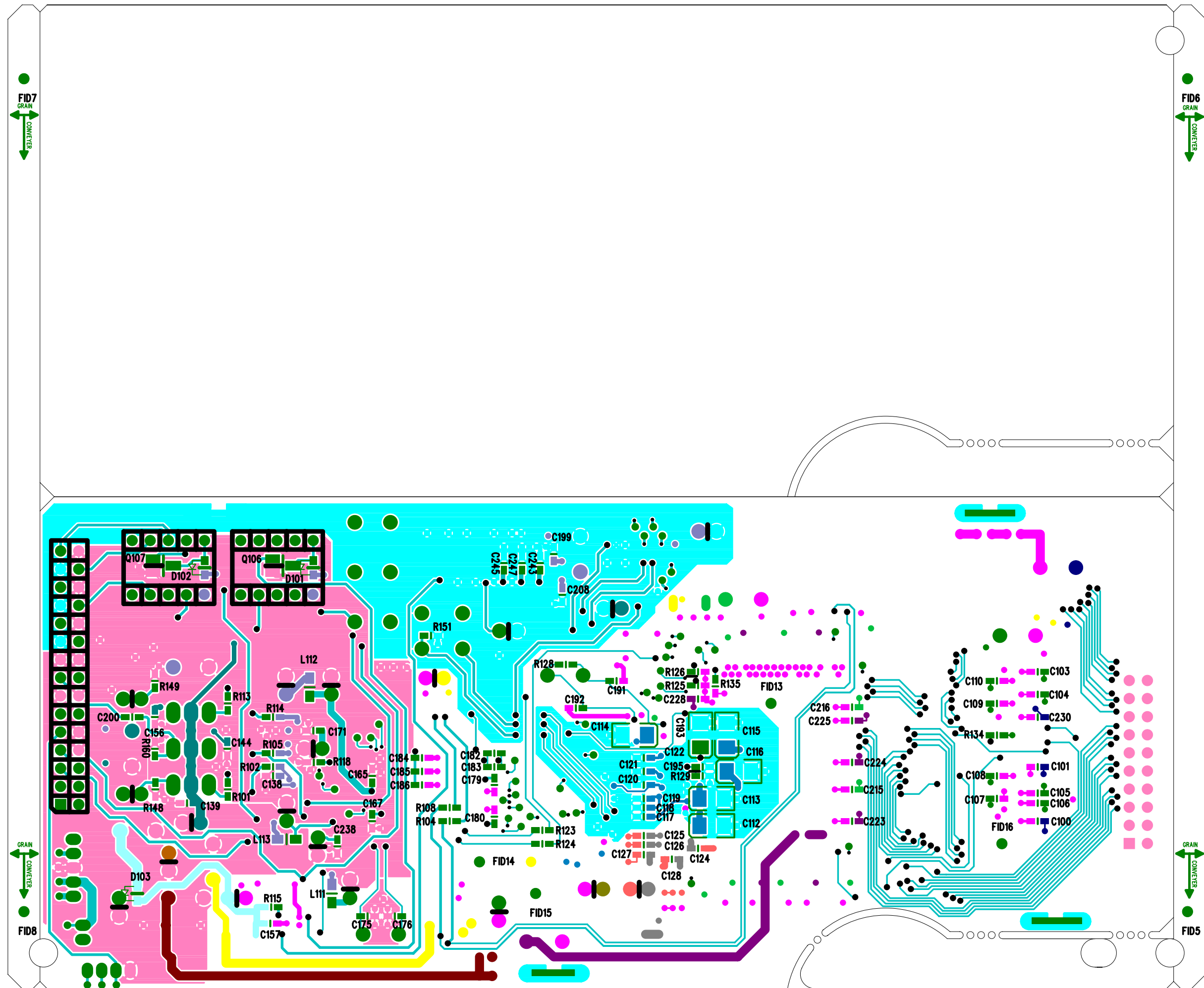

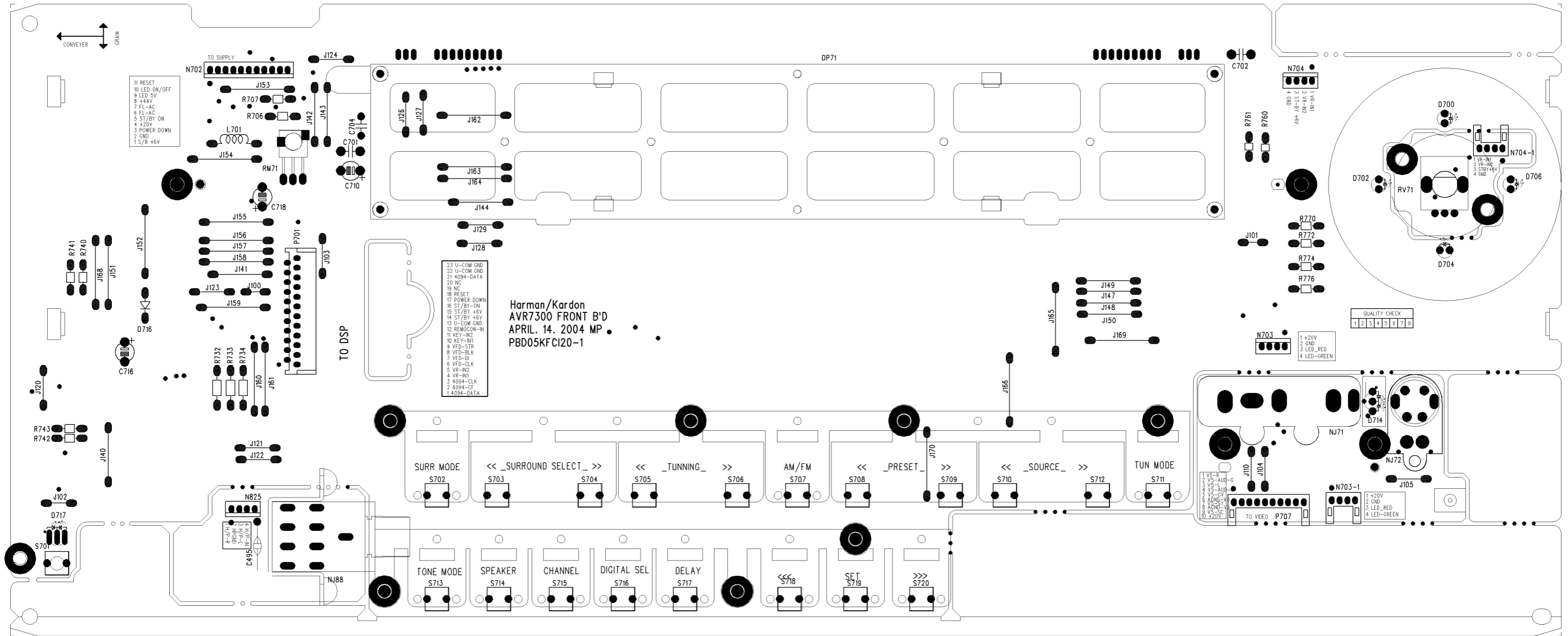

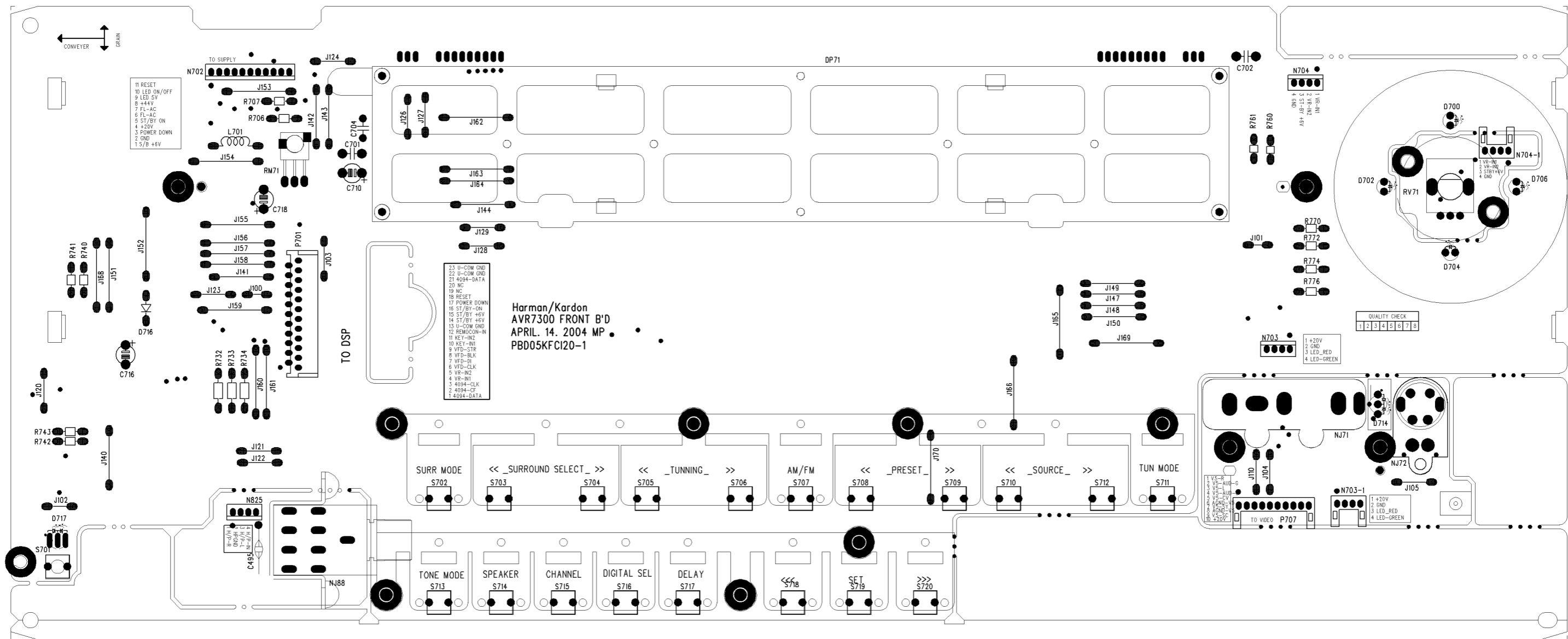

Harman/Kardon  
AVR7300 FRONT B'D  
APRIL. 14. 2004 MP  
PBD05KFC120-1

- 23 U-COM GND
- 22 U-COM GND
- 21 4094-DATA
- 20 NC
- 19 NC
- 18 RESET
- 17 POWER DOWN
- 16 ST/ST-ON
- 15 ST/ST-+6V
- 14 ST/ST-+6V
- 13 U-COM GND
- 12 REMCOM-IN
- 11 KEY-IN2
- 10 KEY-IN1
- 9 VFD-STR
- 8 VFD-BLK
- 7 VFD-DR
- 6 VFD-CLK
- 5 VR-IN2
- 4 VR-IN1
- 3 4094-CLK
- 2 4094-CF
- 1 4094-DATA

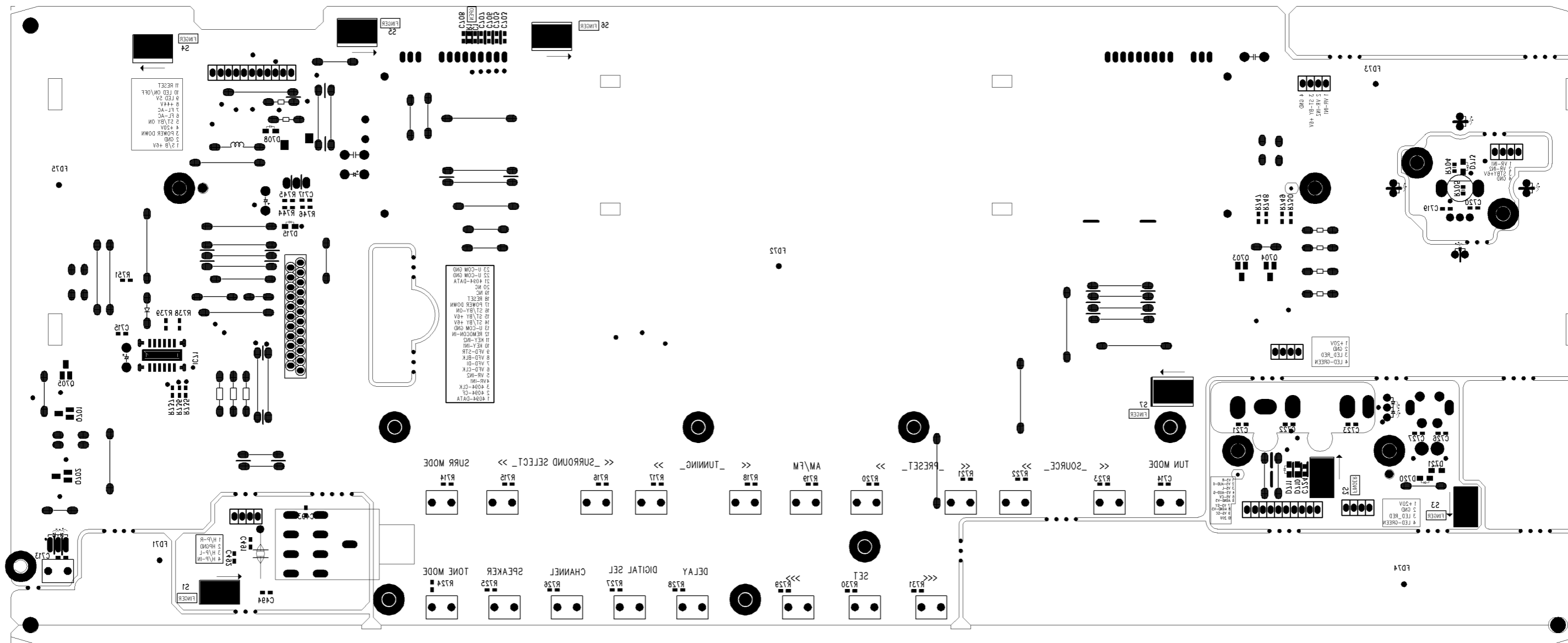





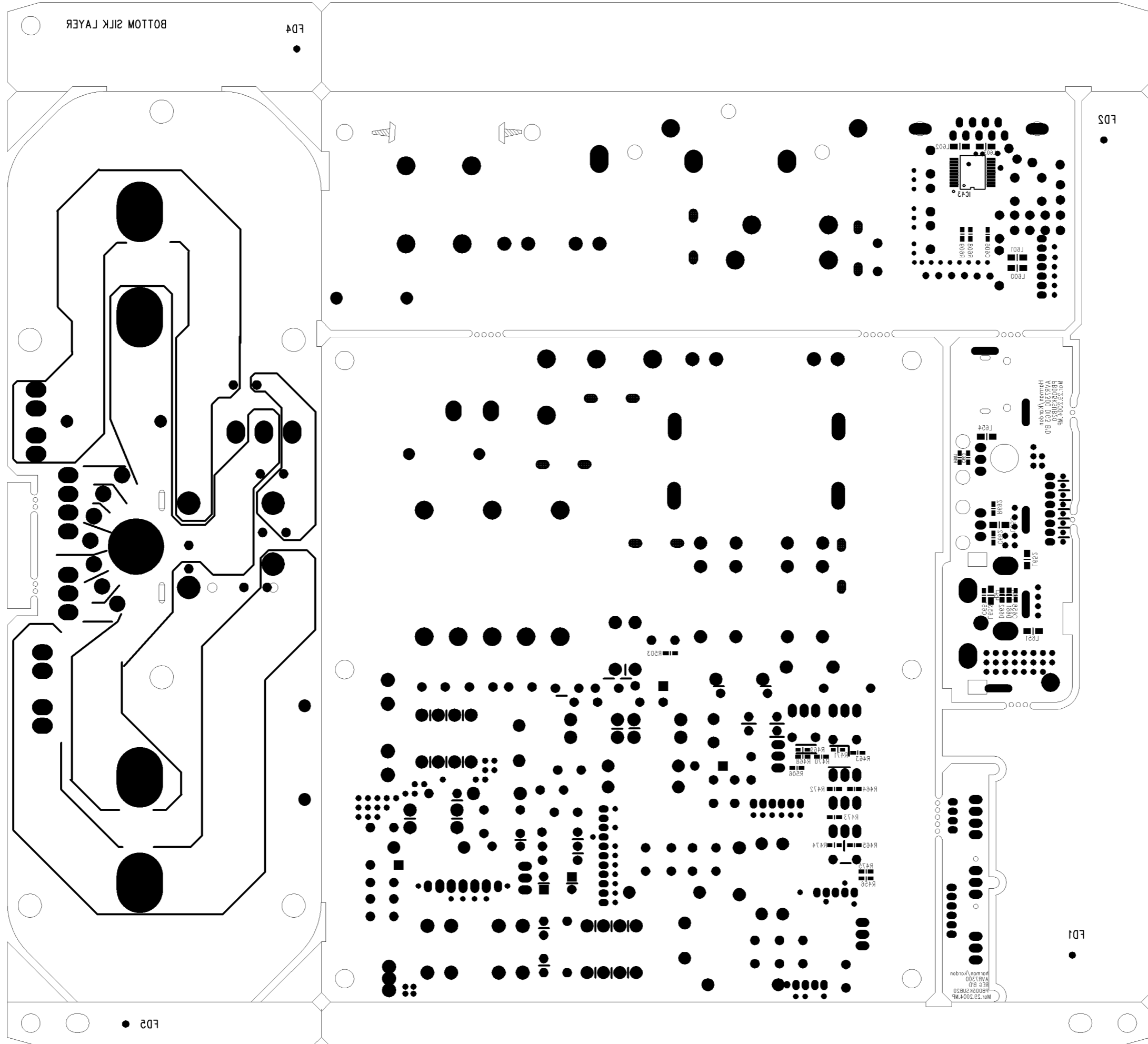



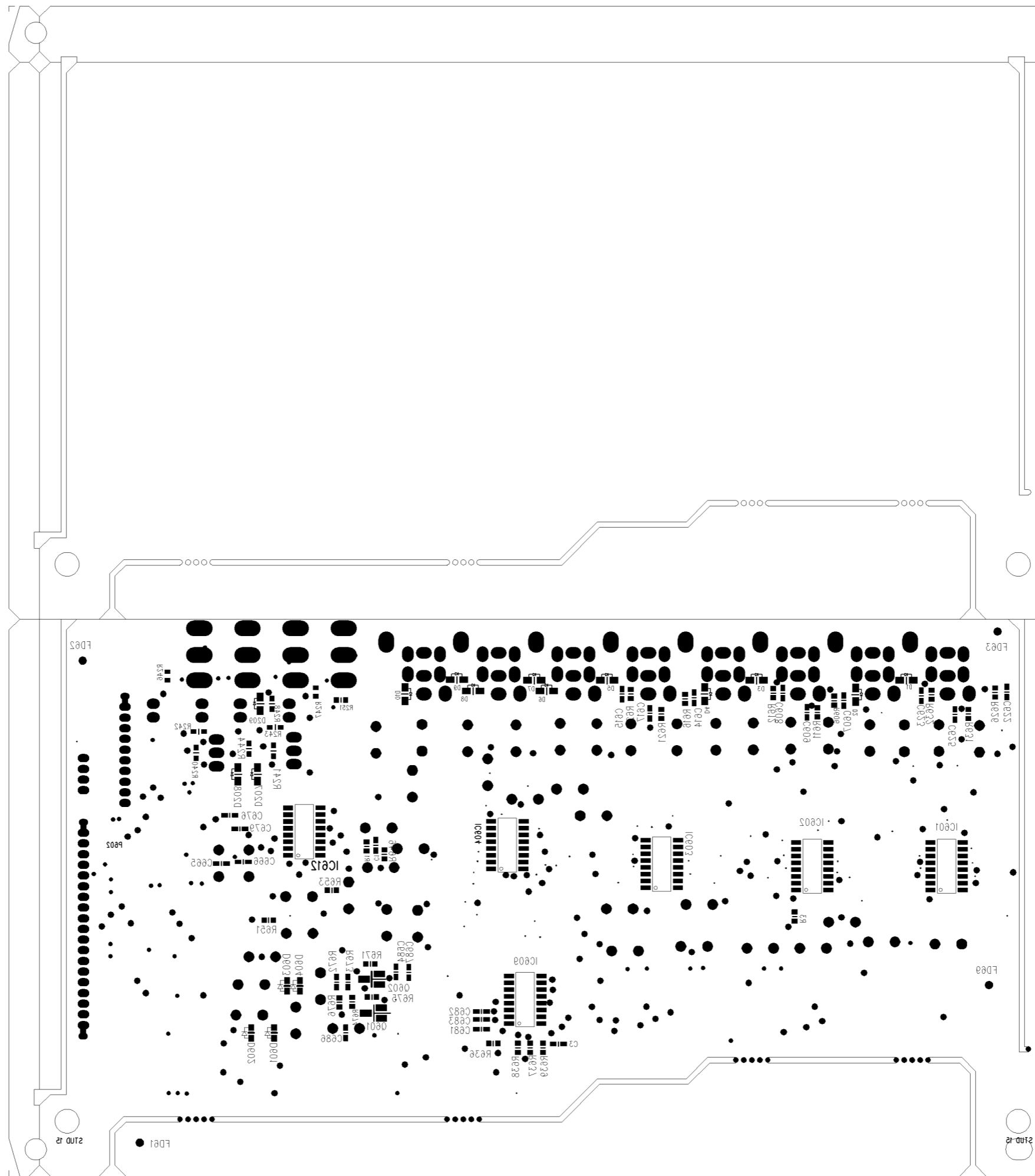

TOP SIDE-SILK

FRONT-L

harman/kardon AVR-7300  
3CH-CON B'D 55559000XX-2  
Aug.09.2003. H02

SURR-L

S-B-L

harman/kardon AVR-7300  
3CH AMP B'D  
MAR 29 2004 MP  
PBD05KA3120

1	2	3	4	5	6	7	8
---	---	---	---	---	---	---	---

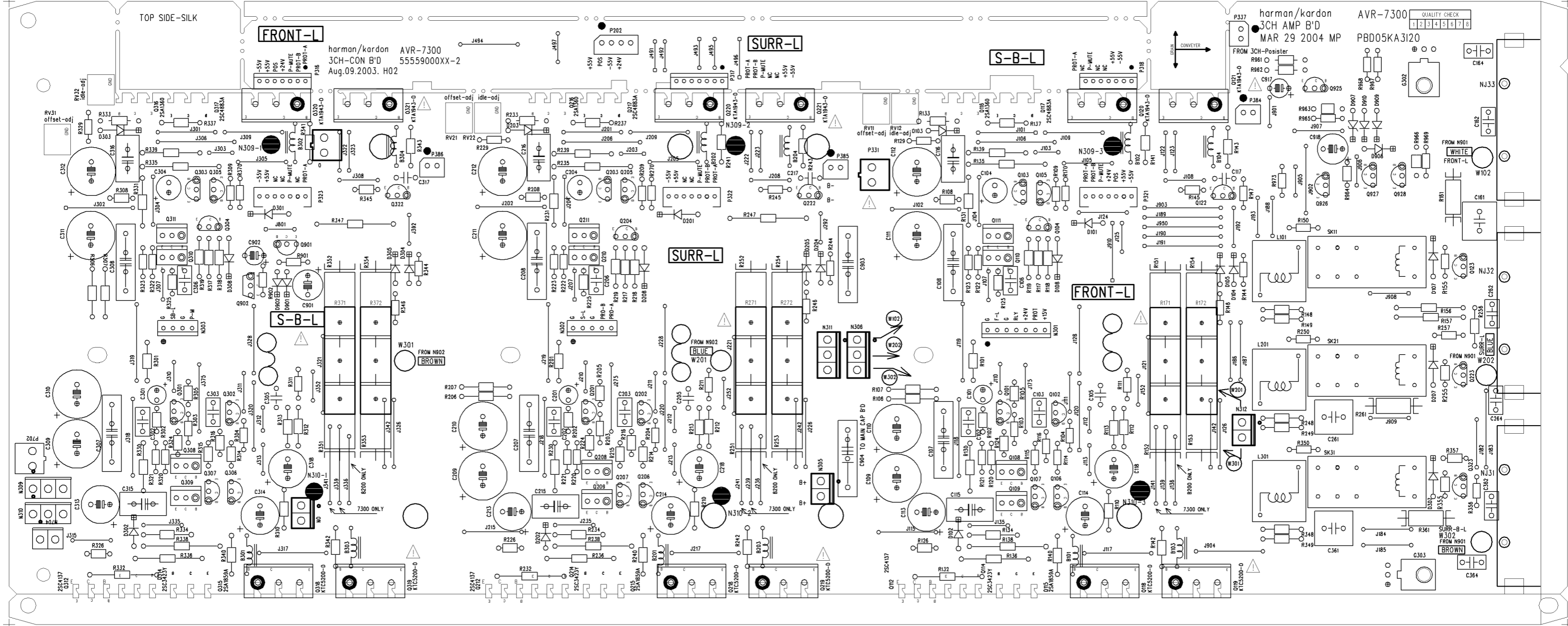

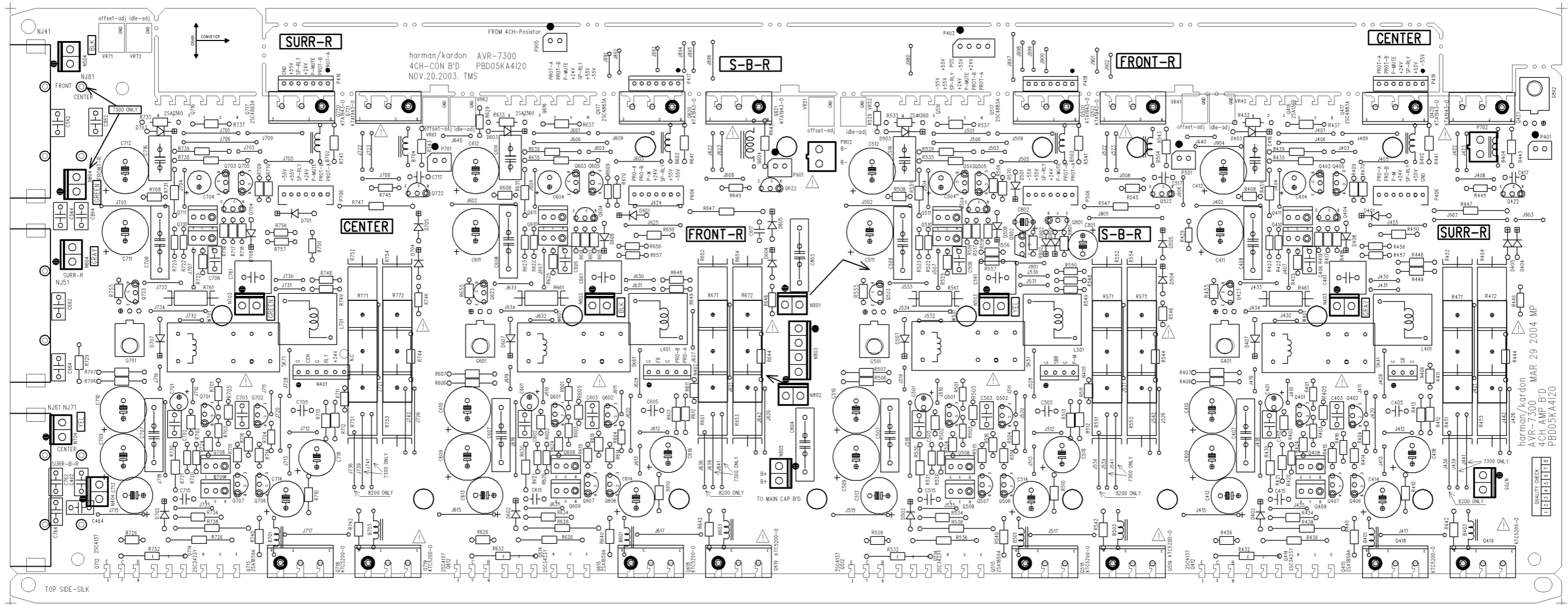

harman/kardon AVR-7300  
4CH-CON B'D PBD05KA4120  
NOV.20.2003. TMS

harman/kardon MAR 29 2004 MP  
AVR-7300  
4CH AMP B'D  
PBD05KA4120

QUALITY CHECK  
1121311111111111

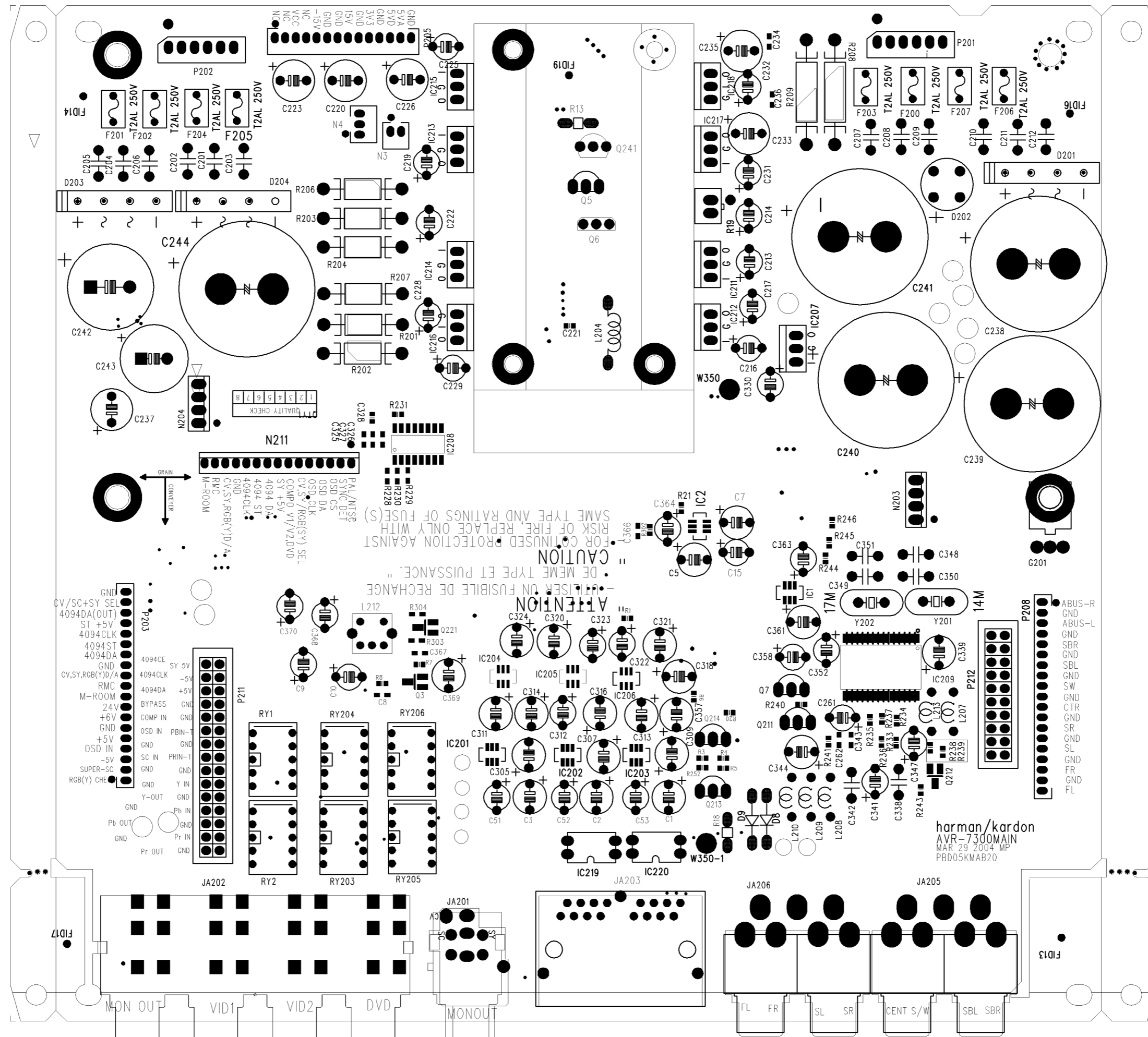

ATTENTION  
 - ATTENSIÓN EN EL REEMPLAZO  
 " CAUTION  
 . DE MEME TYPE ET PUISSANCE."  
 FOR CONTINUED PROTECTION AGAINST  
 RISK OF FIRE, REPLACE ONLY WITH  
 SAME TYPE AND RATINGS OF FUSE(S)

- |                 |         |         |
|-----------------|---------|---------|
| GND             | 4094CE  | SY 5V   |
| CV/SC+SY SEL    | 4094CLK | -5V     |
| 4094DA(OUT)     | 4094DA  | +5V     |
| ST +5V          | BYPASS  | GND     |
| 4094CLK         | 24V     | GND     |
| 4094ST          | +6V     | COMP IN |
| 4094DA          | GND     | OSD IN  |
| GND             | GND     | PBIN-T  |
| CV,SY,RGB(Y)D/A | GND     | SC IN   |
| RMC             | GND     | PRIN-T  |
| M-ROOM          | GND     | GND     |
| 24V             | GND     | Y IN    |
| +6V             | GND     | Y-OUT   |
| GND             | GND     | Pb IN   |
| +5V             | GND     | Pb OUT  |
| OSD IN          | GND     | GND     |
| -5V             | GND     | Pr IN   |
| SUPER-SC        | GND     | Pr OUT  |
| RGB(Y) CHE      | GND     | GND     |

harman/kardon  
 AVR-7300MAIN  
 MAR 29 2004 MP  
 PBD05KMAB20

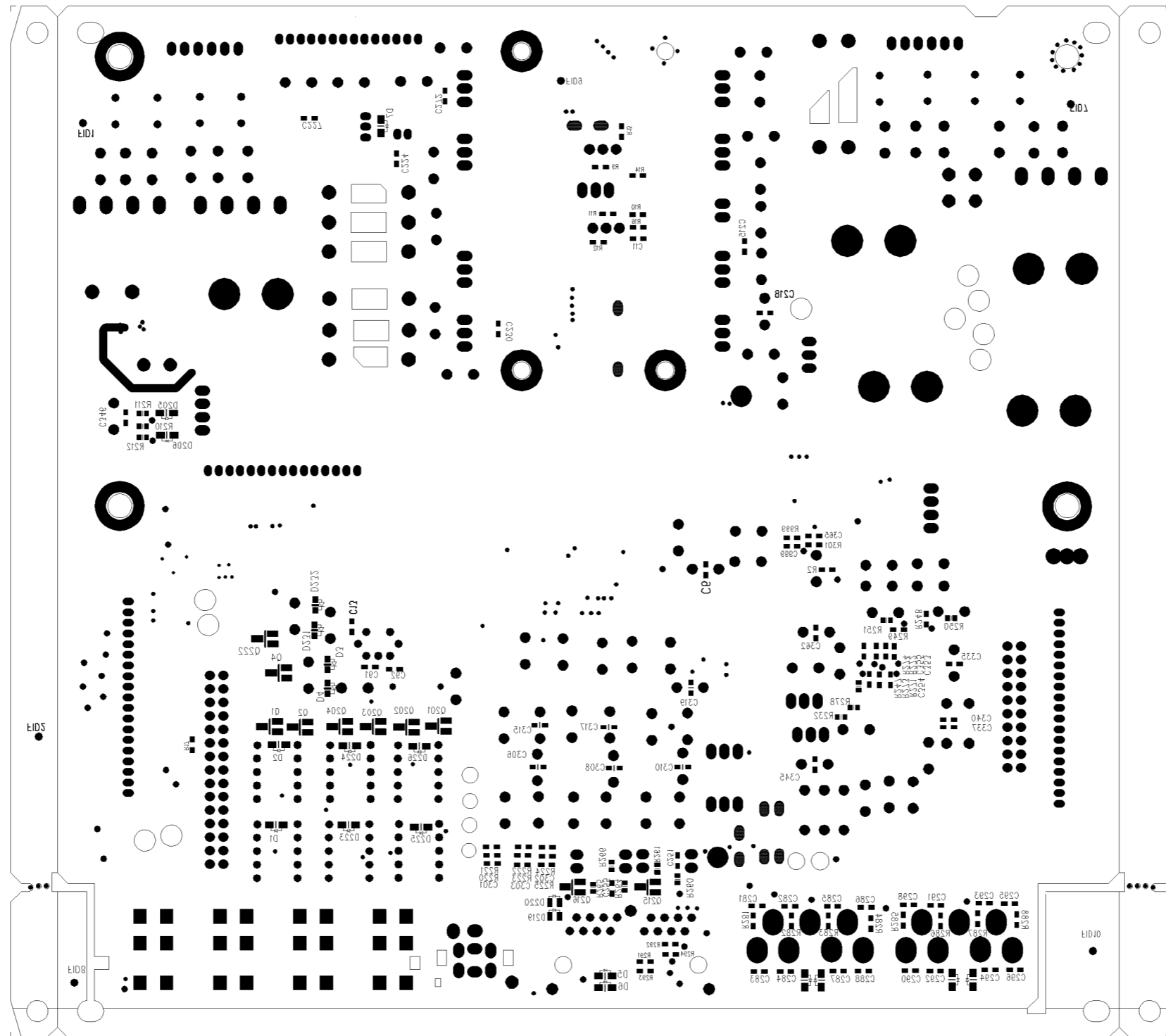

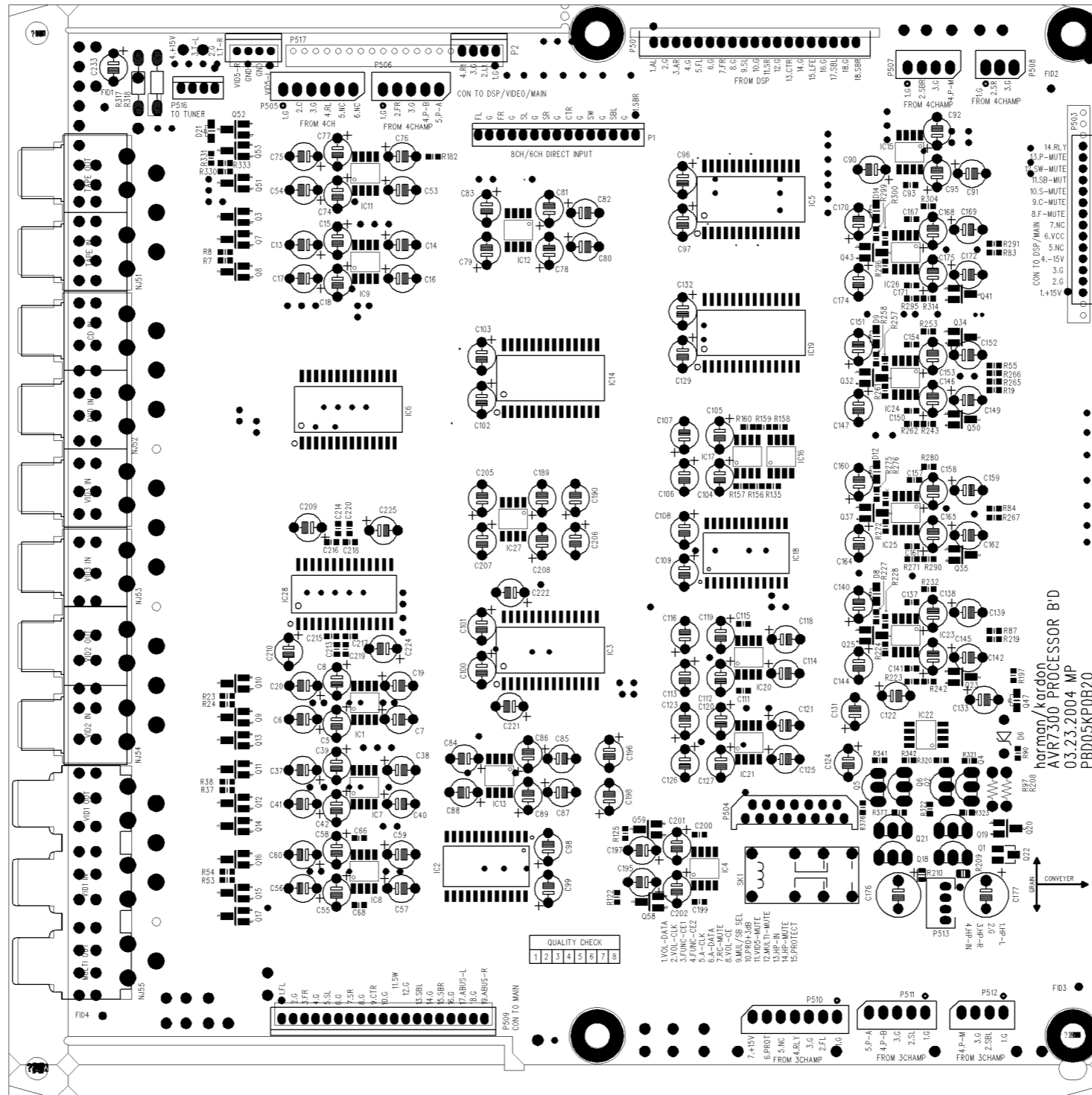



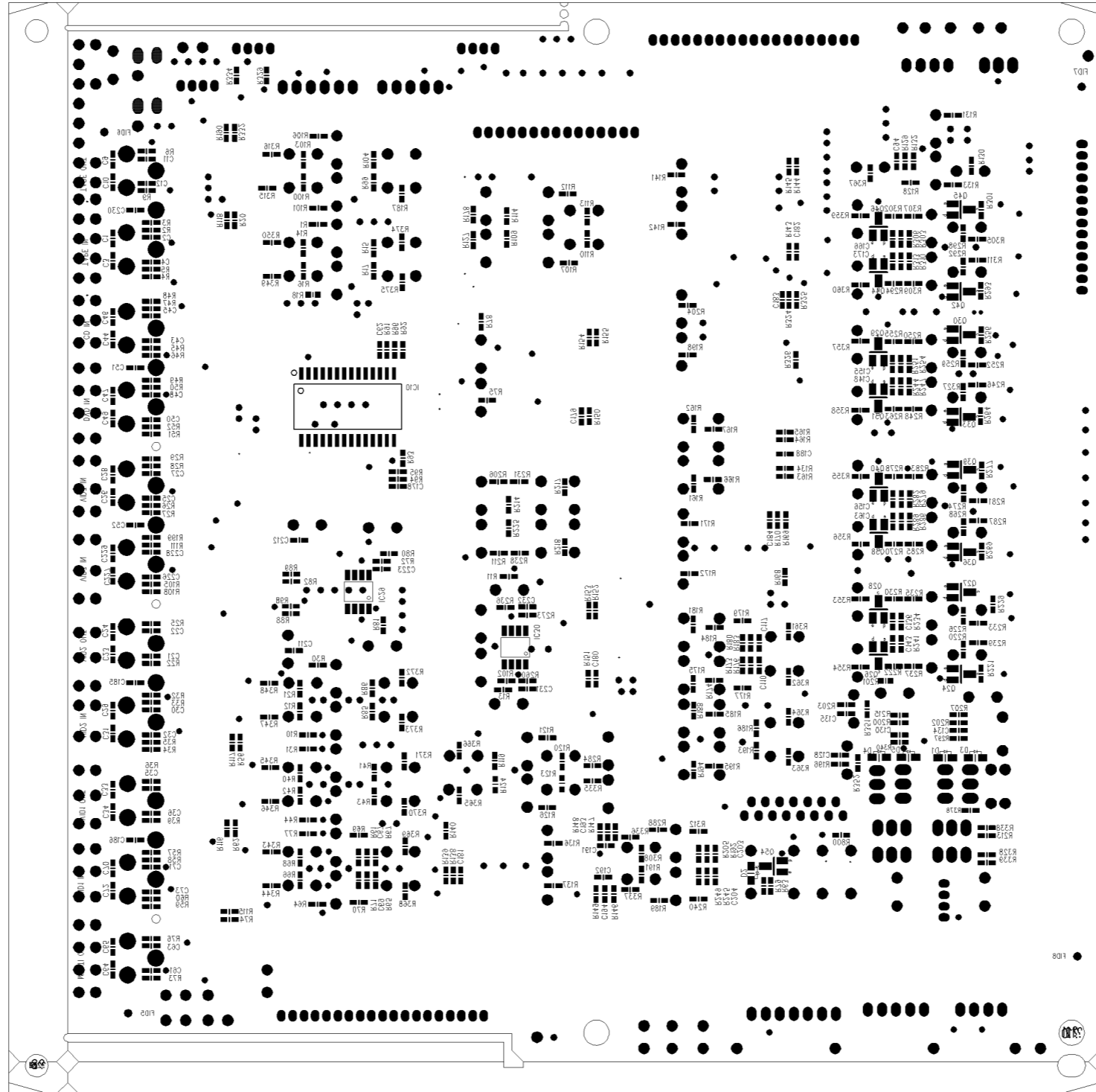



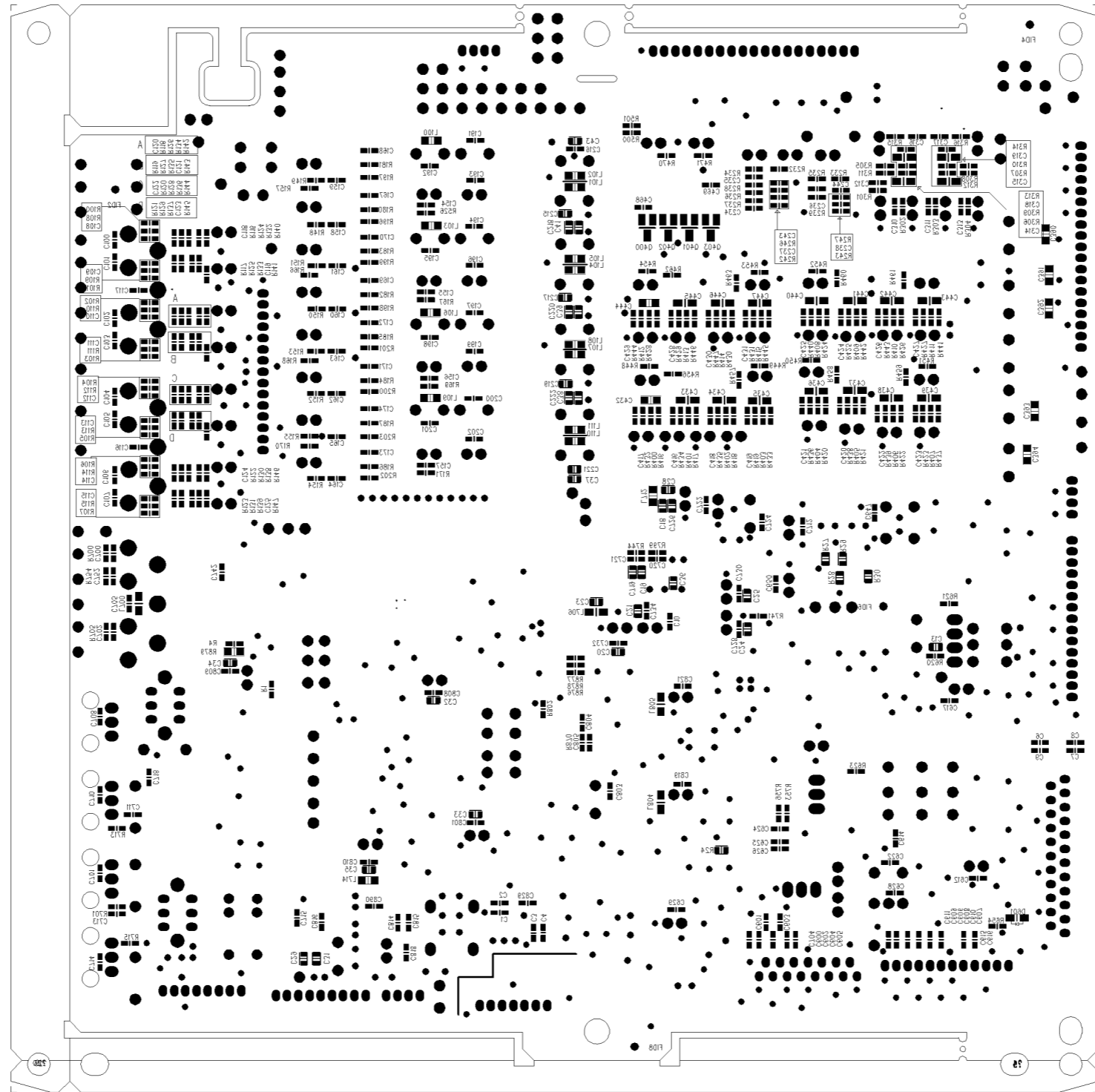

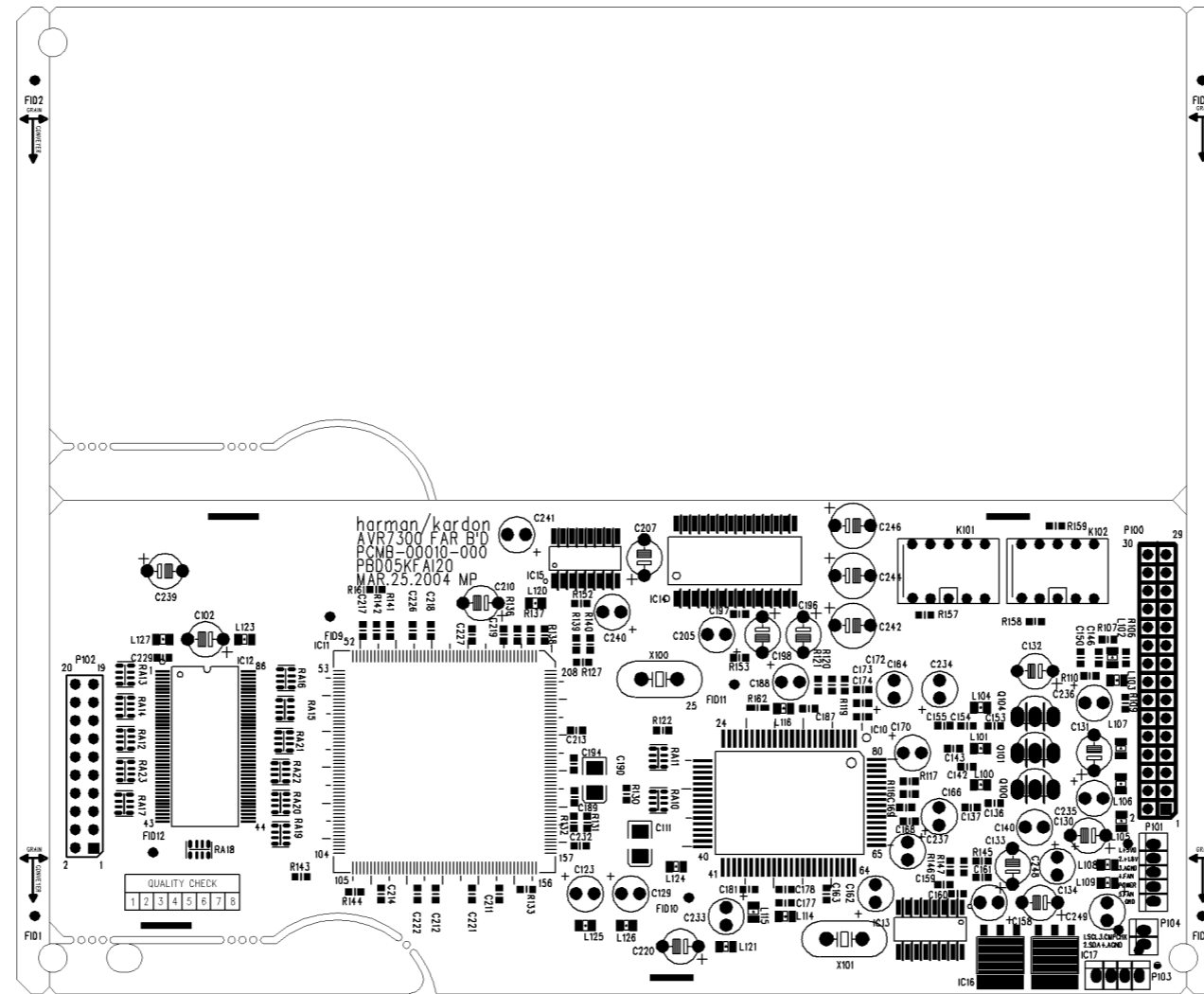

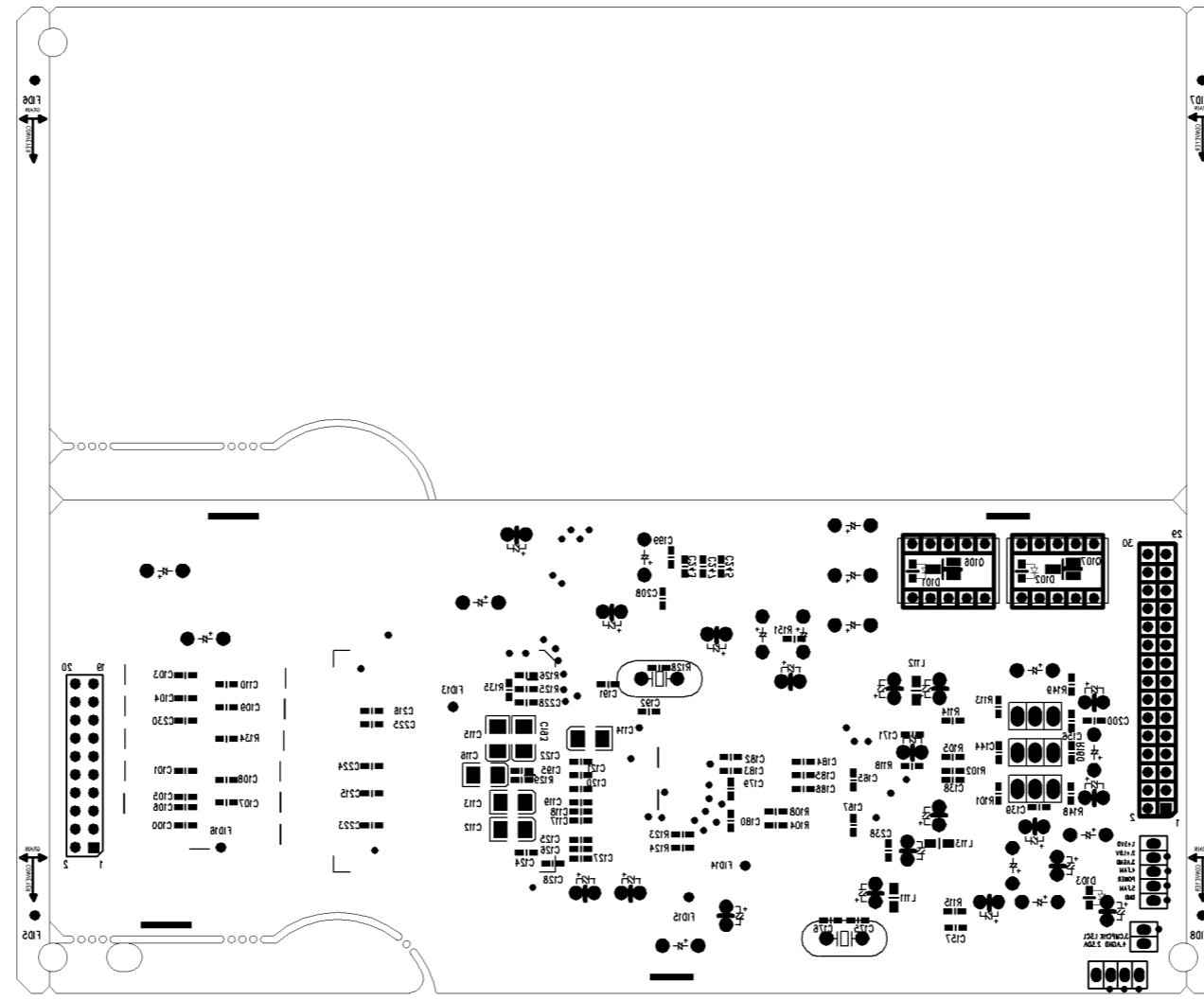

# SCHEMATIC DIAGRAM

harman/kardon  
AVR7300 DSP1

REVISION RECORD		
NO.	Date	Contents

IC16 (4094) TABLE			
Q1	MULTI/SB SEL	Q5	OPT3/D-TUNER SEL
Q2	PROLOGIC 3dB	Q6	SPR. NLT
Q3		Q7	RSRV12.DVD/VIDEO SEL
Q4	VIDEOS MUTE	Q8	CV/SY/RSBE(Y) SEL

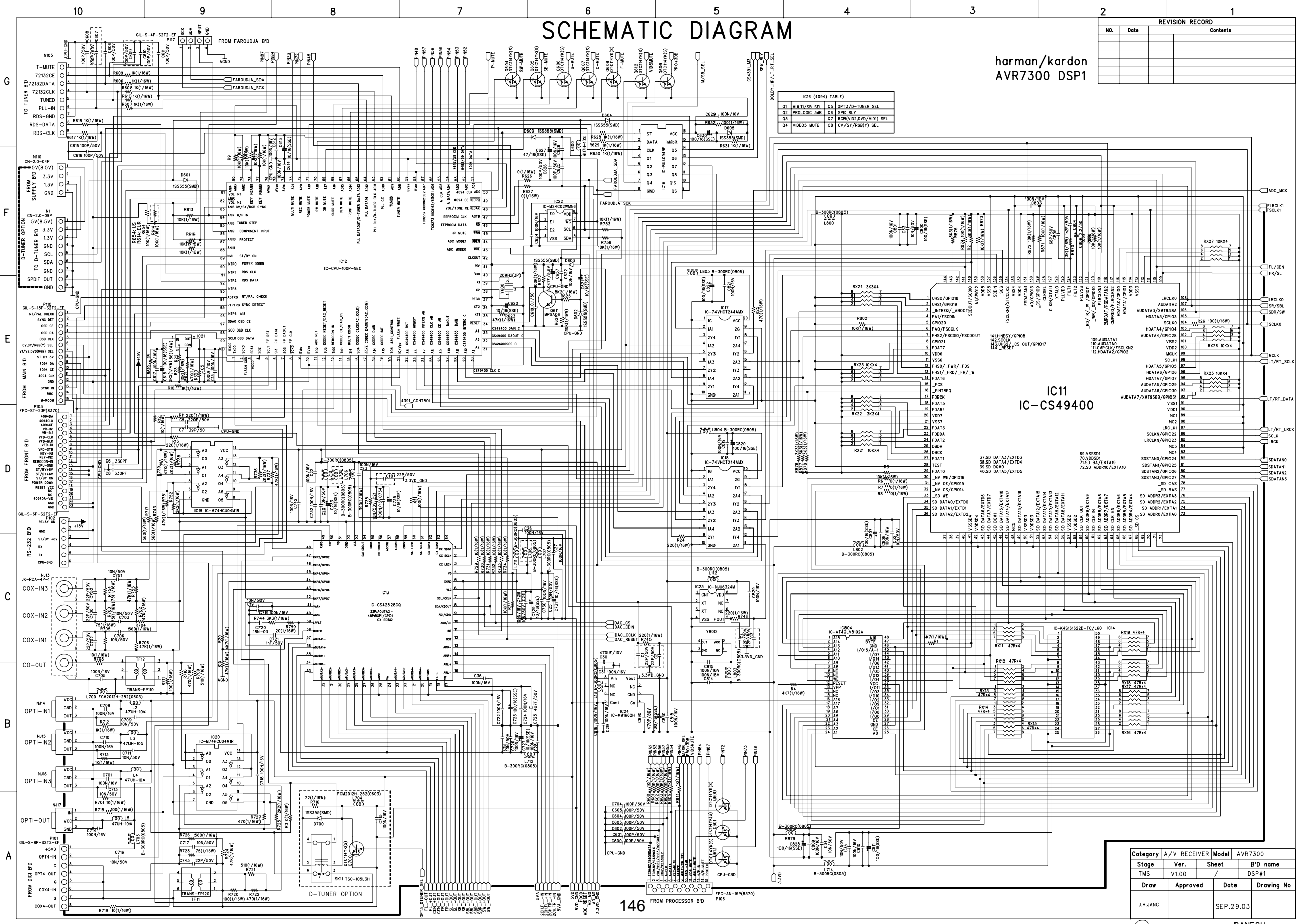

Category	A/V RECEIVER	Model	AVR7300
Stage	Ver.	Sheet	B'D name
TMS	V1.00	/	DSP#1
Draw	Approved	Date	Drawing No
J.H.JANG		SEP.29.03	

# SCHEMATIC DIAGRAM

harman/kardon  
AVR7300 DSP2

REVISION RECORD		
NO.	Date	Contents

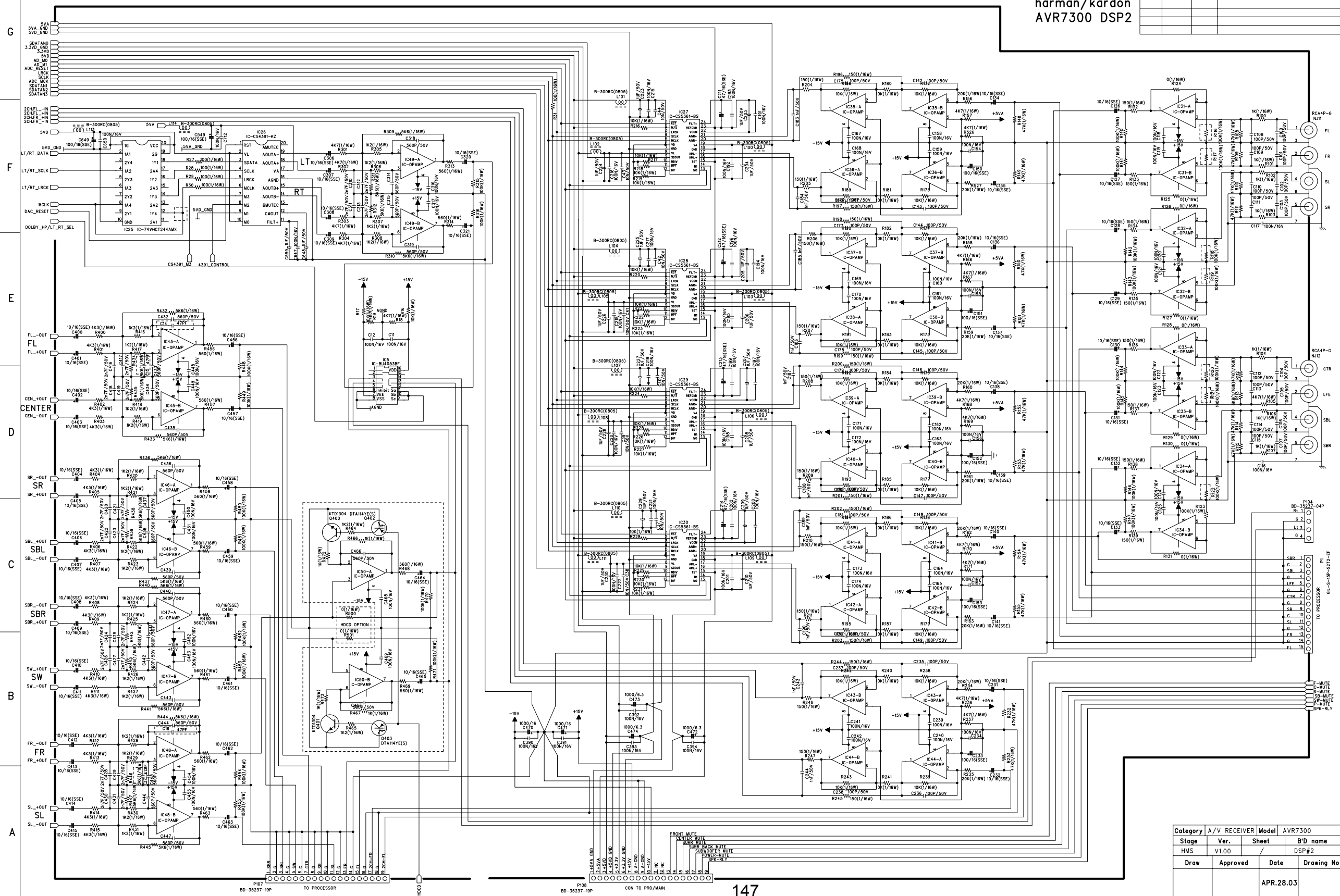

Category	A/V RECEIVER	Model	AVR7300
Stage	Ver.	Sheet	B'D name
HMS	V1.00		DSP#2
Draw	Approved	Date	Drawing No
		APR.28.03	

# SCHEMATIC DIAGRAM

harman/kardon  
AVR7300 CONNECTOR

REVISION RECORD			
LTR	ECO NO:	APPROVED:	DATE:

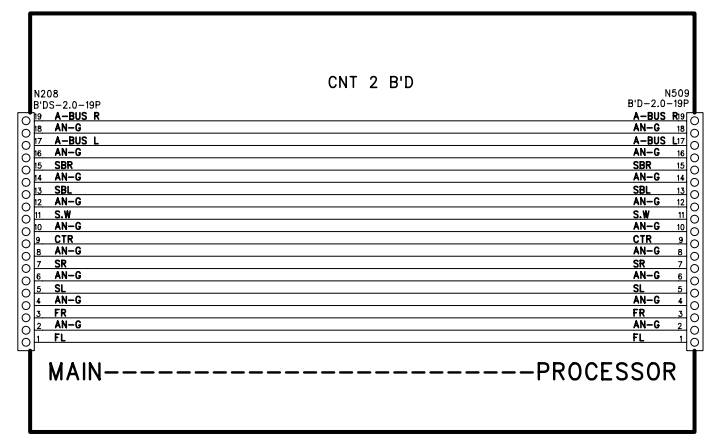
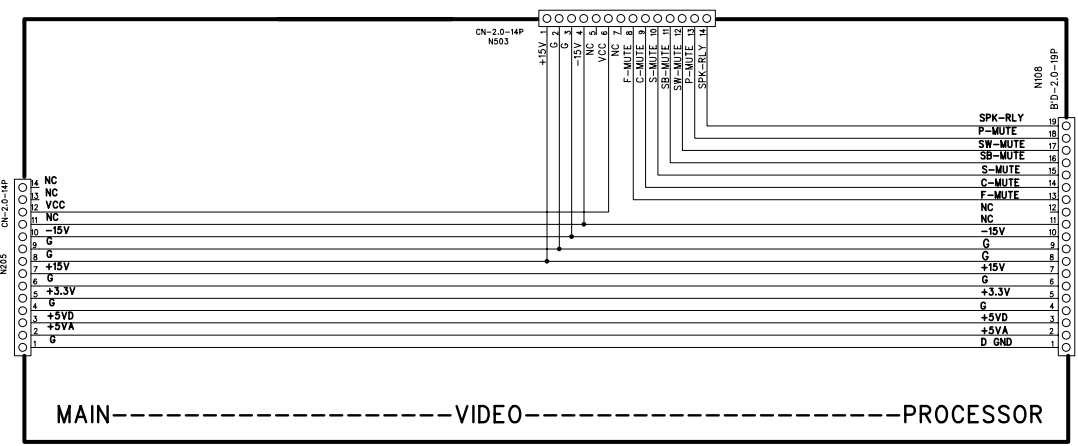
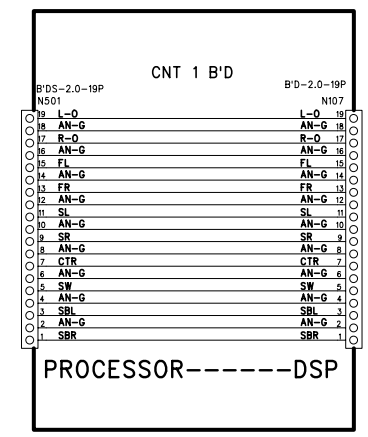
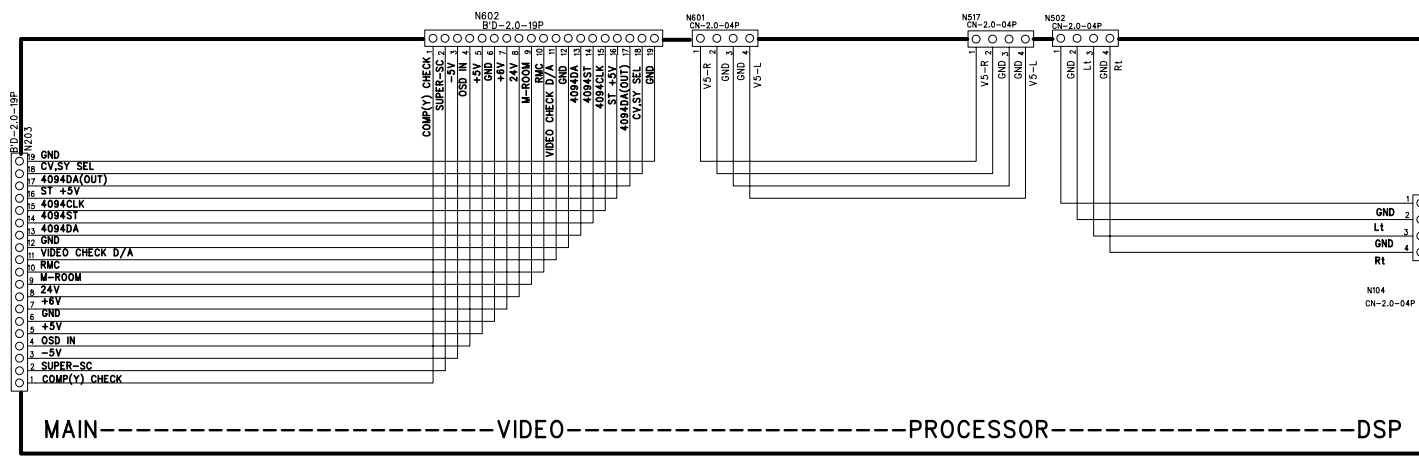

DRAWN:		DATED: JAN.03.2003		COMPANY: DANECH COMPANY			
CHECKED:		DATED:		TITLE: AVR7300 CONNECTOR			
QUALITY CONTROL:		DATED:		CODE:	SIZE:	DRAWING NO:	REV:
RELEASED:		DATED:		STAGE:FWS			TOTAL SHEET: 10 OF 11



REVISION RECORD		
NO.	Date	Contents

harman/kardon  
AVR7300 FRONT

# SCHEMATIC DIAGRAM

G  
F  
E  
D  
C  
B  
A

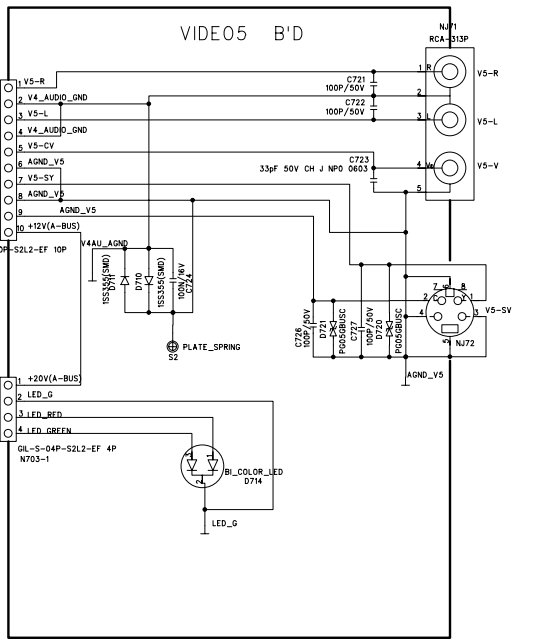
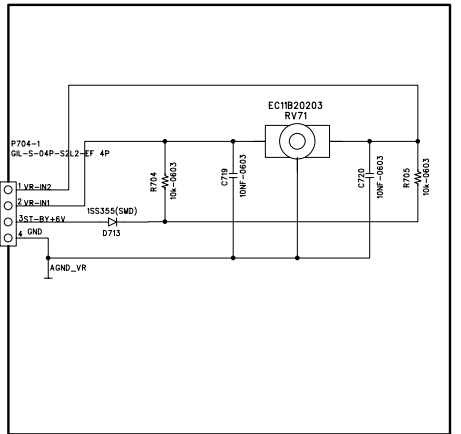
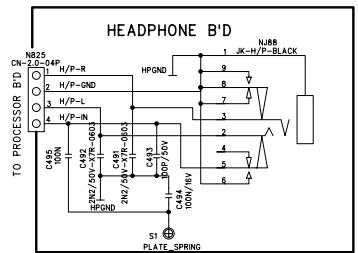
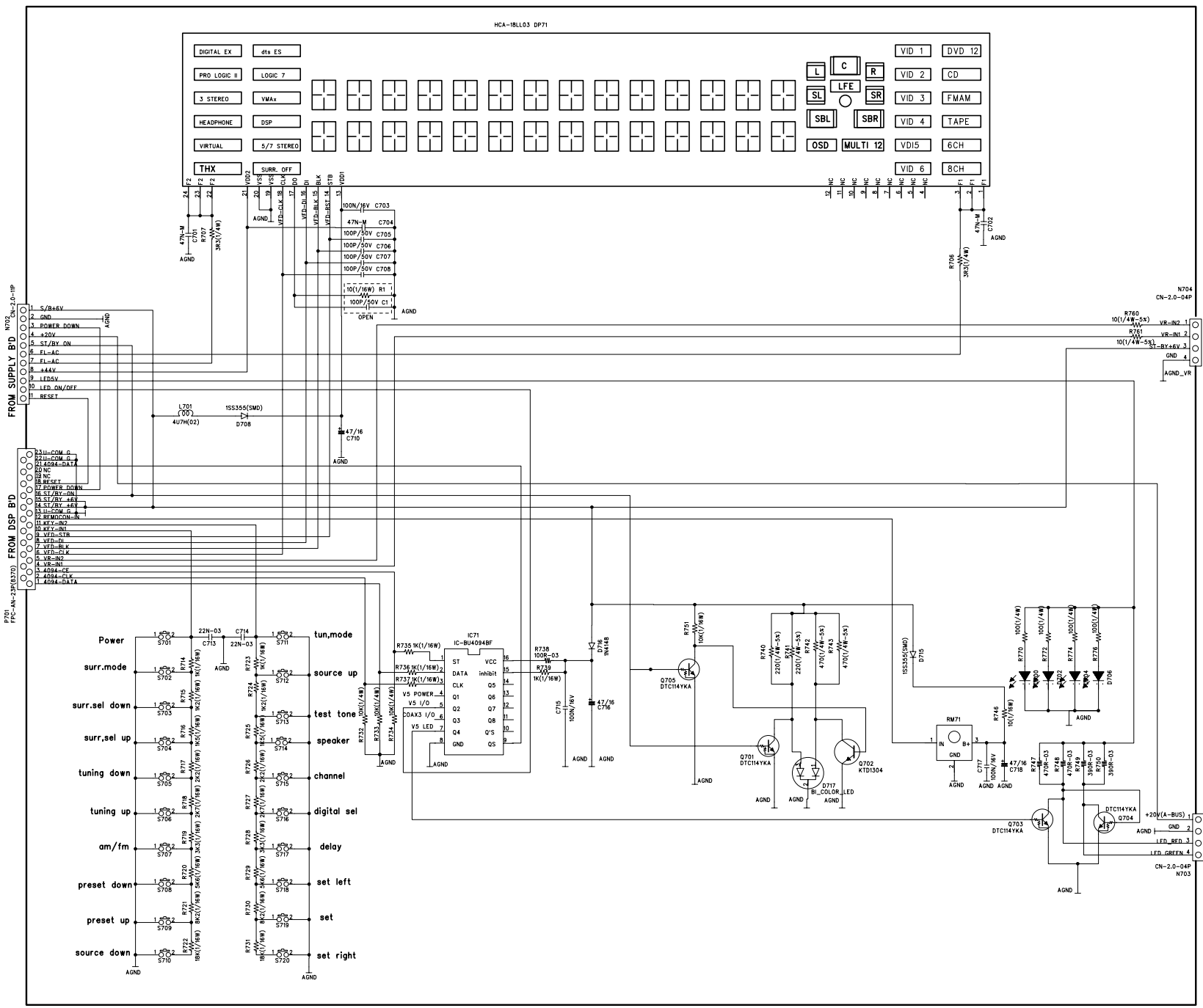

Category	Harman/Kardon	Model	AVR7300 Receiver
Stage	Ver.	Sheet	B'D name
TMS	v4.0		FRONT B'D
Draw	Approved	Date	Drawing No
		JAN.26.01	

# SCHEMATIC DIAGRAM

Harman/Kardon  
AVR7300 SUPPLY

REVISION RECORD		
NO.	Date	Contents

\*\*\* IMPORTANT SAFETY NOTICE. COMPONENTS IDENTIFIED BY  $\Delta$  MARK HAVE SPECIAL CHARACTERISTICS IMPORTANT FOR SAFETY. WHEN REPLACING ANY OF THESE COMPONENTS USE ONLY MANUFACTURER'S SPECIFIED PARTS.

\*\*\* THE UNIT OF RESISTANCE IS OHM.  
K=1000 OHM, M=1000 KOHM.

\*\*\* THE UNIT OF CAPACITANCE IS MICROFARAD ( $\mu$ F)  
pF=10<sup>-6</sup>  $\mu$ F

\*\*\* THIS SCHEMATIC DIAGRAM MAY MODIFIED AT ANYTIME WITH THE IMPROVEMENT OF PERFORMANCE.

F

E

D

C

B

A

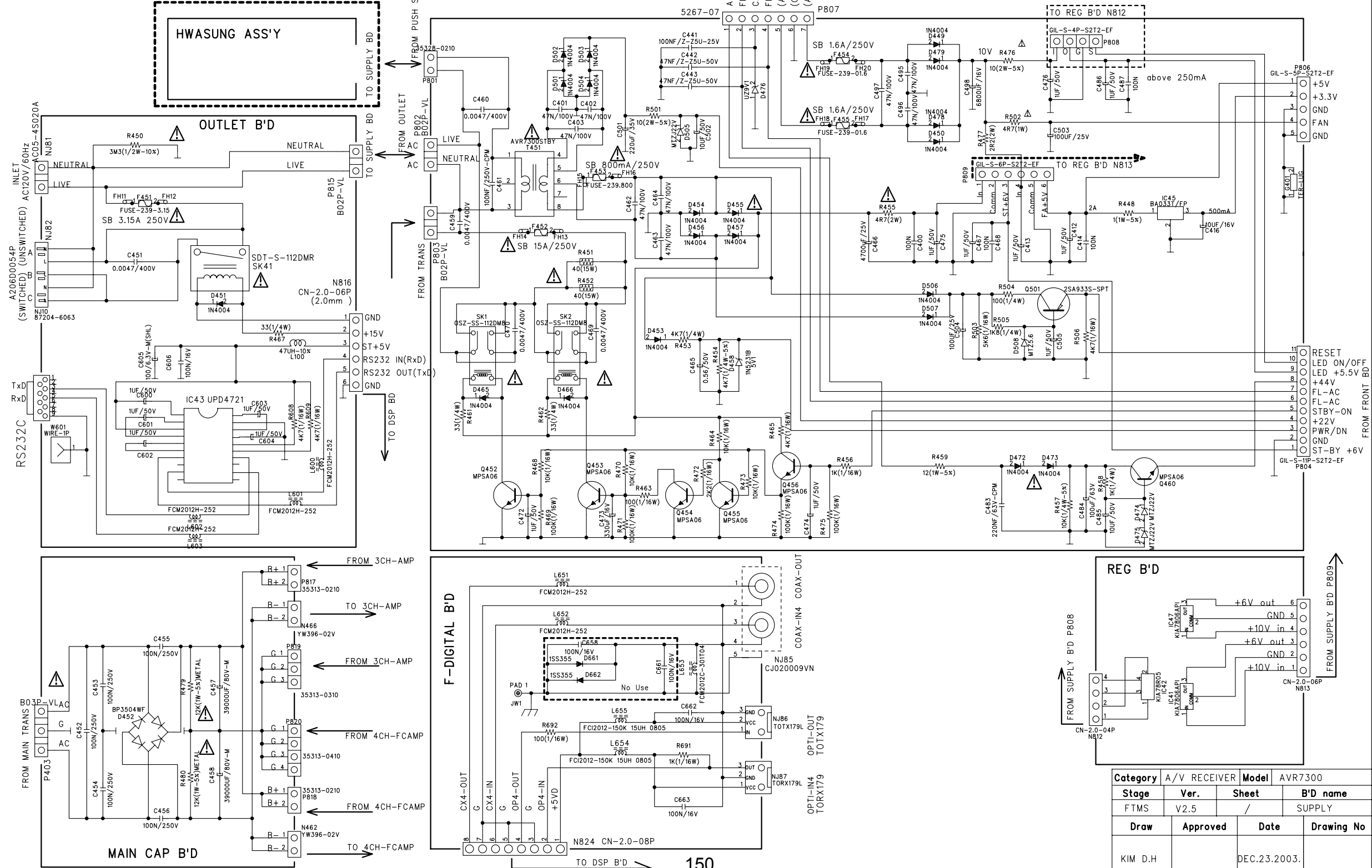

Category	A/V RECEIVER	Model	AVR7300
Stage	Ver.	Sheet	B'D name
FTMS	V2.5	/	SUPPLY
Draw	Approved	Date	Drawing No
KIM D.H		DEC.23.2003.	

# SCHEMATIC DIAGRAM harman/kardon AVR7300

REVISION RECORD		
No.	Date	Contents

## 3CH\_AMP B'D

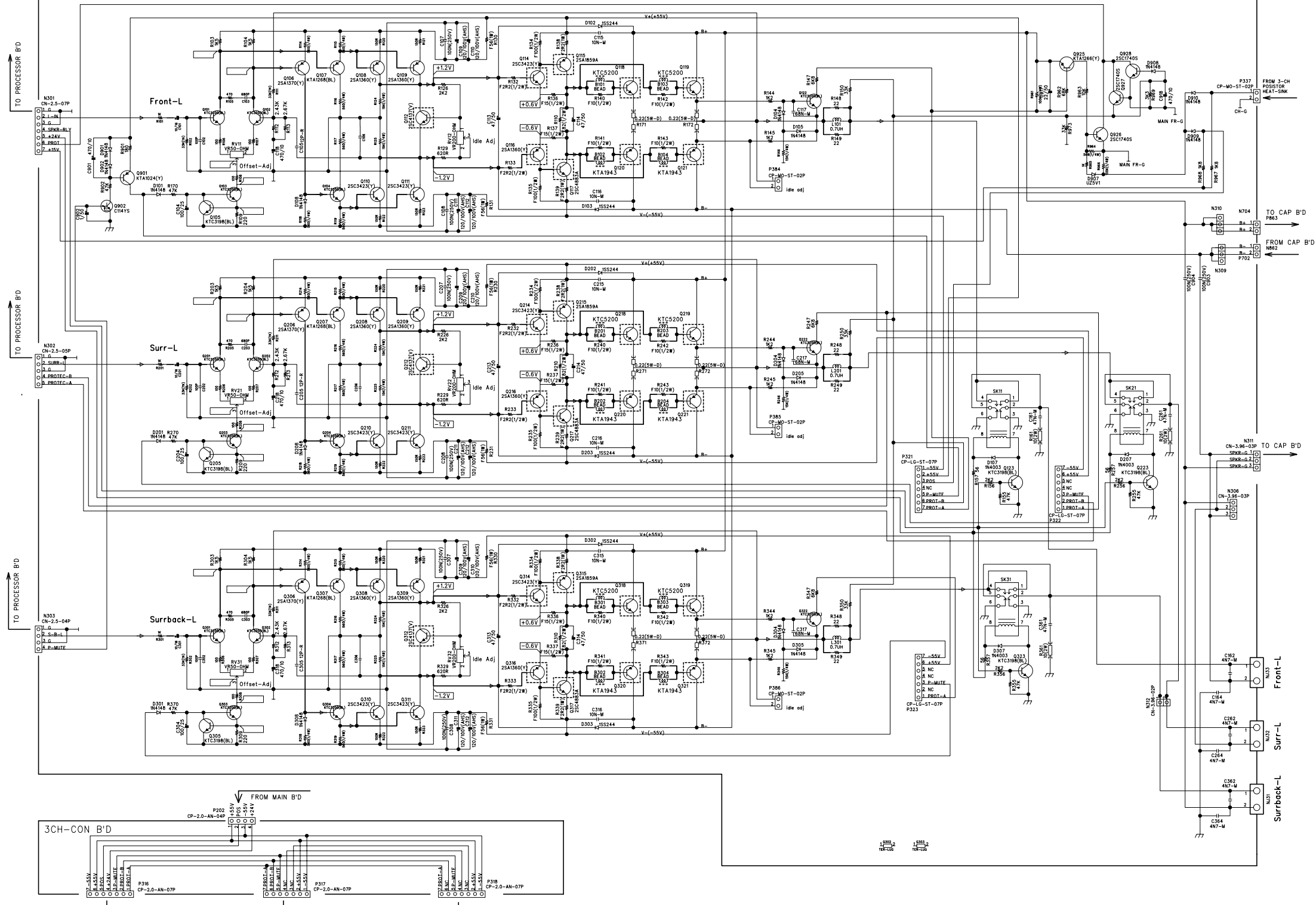

Category	AV RECEIVER	Model	AVR7300
Sheet	Ver.	Sheet	B/D name
FTMS	v2.101	/	3CHAMP
Draw	Approved	Date	Drawing No
KIM Y.G.		May.12.2003.	

# SCHEMATIC DIAGRAM harman/kardon AVR7300

REVISION RECORD	
No.	Date

4CH\_AMP B'D

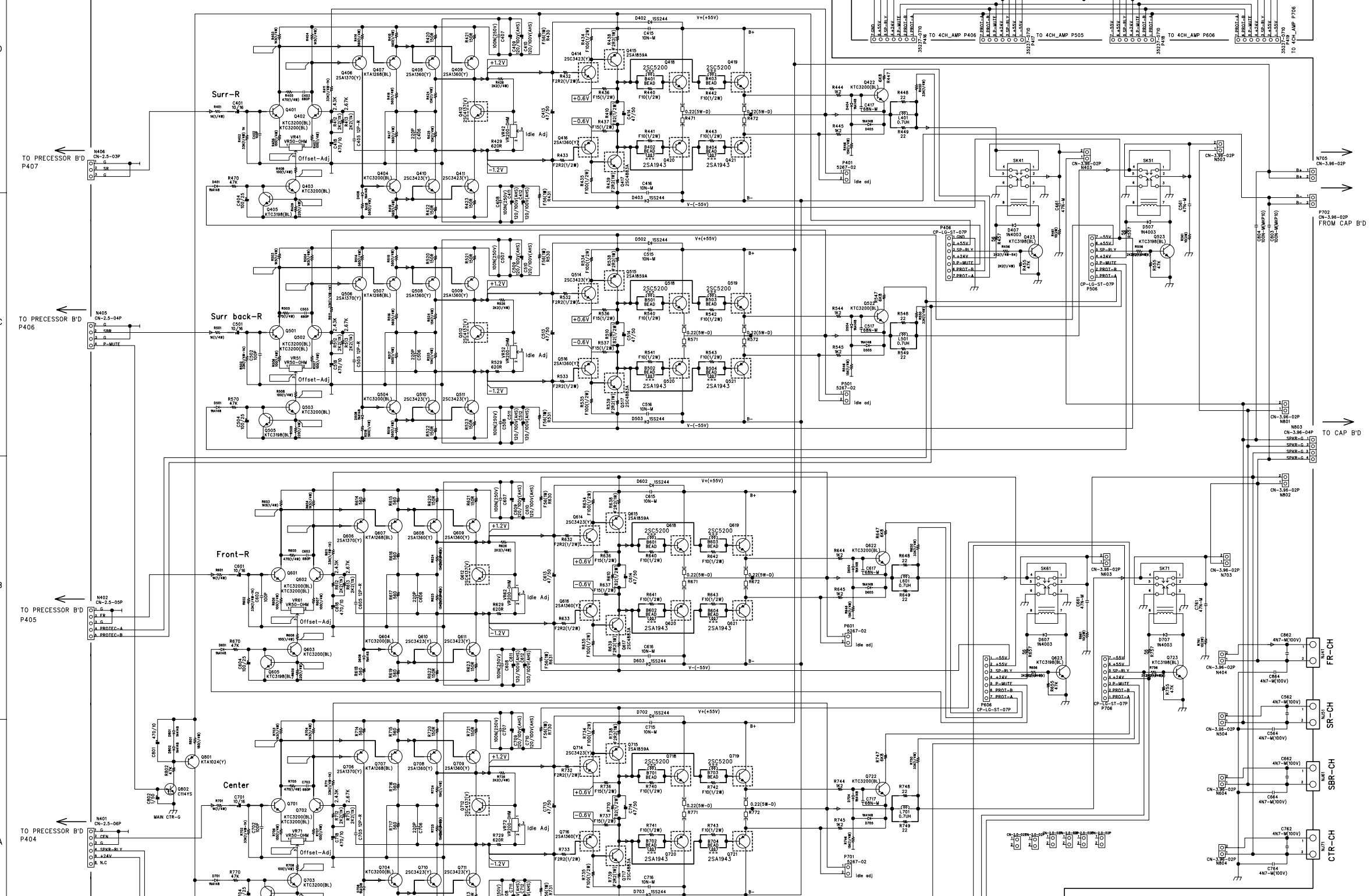

Category	AV RECEIVER	Model	AVR7300
Stage	Var.	Sheet	B'D name
HMS	v2.101		4CHAMP
Draw	Approved	Date	Drawing No
KIM Y.G.		SEP-12-2003.	

# SCHEMATIC DIAGRAM

harman/kardon  
AVR7300 VIDEO

REVISION RECORD		
NO.	Date	Contents

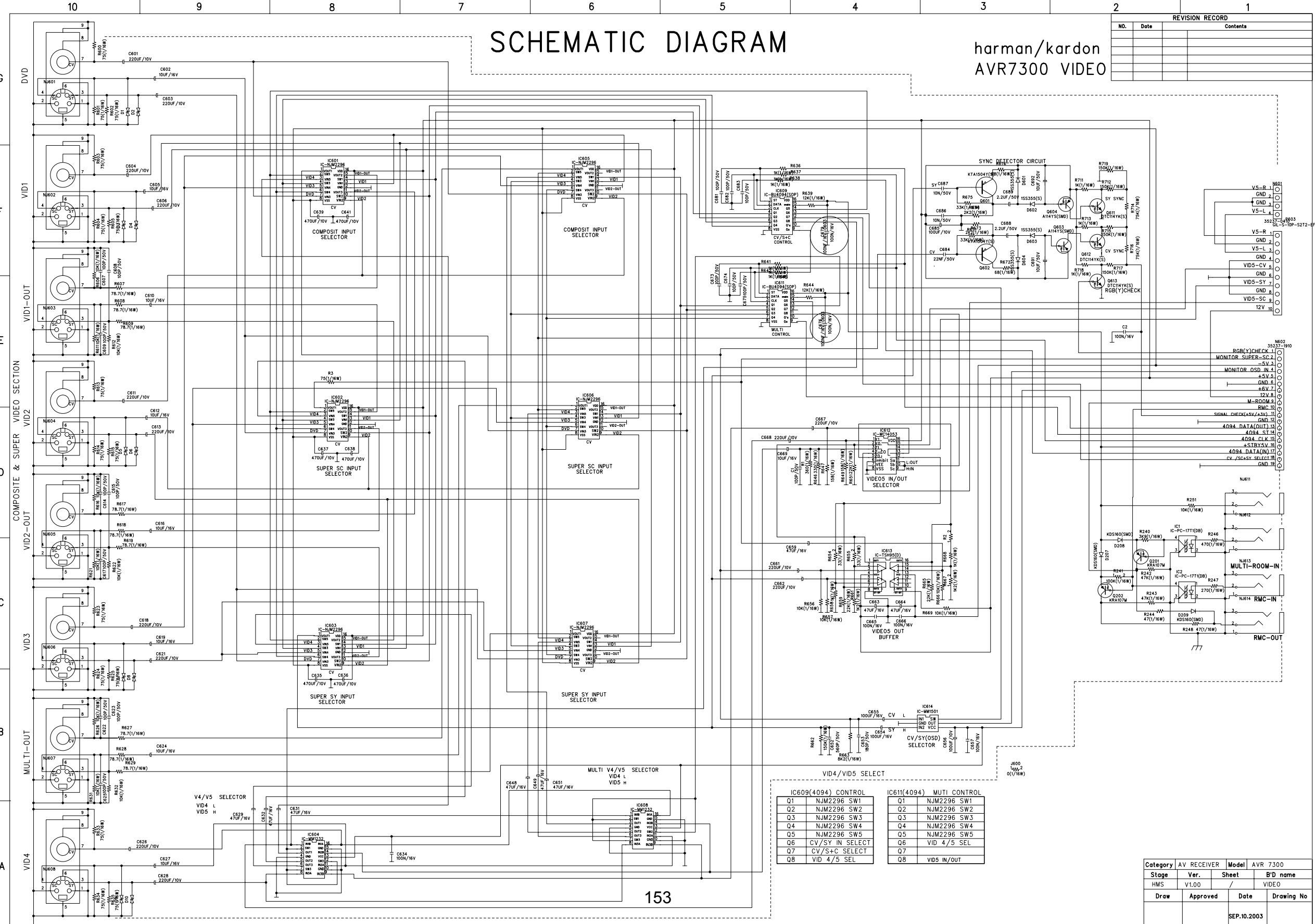

IC609(4094) CONTROL		IC611(4094) MULTI CONTROL	
Q1	NJM2296 SW1	Q1	NJM2296 SW1
Q2	NJM2296 SW2	Q2	NJM2296 SW2
Q3	NJM2296 SW3	Q3	NJM2296 SW3
Q4	NJM2296 SW4	Q4	NJM2296 SW4
Q5	NJM2296 SW5	Q5	NJM2296 SW5
Q6	CV/SY IN SELECT	Q6	VID 4/5 SEL
Q7	CV/S+C SELECT	Q7	
Q8	VID 4/5 SEL	Q8	VID5 IN/OUT

Category	AV RECEIVER	Model	AVR 7300
Stage	Ver.	Sheet	B'D name
HMS	V1.00	/	VIDEO
Draw	Approved	Date	Drawing No
		SEP.10.2003	



REVISION RECORD		
No.	Date	Contents

# AVR7300 harman/kardon

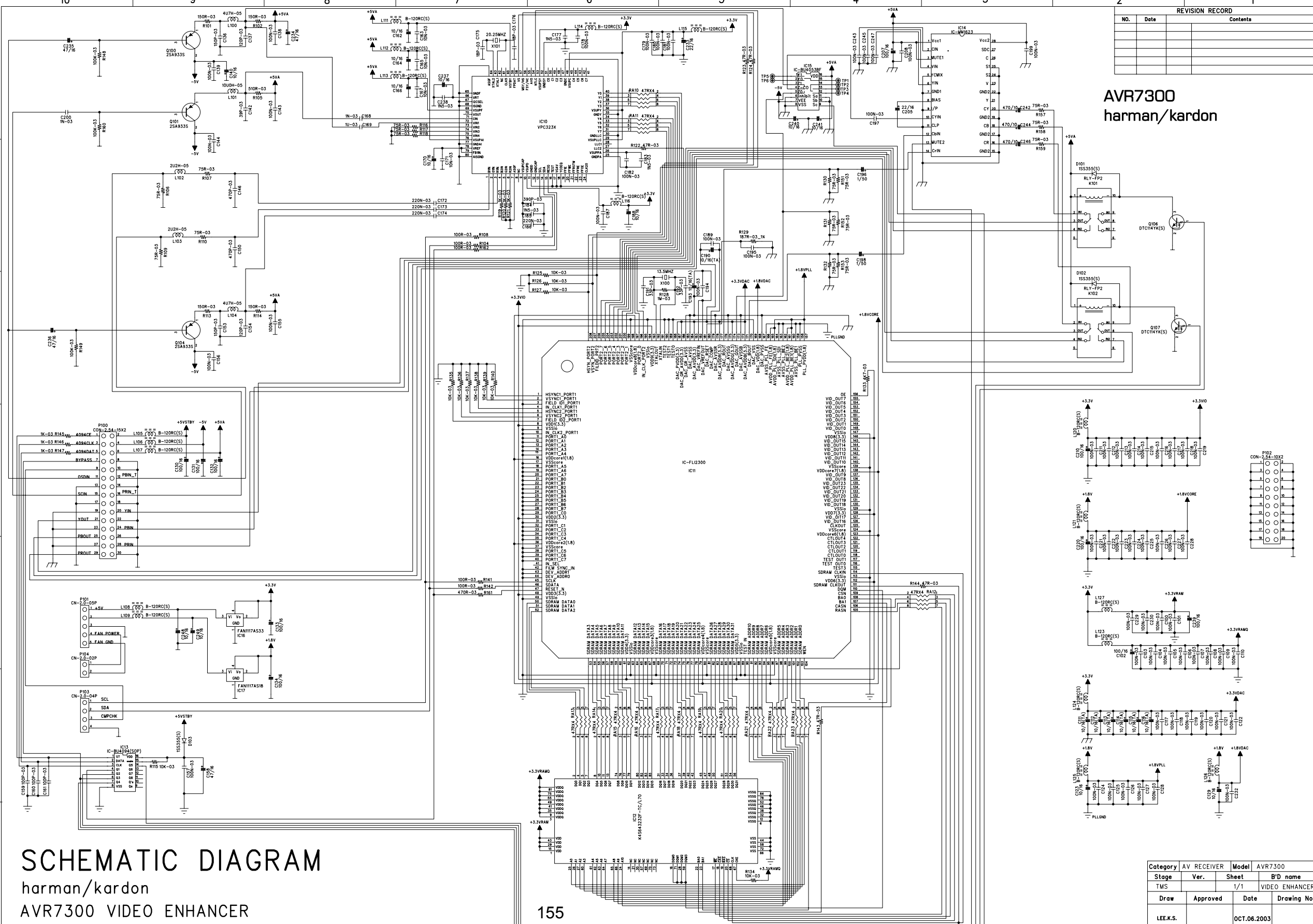

# SCHEMATIC DIAGRAM harman/kardon AVR7300 VIDEO ENHANCER

Category	AV RECEIVER	Model	AVR7300
Stage	Ver.	Sheet	B'D name
TMS		1/1	VIDEO ENHANCER
Draw	Approved	Date	Drawing No
LEE.K.S.		OCT.06.2003	

REVISION RECORD		
NO.	Date	Contents

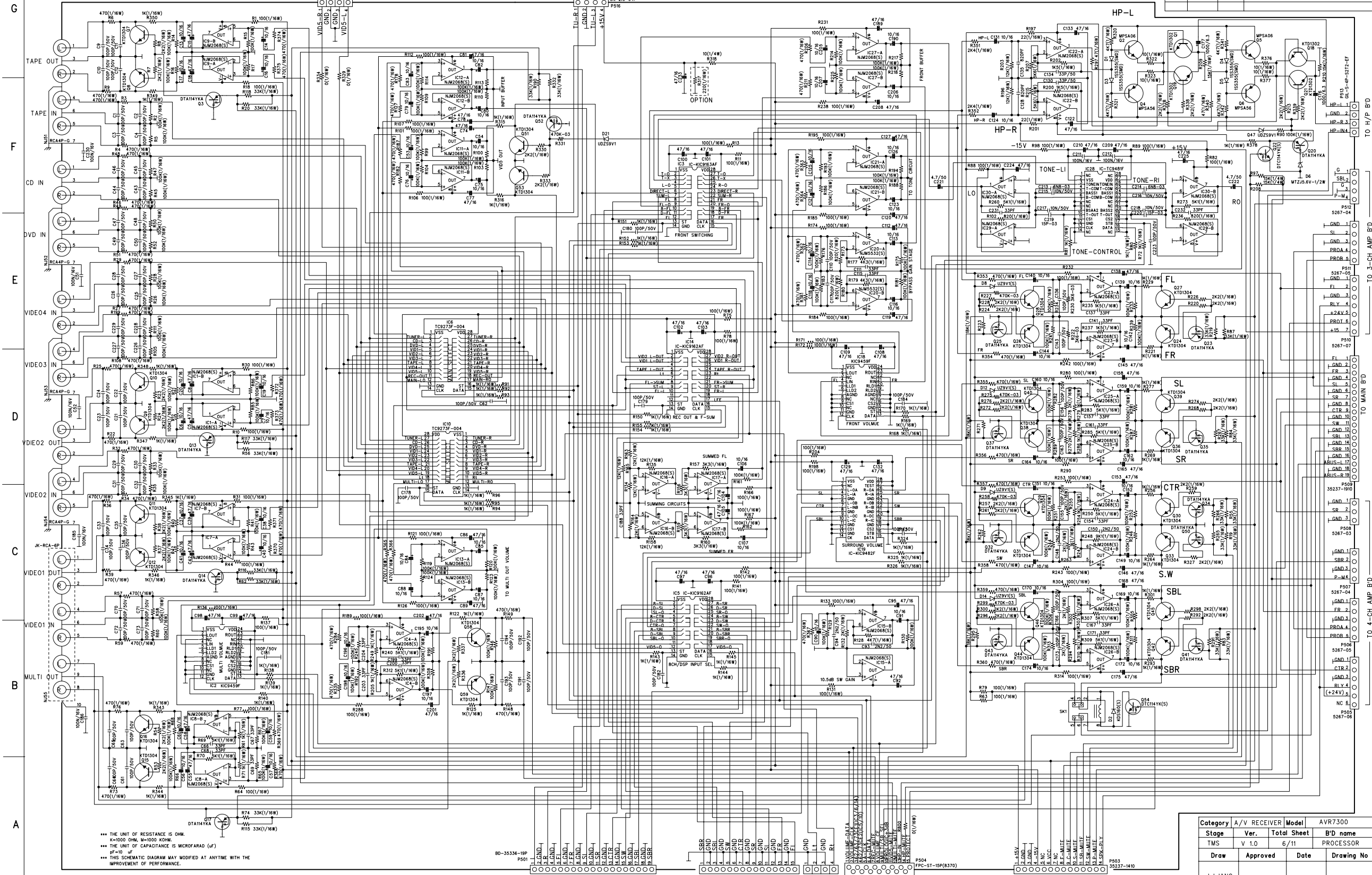

\*\* THE UNIT OF RESISTANCE IS OHM.  
 K=1000 OHM, M=1000 KOHM.  
 \*\* THE UNIT OF CAPACITANCE IS MICROFARAD ( $\mu$ F)  
 N=100 NANO FARAD  
 \*\*\* THIS SCHEMATIC DIAGRAM MAY MODIFIED AT ANYTIME WITH THE  
 IMPROVEMENT OF PERFORMANCE.

Category	A/V RECEIVER	Model	AVR7300
Stage	Ver. 1.0	Total Sheet	6/11
TMS	V 1.0	B'D name	PROCESSOR
Draw	Approved	Date	Drawing No
J.J.JANG		SEP.29.03	



# WIRING DIAGRAM

harman/kardon  
AVR7300 WIRING

REVISION RECORD		
No.	Date	Contents

AC IN AC120V/60Hz(UL)  
AC230V/50Hz(EUR)

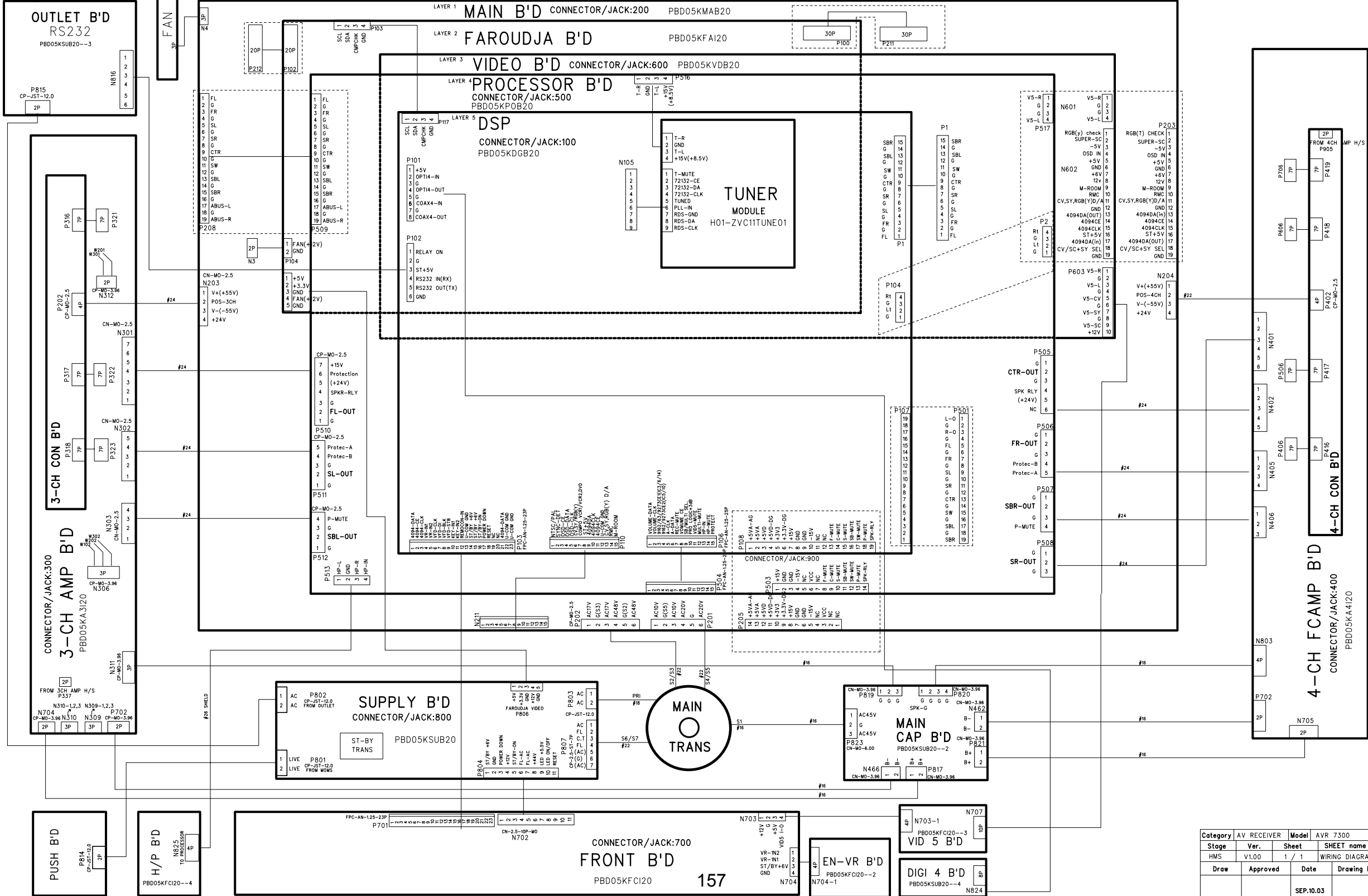

CONNECTOR/JACK:700  
FRONT B'D  
PBD05KFCI20

Category	AV RECEIVER	Model	AVR 7300
Stage	Ver.	Sheet	SHEET name
HMS	V1.00	1 / 1	WIRING DIAGRAM
Draw	Approved	Date	Drawing No
		SEP.10.03	

MRK	DATE	PNO	REVISION RECORD	DR.	MAK	DATE	PNO	REVISION RECORD	DR.
△					△				
△					△				
△					△				

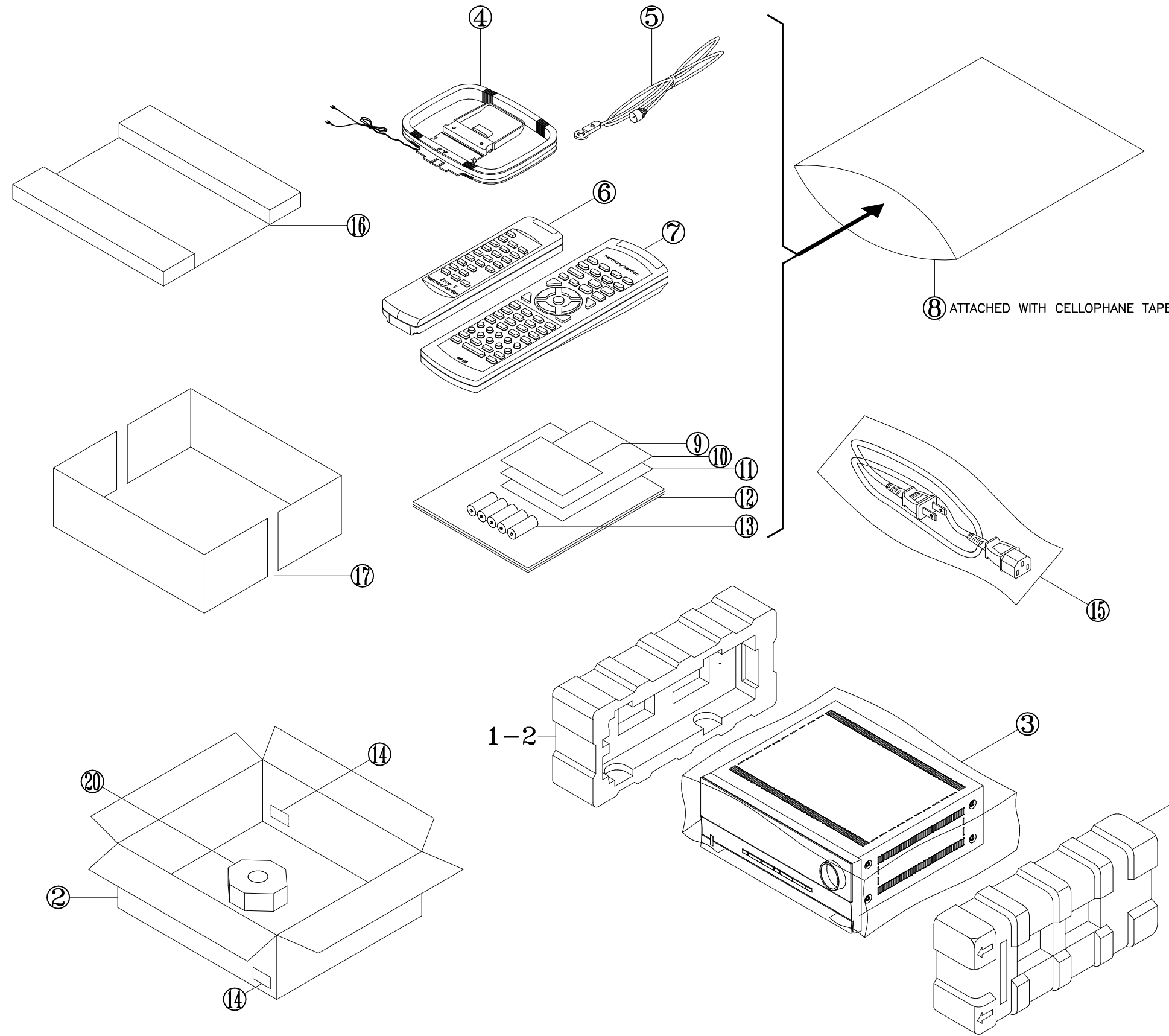

REF #	PART NUMBER	DESCRIPTION	QTY
1-1	ZQD0501HA00-9	CUSHION POLY EPS RIGHT AVR7300	1
1-2	ZQD0502HA00-5	CUSHION POLY EPS LEFT AVR7300	1
2	ZKD0504HA00-7	BOX CARTON AVR7300 (120v)	1
	ZKD1004HA00	BOX CARTON AVR7300 (230v)	
3	ZHD0501AAWH-2	FILM SHEET PE 1050X1050XT0.5	1
4	H01-ATALF039ABK-A	ANTENNA WIRE AM LOOP CT01-AM 0 0	1
	H01-WAB01200203-9	ANTENNA WIRE 75 CT02-FM 0 0 (120v)	
5	H01-WAD01200303	ANTENNA WIRE 75 CT02-FM 0 0 (230v)	1
6	H01-RYC1202HA00-5	REMOCON ZONE 2	1
7	H01-RYD0501HA00-0	REMOCON AVR7300 (120v)	1
	H01-RYD1001HA00	REMOCON AVR7300 (230v)	
8	ZBP00173851-2	BAG PE 170X380MMX0.17	1
9	ZKC1156HA00-A	CARD POST	1
10	ZKC1113HA00-9	CARD WARRANTY	1
11	ZKC1214HA00-A	LABEL SAFETY LEAFLET	1
12	ZKD0501HA00-8	OWNER'S MANUAL AVR7300 (120v)	1
	ZKD1001HA00	OWNER'S MANUAL AVR7300 (230v)	
13		BATTERY ALKALINE 1.5V AAA	6
14	ZKD0573HA00-9	LABEL BARCODE AVR7300 US	2
15	H01-WAUSA2103BK-1	POWER CORD WS SJT#14*2C L=2M	1
16	ZKD05H03A00-A	PAD ENDCAP PAD UPPER	1
17	ZKD05H04A00-7	PAD ENDCAP PAD INNER	2
18	ZKGEN56HA00-5	ENVELOPE POLISHING CLOTH	1
19	ZKC11H96A00-1	POLISHING CLOTH	1
20	ZQD0503HA00-1	CUSHION BOTTOM AVR7300	1

GENERAL TOLERANCE		±0.2 MM
DIVISION	GRADE	
1	2	3
4	5	6
7	8	9
10	11	12
13	14	15
16	17	18
19	20	21
22	23	24
25	26	27
28	29	30

NO.	PARTS NO.	PARTS NAME	DWG. NO.	MATERIAL	FINISH	QTY	MODEL NO.	MAKER
APPROVAL	CHECK	DRAWING	DESIGN	MODEL	SCALE	TOLERANCE	PARTS NAME	PARTS NO.
D.I.CHOI		J.H.KIM		N/S				
				UNIT			DWG. NO.	REV.
				m/m				